

INSTALLATION AND OPERATION MANUAL

**SURFACE
MOUNTED
TWO-POST
LIFTS**

**EXCEL
SERIES**

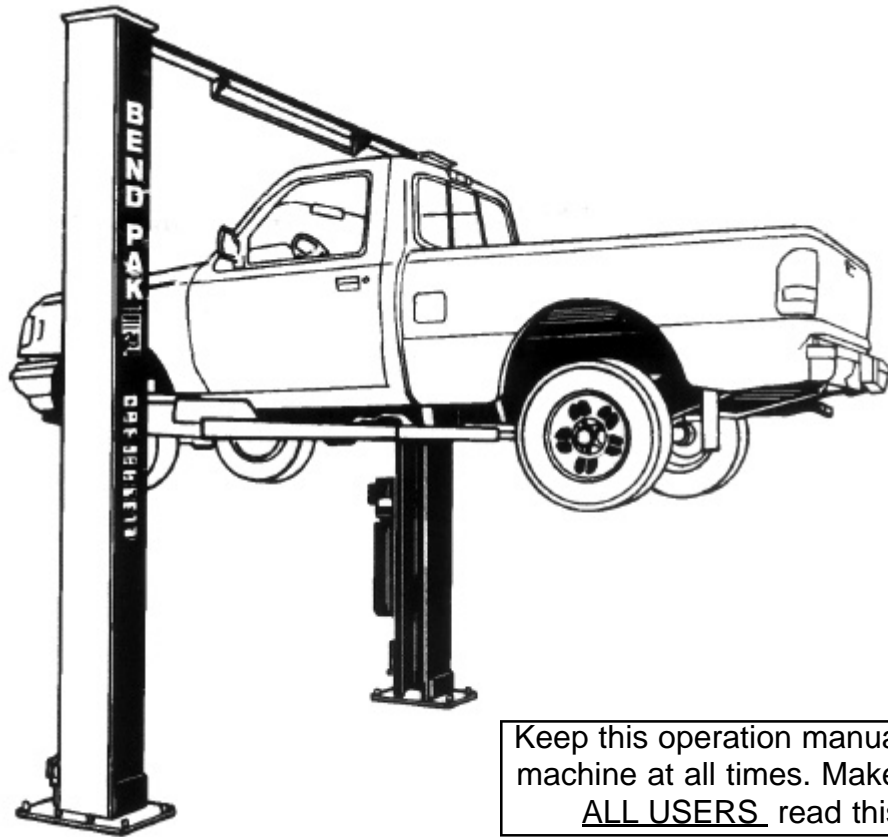

Keep this operation manual near the machine at all times. Make sure that ALL USERS read this manual.

SHIPPING DAMAGE CLAIMS

When this equipment is shipped, title passes to the purchaser upon receipt from the carrier. Consequently, claims for the material damaged in shipment must be made by the purchaser against the transportation company at the time shipment is received.

BE SAFE

Your new lift was designed and built with safety in mind. However, your overall safety can be increased by proper training and thoughtful operation on the part of the operator. **DO NOT** operate or repair this equipment without reading this manual and the important safety instructions shown inside.

TWO-POST SURFACE MOUNTED AUTO AND LIGHT DUTY TRUCK LIFT

This instruction manual has been prepared especially for you. Your new lift is the product of over 25 years of continuous research, testing and development and is the most technically advanced lift on the market today.

READ THIS ENTIRE MANUAL BEFORE OPERATION BEGINS.

RECORD HERE THE FOLLOWING INFORMATION
WHICH IS LOCATED ON THE SERIAL NUMBER DATA PLATE

Serial No. _____

Model No. _____

Manufacturing date _____

WARRANTY

Your new lift is warranted for five years on equipment structure; one year on all operating components to the original purchaser, to be free of defects in material and workmanship. The manufacturer shall repair or replace at their option for this period those parts returned to the factory freight prepaid which prove upon inspection to be defective.

The manufacturer will pay labor costs for the first 12 months only on parts returned as previously described.

This warranty does not extend to defects caused by ordinary wear, abuse, misuse, shipping damage, or lack of required maintenance.

This warranty is exclusive and in lieu of all other warranties expressed or implied. In no event shall the manufacturer be liable for special, consequential or incidental damages for the breach or delay in performance of the warranty. The manufacturer reserves the right to make design changes or add improvements to its product line without incurring any obligation to make such changes on product sold previously.

Warranty adjustments within the above stated policies are based on the model and serial number of the equipment. This data must be furnished with all warranty claims.

**WARRANTY IS NOT VALID UNLESS
WARRANTY CARD IS RETURNED**

PARTS INVENTORY

QTY. PART(S) DESCRIPTION **WHERE USED** **CHECK**

PARTS BOX

4	Lift Pads	Lift Pads For Arms
4	3" Lift Pad Adapters	Lift Pad Extensions
4	6" Lift Pad Adapters	Lift Pad Extensions
4	Arm Pins	Arm Pins
2	Cables	Equalizer Cables
10	3/4" x 4-3/4" Anchor Bolts	Concrete Anchors
1	Lot Shims	To Shim / Level Lift
1	Short Hose	From Power Unit To Cylinder
1	Long Hose	Crossover Hose
1	Micro switch With Cord / Clearfloor Only	Overhead Micro Switch
4	3/8" x 1" Hex Bolts	To Secure Top Beam
4	3/8" Hex Nuts	To Secure Top Beam
4	3/8" Lock washers	To Secure Top Beam
4	1/2"-13 Hex Nuts	Equalizer Cable Adjusting Nuts
4	5/16" x 1" Hex Bolts	For Mounting Power Unit
4	5/16" Hex Nuts	For Mounting Power Unit
1	90 Degree Fitting For Power Unit	Hydraulic Fitting For Power Unit
1	90 Degree Fitting For Cylinder	Hydraulic Fitting For Offside Cylinder
1	3-Port Hydraulic Fitting Assembly	Hydraulic Fitting For Powerside Cylinder
1	Can Spray Paint	Touch Up Paint
1	Instruction Manual	Instruction Manual
1	ALI Safety Instructions	Safety Instructions

SHIPMENT PARTS

1	Power Unit	Electric / Hydraulic Power Source
1	Powerside Column / With Mtg. Plate	Powerside Column
1	Offside Column / No Mtg. Plate	Offside Column
1	Top Trough / Clearfloor Models Only	Overhead Beam
1	Coverplate / Floorplate Models Only	Floor Pan
4	Lift Arms	Lift Arms

**BE SURE TO TAKE A COMPLETE INVENTORY
OF PARTS BEFORE STARTING INSTALLATION**

INTRODUCTION

1. Carefully remove the crating and packing materials. **CAUTION!** Be careful when cutting steel banding material as items may become loose and fall causing personal harm or injury.
2. Inspect the lift for any signs of concealed shipment damage or shortages. Remember to

- report any shipping damage to the carrier and make a notation on the delivery receipt.
3. Check the voltage, phase and proper amperage requirements for the motor shown on the motor plate. Wiring should be performed by a certified electrician only.

IMPORTANT SAFETY INSTRUCTIONS

Read these safety instructions entirely!

1. Read and understand all safety warning procedures before operating lift.
2. Keep hands and feet clear. Remove hands and feet from any moving parts. Keep feet clear of lift when lowering. Avoid pinch points.
3. Keep work area clean. Cluttered work areas invite injuries.
4. Consider work area environment. Do not expose equipment to rain. Do not use in damp or wet locations. Keep area well lighted.
5. Only trained operators should operate this lift. All non-trained personnel should be kept away from work area. Never let non-trained personnel come in contact with, or operate lift.
6. Use lift correctly. Use lift in the proper manner. Never use lifting adapters other than what is approved by the manufacturer.
7. Do not override self-closing lift controls.
8. Remain clear of lift when raising or lowering vehicle.
9. Clear area if vehicle is on danger of falling.
10. Always insure that the safeties are engaged before any attempt is made to work on or near vehicle.
11. Dress properly. Non-skid steel-toe footwear is recommended when operating lift.
12. Guard against electric shock. This lift must be grounded while in use to protect the operator

from electric shock. Never connect the green power cord wire to a live terminal. This is for ground only.

13. Danger! The power unit used on this lift contains high voltage. Disconnect power at the receptacle before performing any electrical repairs. Secure plug so that it cannot be accidentally plugged in during service.

14. Warning! Risk of explosion. This equipment has internal arcing or sparking parts which should not be exposed to flammable vapors. This machine should not be located in a recessed area or below floor level.

15. Maintain with care. Keep lift clean for better and safe performance. Follow manual for proper lubrication and maintenance instructions. Keep control handles and/or buttons dry, clean and free from grease and oil.

16. Stay alert. Watch what you are doing. Use common sense. Be aware.

17. Check for damaged parts. Check for alignment of moving parts, breakage of parts or any condition that may affect its operation. Do not use lift if any component is broken or damaged.

18. Never remove safety related components from the lift. Do not use lift if safety related components are damaged or missing.



THIS SYMBOL POINTS OUT IMPORTANT SAFETY INSTRUCTIONS WHICH IF NOT FOLLOWED COULD ENDANGER THE PERSONAL SAFETY AND/OR PROPERTY OF YOURSELF AND OTHERS AND CAN CAUSE PERSONAL INJURY OR DEATH. READ AND FOLLOW ALL INSTRUCTIONS IN THIS MANUAL BEFORE ATTEMPTING TO OPERATE THIS MACHINE.

TOOLS REQUIRED

- " Rotary Hammer Drill Or Similar
- " 3/4" Masonry Bit
- " Hammer
- " 4 Foot Level
- " Open-End Wrench Set: 7/16" - 1-1/8"
- " Socket And Ratchet Set: 7/16" - 1-1/8"
- " Hex-Key / Allen Wrench Set
- " Medium Crescent Wrench
- " Medium Pipe Wrench
- " Crow Bar For Shim Installation
- " Chalk Line
- " Medium Flat Screwdriver
- " Tape Measure: 25 Foot Minimum
- " Needle Nose Pliers

IMPORTANT NOTICE

These instructions must be followed to insure proper installation and operation of your lift. Failure to comply with these instructions can result in serious bodily harm and void product warranty. Manufacturer will assume no liability for loss or damage of any kind, expressed or implied resulting from improper installation or use of this product.

PLEASE READ ENTIRE MANUAL PRIOR TO INSTALLATION.

STEP ONE

(Selecting Site)

Before installing your new lift, check the following.

1. **LIFT LOCATION:** Always use architects plans when available. Check layout dimension against floorplan requirements making sure that adequate space is available.
2. **OVERHEAD OBSTRUCTIONS:** The area where the lift will be located should be free of overhead obstructions such as heaters, building supports, electrical lines etc.
3. **DEFECTIVE CONCRETE:** Visually inspect the site where the lift is to be installed and check for cracked or defective concrete.

STEP TWO

(Floor Requirements)



Specifications of concrete must be adhered to. Failure to do so could cause lift failure resulting in personal injury or death.

A level floor is suggested for proper installation. Small differences in floor slopes may be compensated for by proper shimming.

If a floor is of questionable slope, consider a survey of the site and/or the possibility of pouring a new level concrete slab.

- " DO NOT install this lift on any asphalt surface or any surface other than concrete.
- " DO NOT install this lift on expansion seams or on cracked or defective concrete.
- " DO NOT install this lift on a second / elevated floor without first consulting building architect.
- " DO NOT install this lift outdoors unless special consideration has been made to protect the power unit from inclement weather conditions.

CONCRETE SPECIFICATIONS

LIFT MODEL	CONCRETE REQUIREMENT
9,000 Lb. Models	4" Min. Thickness / 3000 PSI
12,000 Lb. Model	6" Min. Thickness / 3000 PSI

NOTE

All models **MUST** be installed on 3000 PSI concrete only conforming to the minimum requirements shown above. New concrete must be adequately cured by at least 28 days minimum.

FLOORPLAN LAYOUT

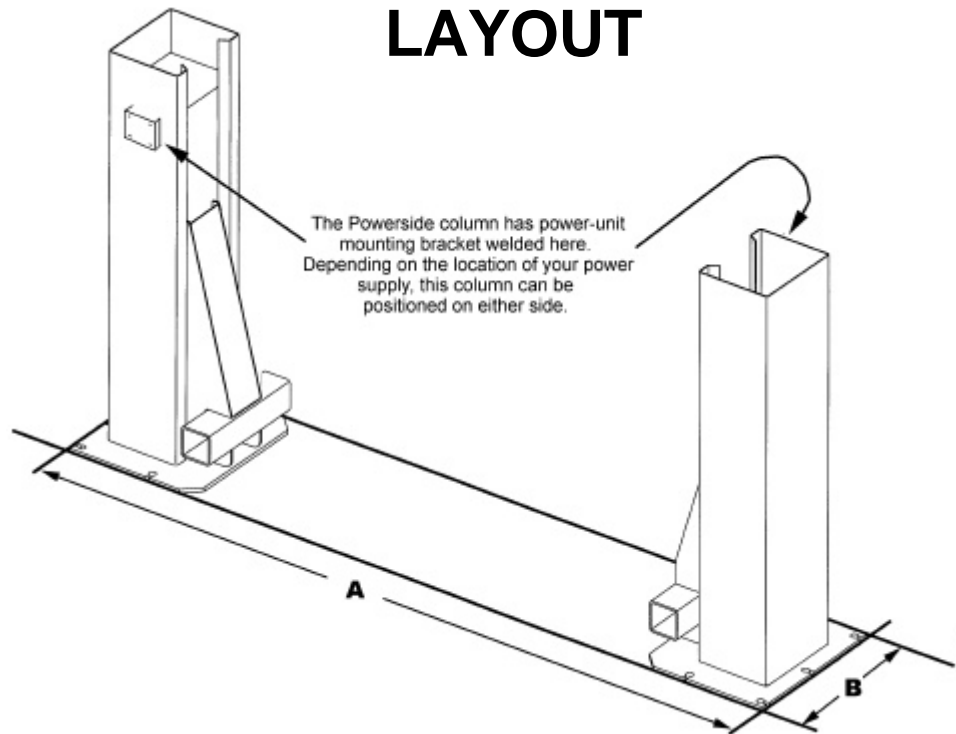

LAYOUT DIMENSIONS

MODEL	A	B
XL-9	132" / 3353mm	17" / 432mm
XL-9X	145" / 3683mm	17" / 432mm
XL-9C	132" / 3353mm	17" / 432mm
XL-9CX	145" / 3683mm	17" / 432mm
XL-9AC	132" / 3353mm	17" / 432mm
XL-9ACX	145" / 3683mm	17" / 432mm
PR-12F	155" / 3937mm	28" / 711mm

STEP THREE

(Site Layout)

1. Determine which side will be the approach side.
2. Now determine which side you prefer the power unit to be located on. The POWERSIDE column has the power-unit mounting bracket attached to the side. (See diagram above for power unit location.)
3. Once a location is determined, use a carpenters chalk line to layout a grid for the post locations. Keep all dimensions and squareness within 1/8" or malfunctioning of the lift will occur.
4. After the post locations are properly marked, use a chalk or crayon to make an outline of the posts on the floor at each location using the post baseplates as a template.
5. Double check all dimensions and make sure that the layout is perfectly square.
6. Before continuing with the installation it is helpful to stand the posts up at their respective locations and get a visual of the shop, aisles and other clearances. Also, this is a good time to drive a vehicle into position and check for adequate clearance.

STEP FOUR

(Installing The POWERSIDE Column)

1. Before proceeding, double check measurements and make certain that the bases of each column are square and aligned with the chalk line.

2. Using the baseplate on the POWERSIDE column as a guide, drill each anchor hole in the concrete approximately (4-1/2" deep / 9K models & 6-1/2" deep / 12K models) using a rotary hammer drill and 3/4" concrete drill. To assure full holding power, do not ream the hole or allow drill to wobble. (See Fig. 1)

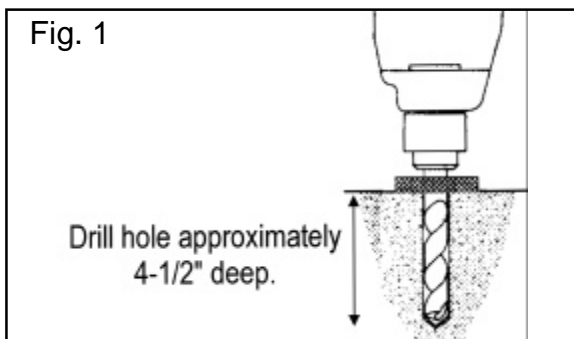

5. After drilling, remove dust thoroughly from each hole using compressed air and/or wire brush. Make certain that the column remains aligned with the chalk line during this process.

6. Assemble the washers and nuts on the anchors then tap into each hole with a hammer until the washer rests against the baseplate. Be sure that if shimming is required that enough threads are left exposed. (See Fig. 2)

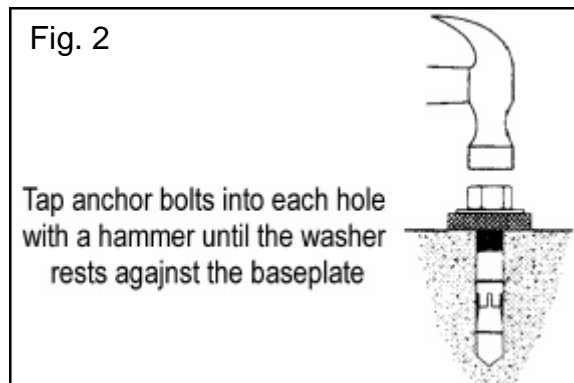

7. If shimming is required, insert the shims as necessary under the baseplate so that when the anchor bolts are tightened, the columns will be plumb. (See Fig. 3)

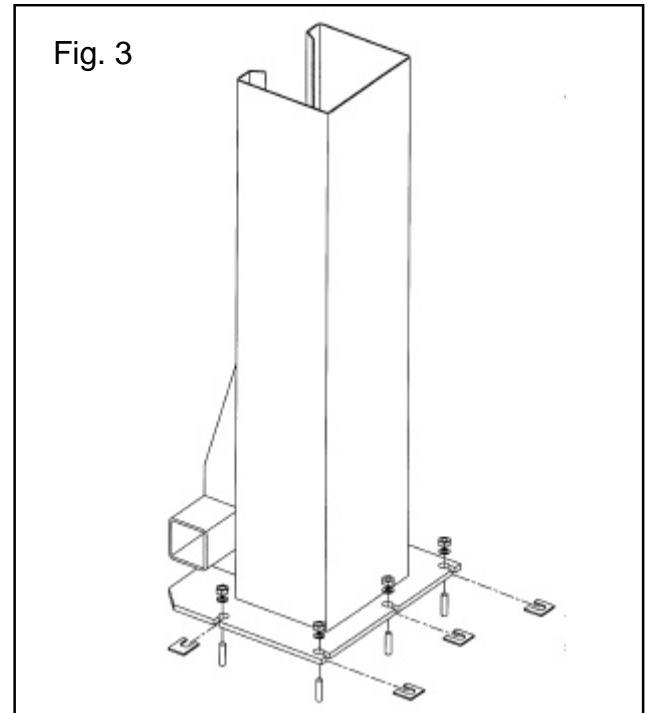

8. With the shims and anchor bolts in place, tighten by securing the nut to the base then turning 2 -3 full turns clockwise. DO NOT use an impact wrench for this procedure. (See Fig. 4)

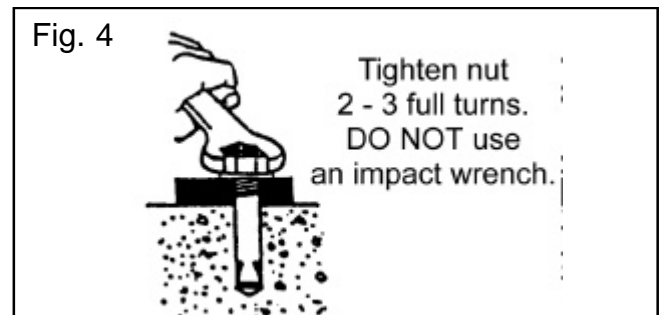

STEP FIVE

(Mounting The OFFSIDE column.)

1. Position the OFFSIDE column at the designated chalk locations and secure to the floor following the same procedures as outlined in STEP FIVE.

NOTE:

To ease installation of the top beam on CLEARFLOOR models, it helps to keep the anchor bolts loose on one of the columns until the top beam is mounted.

STEP SIX

(Mounting the OVERHEAD BEAM.)
Clearfloor Models Only

1. Using a lifting devise, raise the OVERHEAD beam in position on top of the columns. Bolt to the columns using the 3/8" x 1" Hex Bolts, Nuts and Washers. (See Fig. 5)

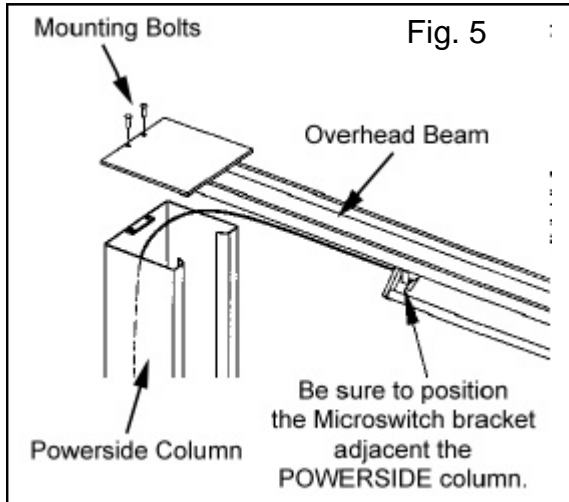

STEP SEVEN

(Mounting the TOP PULLEY ASSEMBLY.)
Floorplate Models Only

1. Using a lifting devise, raise the OVERHEAD beam in position on top of the columns. Bolt to the columns using the 3/8" x 1" Hex Bolts, Nuts and Washers. (See Fig. 6)

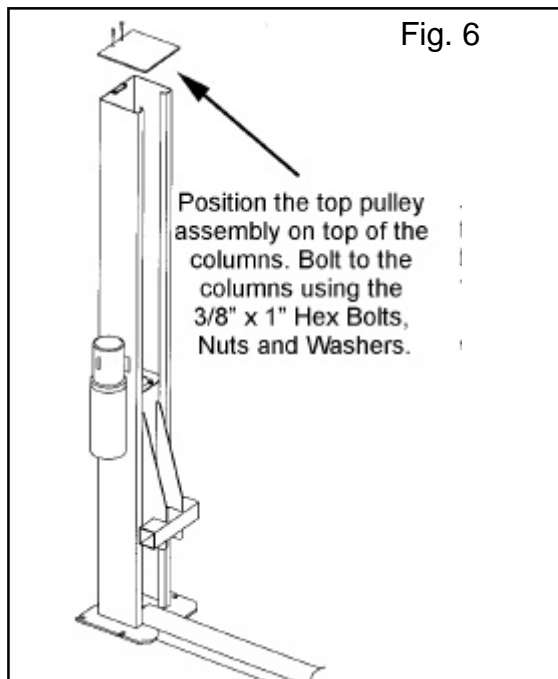

STEP EIGHT

(Mounting The POWER UNIT)

1. Attach the power unit to the POWERSIDE COLUMN using four 5/16" hex bolts and nylock nuts supplied. **Fill the reservoir with 10 WT. HYDRAULIC OIL OR DEXRON TYPE III ATF.** Make sure the funnel used to fill the power unit is clean. (See Fig. 7)

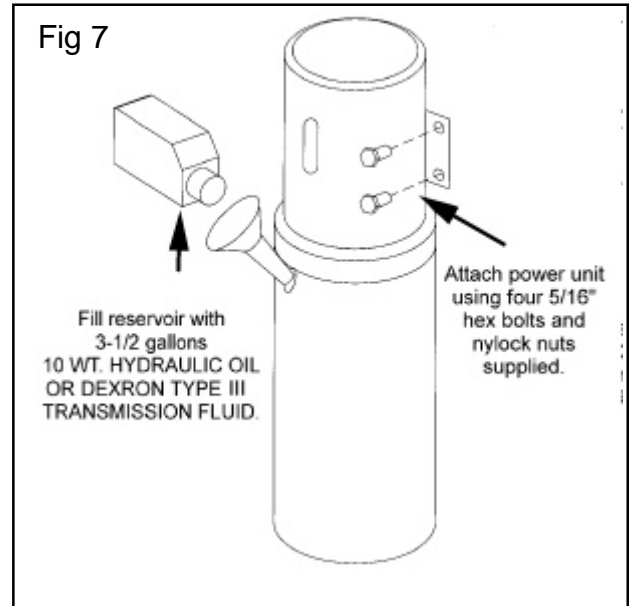

STEP NINE

(Routing The EQUALIZER CABLES)

1. Raise and lock each carriage approximately 28" above the ground. (See Fig. 8)

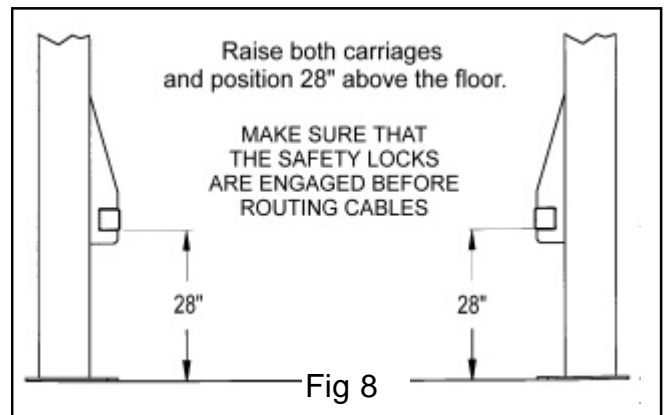

2. Make sure that the safety locks on each column are fully engaged before attempting to route equalizer cables. Carriages must be equal height from the floor before proceeding.

3. With the carriages in equal position from the floor, route the equalizer cables as shown below. (See Fig. 9 & 10)

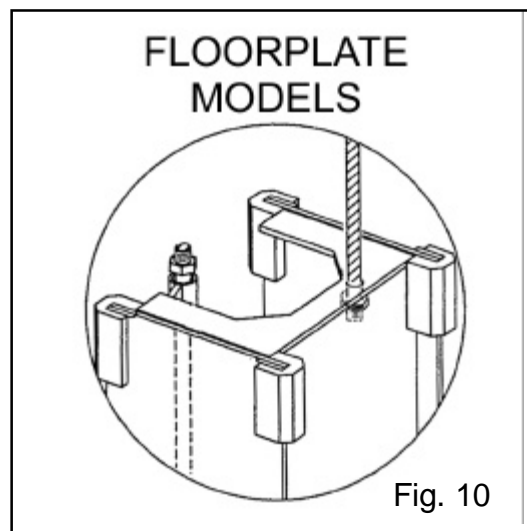
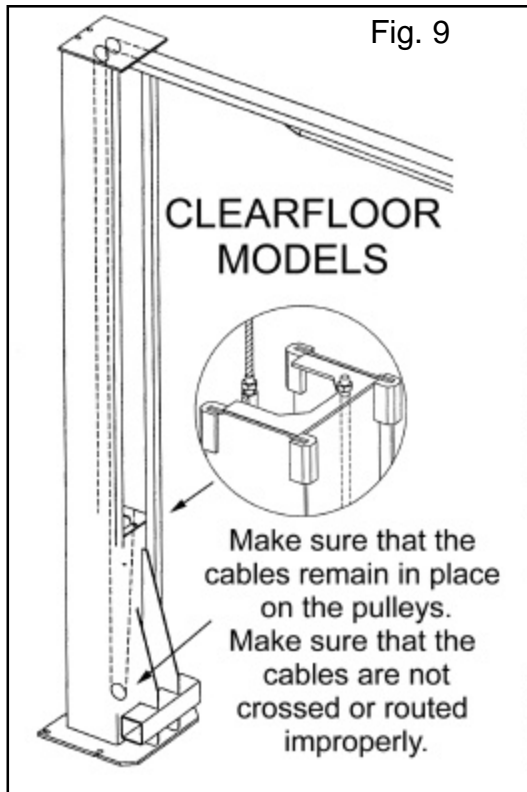

4. After the equalizer cables have been routed, adjust each cable so that they are equal tension.

IMPORTANT NOTE:
The equalizer cables should be checked weekly for equal tension. Failure to do this will cause uneven lifting. The cables should always be adjusted so that they are equal tension when resting on the safety locks.

STEP TEN

(Installing The Hydraulic Lines.)

1. Install the hydraulic lines as shown below paying careful attention to keep the hoses clean and free of debris. (See Fig. 11 & 12)



When routing the hydraulic hose through the columns, make sure to route through the retaining rings welded inside each column. Make sure that the hose is clear of any moving parts. It may be necessary to tie hose clear by using nylon tie straps or wire. Failure to keep hydraulic lines clear may result in hydraulic line failure which may result in damage or personal harm.

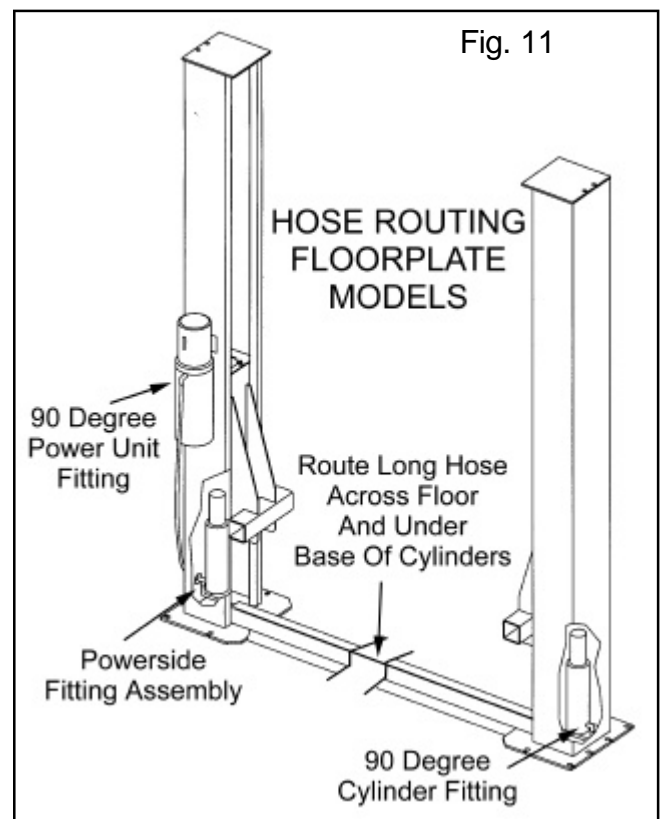

IMPORTANT NOTE:
When installing hydraulic fittings and hoses it is not necessary to use Teflon tape or other sealant. Teflon tape and other sealing compounds can contaminate the system and cause malfunctioning of lift.

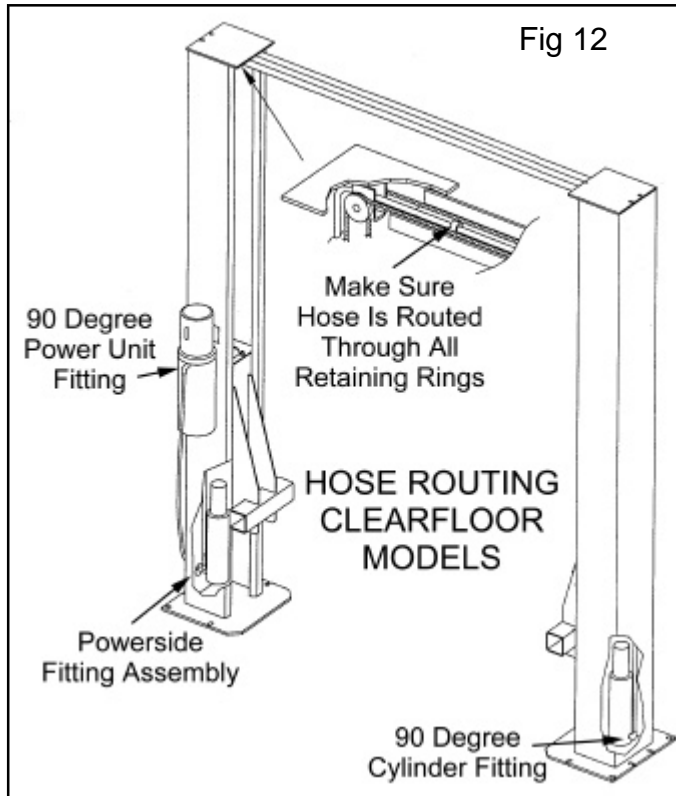

STEP ELEVEN

(Installing Overhead Micro Switch.)

1. Install the overhead Micro Switch as shown below. Be sure to keep wire clear of moving parts. WIRING MUST BE PERFORMED BY A CERTIFIED ELECTRICIAN. (See Fig. 13)

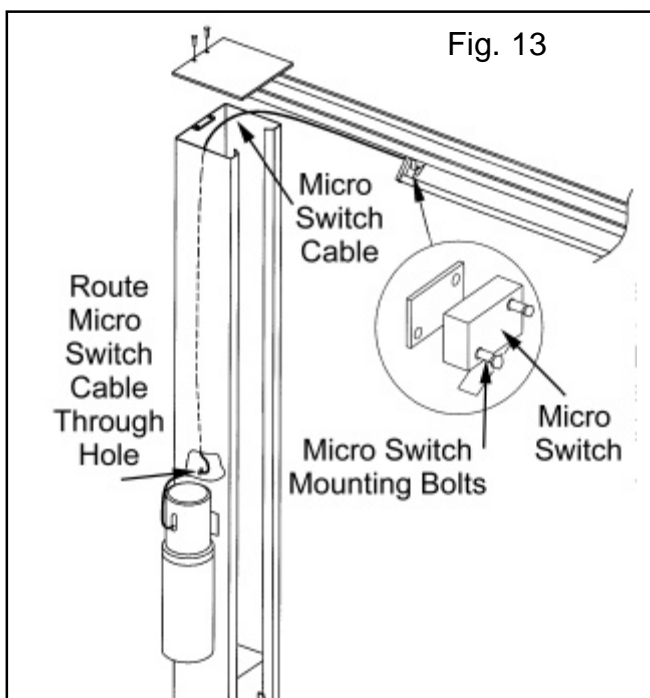

STEP TWELVE

(Power Unit Installation.)

1. The standard power unit for your lift is 220 volt, 60HZ, single phase. All wiring must be performed by a certified electrician only. SEE WIRING INSTRUCTIONS AFFIXED TO MOTOR FOR PROPER WIRING INSTRUCTIONS

IMPORTANT INSTALLATION NOTES

- " DO NOT run power unit with no oil. Damage to pump can occur.
- " The power unit must be kept dry. Damage to power unit caused by water or other liquids such as detergents, acid etc., is not covered under warranty.
- " Improper electrical hook-up can damage motor and will not be covered under warranty
- " Motor can not run on 50HZ without a physical change in motor.
- " Use a separate breaker for each power unit.
- " Protect each circuit with time delay fuse or circuit breaker.
- " For 208-230 volt, single phase, use a 25 amp fuse.
- " For 208-230 volt, three phase, use a 20 amp fuse.
- " For 380-440 volt, three phase, use a 15 amp fuse.

WARNING

RISK OF EXPLOSION!! This equipment has internal arcing or sparking parts which should not be exposed to flammable vapors. Motor should not be located in a recessed area or below floor level.

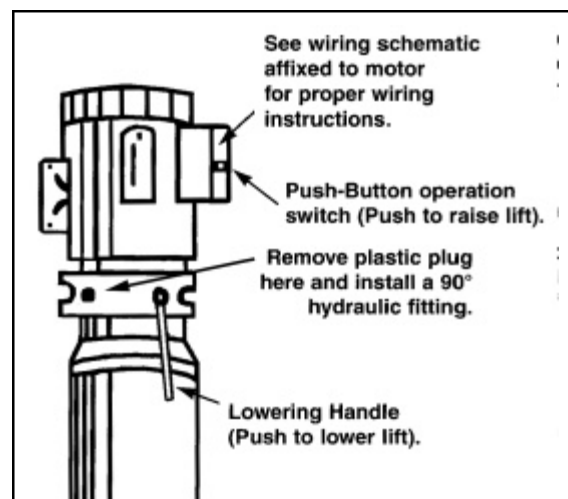

STEP THIRTEEN

(Installation Of Swing Arms.)

1. Install swing arms as described below. Grease the carriage tube and all pivot pins prior to installation.

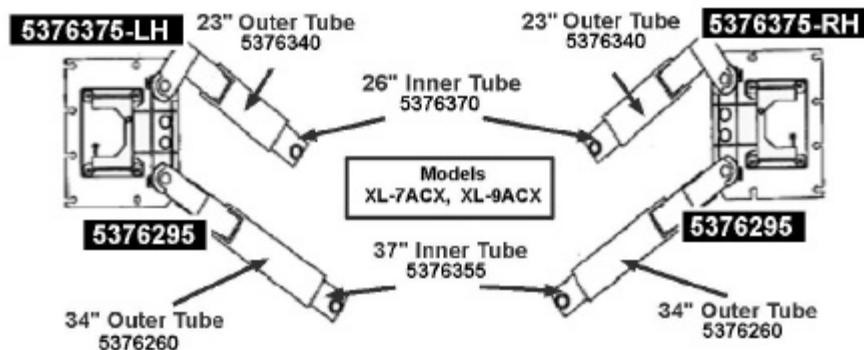
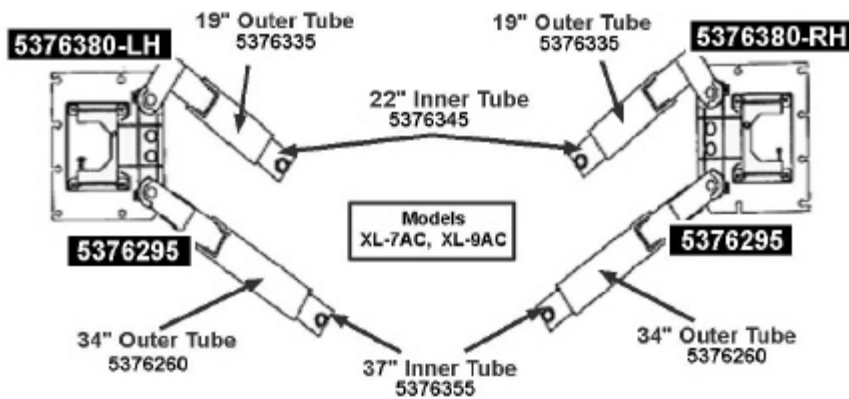
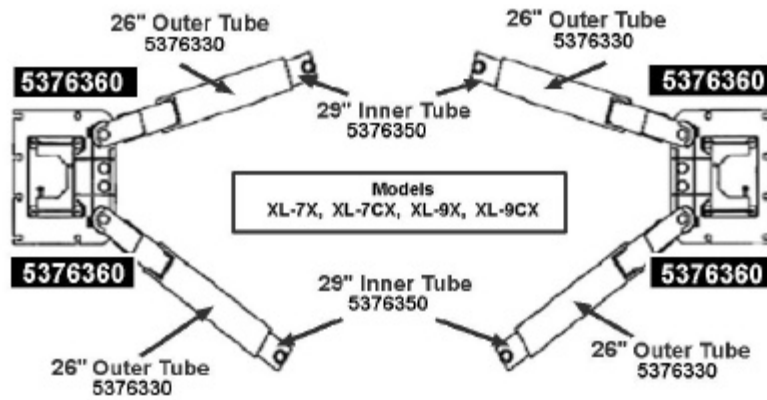
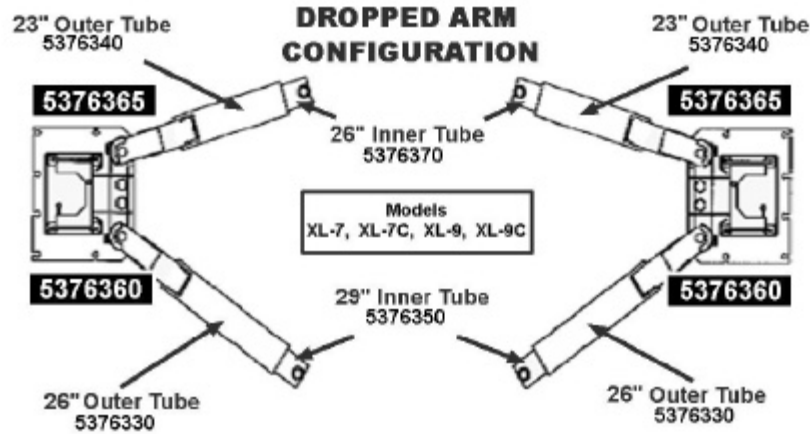

Revised 6/2/01

WARNING

IMPORTANT LEVELING INSTRUCTIONS

Before operating your lift, check to make sure that both "A" and "B" measurements are EQUAL.

The swing arms must be level before operation.

If your swing arms are not level shim the columns as required.

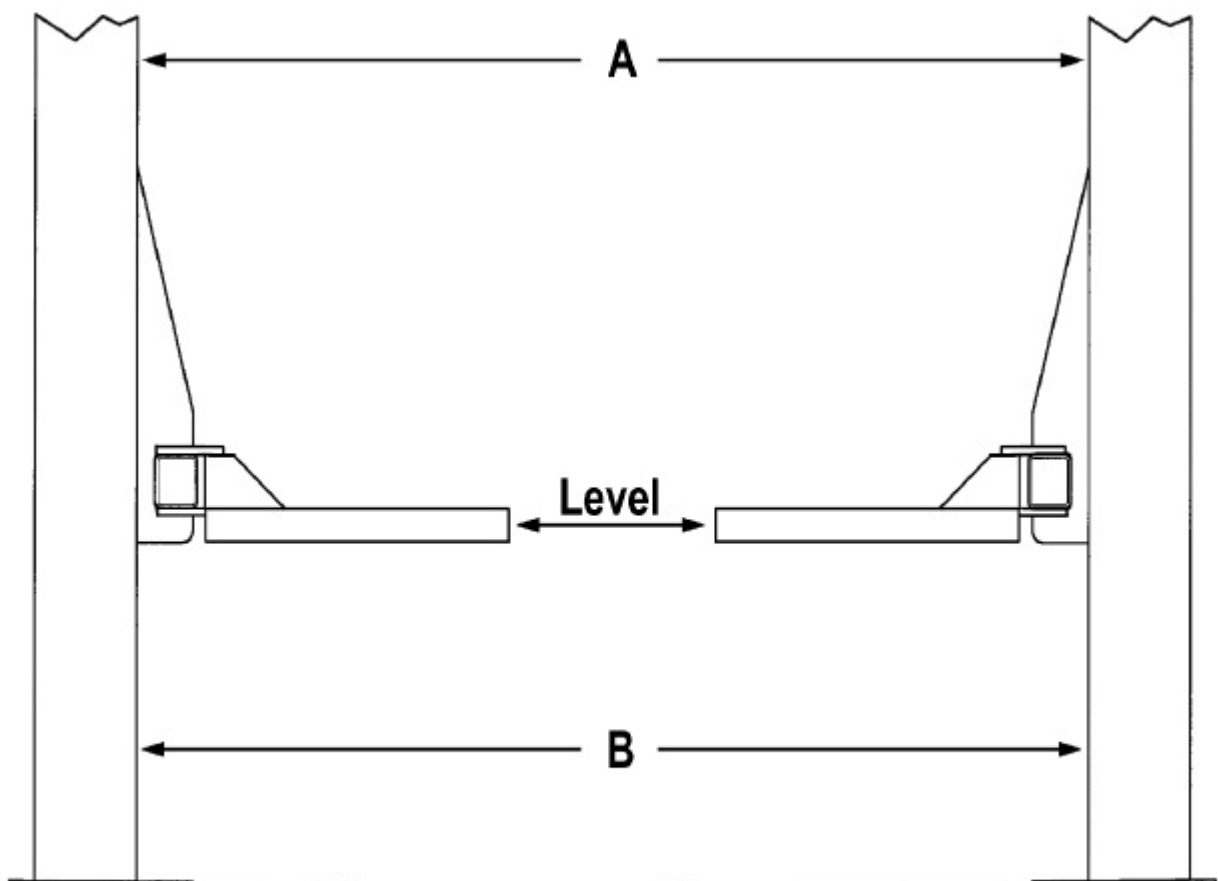

TO RAISE LIFT

- ✓ Read Operating and Safety manuals before using lift.
- ✓ Always lift a vehicle according to the manufacturers recommended lifting points.
- ✓ Position vehicle between columns.
- ✓ Adjust swing arms so that the vehicle is positioned with the center of gravity midway between pads.
- ✓ Use truck adapters as needed. Never exceed 9" of pad height.
- ✓ Raise lift by depressing button until supports contact underside of the vehicle. Recheck to make sure vehicle is secure.
- ✓ Raise vehicle to desired working height. Lower vehicle into nearest safety.
- ✓ Always ensure safeties are engaged before any attempt is made to work on or near vehicle.

TO LOWER THE LIFT

- ✓ First, raise the lift to clear the clear safeties.
- ✓ Raise safeties by pulling handles on each column.
- ✓ Be sure tool trays, stands or personnel are removed from under vehicle.
- ✓ Lower vehicle by activating lowering handle.
- ✓ Before removing vehicle from lift area, position lift arms and supports to provide an unobstructed exit.
- ✓ **NEVER**, drive over lift arms.

REQUIRED MONTHLY MAINTENANCE

- ✓ Check arm restraints for proper operation.
- ✓ Check all chain/cable connections, bolts and pins to insure proper mounting.
- ✓ Visually inspect safeties for proper operation.
- ✓ Lubricate columns with grease.
- ✓ Inspect all anchor bolts and retighten if necessary.
- ✓ Check columns for squareness and plumb.
- ✓ Inspect all arm pivot pins making sure they are properly secured.
- ✓ Check equalizer cable tension, adjust if necessary.
- ✓ Inspect all lift pads, replace if necessary.
- ✓ If lift is equipped with overhead cut-off switch, check for proper operation.

WARNING

1. **WARNING:** If cement anchor bolts are loose, or any component of the lift is found to be defective, **DO NOT USE LIFT!**
2. Never operate the lift with any person or equipment below.
3. Never exceed rated capacity.
4. Always insure safeties are engaged before any attempt is made to work on or near vehicle.
5. Never leave lift in an elevated position unless the safeties are engaged.
6. Do not permit electric motor to get wet! Motor damage caused by dampness is not covered under warranty.



NEVER LIFT ANY VEHICLE IN ANY MANNER WITH LESS THAN FOUR (4) ARMS. RATED CAPACITY OF EACH LIFT ARM IS NO GREATER THAN ONE FOURTH (1/4) OF THE OVERALL LIFTING CAPACITY.



Clear area if vehicle is in danger of falling.

©



Position vehicle with center of gravity midway between adapters.

©



CAUTION
Lift to be used by trained operator only.

©



CAUTION
Authorized personnel only in lift area.

©



Remain clear of lift when raising or lowering vehicle.

©



Avoid excessive rocking of vehicle while on lift.

©

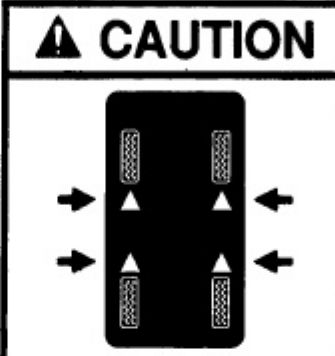

CAUTION
Use vehicle manufacturer's lift points.

©



CAUTION
Always use safety stands when removing or installing heavy components.

©



Do not override self-closing lift controls.

©

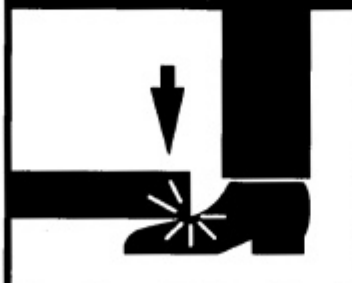

Keep feet clear of lift while lowering.

©



CAUTION
Use height extenders when necessary to ensure good contact.

©



CAUTION
Auxiliary adapters may reduce load capacity.

©

The messages and pictographs shown are generic in nature and are meant to generally represent hazards common to all automotive lifts regardless of specific style.

Funding for the development and validation of these labels was provided by the Automotive Lift Institute, PO Box 33116 Indialantic, FL. 32903.

They are protected by copyright. Set of labels may be obtained from ALI or its member companies.

© 1992 by ALI, Inc.

ALI/WL101w

The messages and pictographs shown are generic in nature and are meant to generally represent hazards common to all automotive lifts regardless of specific style.

Funding for the development and validation of these labels was provided by the Automotive Lift Institute, PO Box 33116 Indialantic, FL. 32903.

They are protected by copyright. Set of labels may be obtained from ALI or its member companies.

© 1992 by ALI, Inc.

ALI/WL101c

Bend-Pak
1645 Lemonwood Dr.
Santa Paula, CA. 93060

Tel: 1-805-933-9970
Fax: -1805-933-9160

www.bendpak.com