



WARNING

PLEASE READ THE ENTIRE CONTENTS OF THIS MANUAL PRIOR TO INSTALLATION AND OPERATION. BY PROCEEDING YOU AGREE THAT YOU FULLY UNDERSTAND AND COMPREHEND THE FULL CONTENTS OF THIS MANUAL. FORWARD THIS MANUAL TO ALL OPERATORS. FAILURE TO OPERATE THIS EQUIPMENT AS DIRECTED MAY CAUSE INJURY OR DEATH.



CAUTION

The safe operating temperature range for this product is 41° F. - 104 °F.

REV C 07-15-08

INSTALLATION AND OPERATION MANUAL

**12,000 POUND CAPACITY
COMMERCIAL GRADE
FOUR-POST OPEN FRONT
ALIGNMENT LIFTS**

**Models:
HDO-12LS-C
HDO-12LSX-C**



Do not operate this machine until you read and understand all the dangers, warnings and cautions in this manual.

Keep this operation manual near the machine at all times. Make sure that ALL USERS read this manual.

SHIPPING DAMAGE CLAIMS

When this equipment is shipped, title passes to the purchaser upon receipt from the carrier. Consequently, claims for the material damaged in shipment must be made by the purchaser against the transportation company at the time shipment is received.

BE SAFE

Your new lift was designed and built with safety in mind. However, your overall safety can be increased by proper training and thoughtful operation on the part of the operator. DO NOT operate or repair this equipment without reading this manual and the important safety instructions shown inside.



1645 Lemonwood Dr.
Santa Paula, CA. 93060, USA
Toll Free 1-800-253-2363
Tel: 1-805-933-9970
Fax: 1-805-933-9160
www.bendpak.com

12,000 POUND CAPACITY, COMMERCIAL GRADE FOUR POST OPEN FRONT ALIGNMENT AUTO / TRUCK LIFT

This instruction manual has been prepared especially for you.
Your new lift is the product of over 35 years of continuous research, testing and development;
it is the most technically advanced lift on the market today.

READ THIS ENTIRE MANUAL BEFORE INSTALLATION & OPERATION BEGINS.

RECORD HERE THE LIFT AND
POWER UNIT INFORMATION WHICH IS
LOCATED ON THE SERIAL NUMBER
DATA PLATES ON THE LIFT AND
ON THE POWER UNIT

Power Unit Model # _____
Power Unit Date Of Mfg. _____
Power Unit Serial # _____

This information is required when
calling for parts or warranty issues.

1645 Lemonwood Dr., Santa Paula, CA 93060 USA Tel: 1-805-933-9970 Fax: 1-805-933-9160 www.bendpak.com		
Model No.	Lifting Capacity	Serial No.
Date of Mfg.	Power Unit No.	Voltage / Amperage
Cable Length	A	C
	B	D

PRODUCT WARRANTY

BendPak 4-Post Lifts are covered under warranty for five years on equipment structure, to be free of defects in material and workmanship. Power units, hydraulic cylinders, and all other assembly components such as turnplates, slip plates, cables, chains, valves, switches etc. are covered under warranty for one year against defects in material or workmanship under normal use. BendPak Inc. shall repair or replace at their option for the warranty period those parts returned to the factory freight prepaid which prove upon inspection to be defective. BendPak Inc. will pay labor costs for the first 12 months only on parts returned as previously described.

The warranty does not extend to...

- ◆ defects caused by ordinary wear, abuse, misuse, shipping damage, improper installation, voltage or lack of required maintenance;
- ◆ damages resulting from purchaser's neglect or failure to operate products in accordance with instructions provided in the owner's manual(s) and/or other accompanying instructions supplied;
- ◆ normal wear items or service normally required to maintain the product in a safe operating condition;
- ◆ any component damaged in shipment;
- ◆ other items not listed but may be considered general wear parts;
- ◆ damage caused by rain, excessive humidity, corrosive environments or other contaminants.

THESE WARRANTIES DO NOT EXTEND TO ANY COSMETIC DEFECT NOT INTERFERING WITH EQUIPMENT FUNCTIONALITY OR ANY INCIDENTAL, INDIRECT, OR CONSEQUENTIAL LOSS, DAMAGE, OR EXPENSE THAT MAY RESULT FROM ANY DEFECT, FAILURE, OR MALFUNCTION OF A BENDPAK INC. PRODUCT OR THE BREACH OR DELAY IN PERFORMANCE OF THE WARRANTY.

**WARRANTY IS NOT VALID UNLESS
WARRANTY CARD IS RETURNED.**

IMPORTANT NOTICE

Do not attempt to install this lift if you have never been trained on basic automotive lift installation procedures. Never attempt to lift components without proper lifting tools such as forklift or cranes. Stay clear of any moving parts that can fall and cause injury. These instructions must be followed to insure proper installation and operation of your lift. Failure to comply with these instructions can result in serious bodily harm and void product warranty. Manufacturer will assume no liability for loss or damage of any kind, expressed or implied resulting from improper installation or use of this product.

PLEASE READ ENTIRE MANUAL PRIOR TO INSTALLATION.

DEFINITIONS OF HAZARD LEVELS

Identify the hazard levels used in this manual with the following definitions and signal words:



DANGER

Watch for this symbol: It Means: Immediate hazards which will result in severe personal injury or death.



WARNING

Watch for this symbol: It Means: Hazards or unsafe practices which could result in severe personal injury or death.



CAUTION

Watch for this symbol: It Means: Hazards or unsafe practices which may result in minor personal injury, product or property damage.

OWNER'S RESPONSIBILITY

To maintain the lift and user safety, the responsibility of the owner is to read and follow these instructions:

- ◆ Follow all installation and operation instructions.
- ◆ Make sure installation conforms to all applicable Local, State, and Federal Codes, Rules, and Regulations; such as State and Federal OSHA Regulations and Electrical Codes.
- ◆ Carefully check the lift for correct initial function.
- ◆ Read and follow the safety instructions. Keep them readily available for machine operators.
- ◆ Make certain all operators are properly trained, know how to safely and correctly operate the unit, and are properly supervised.
- ◆ Allow unit operation only with all parts in place and operating safely.
- ◆ Carefully inspect the unit on a regular basis and perform all maintenance as required.
- ◆ Service and maintain the unit only with authorized or approved replacement parts.
- ◆ Keep all instructions permanently with the unit and all decals on the unit clean and visible.

BEFORE YOU BEGIN

Receiving:

The shipment should be thoroughly inspected as soon as it is received. The signed bill of lading is acknowledgement by the carrier of receipt in good condition of shipment covered by your invoice. If any of the goods called for on this bill of lading are shorted or damaged, do not accept them until the carrier makes a notation on the freight bill of the shorted or damaged goods. Do this for your own protection.

NOTIFY THE CARRIER AT ONCE if any hidden loss or damage is discovered after receipt and request the carrier to make an inspection. If the carrier will not do so, prepare a signed statement to the effect that you have notified the carrier (on a specific date) and that the carrier has failed to comply with your request.

IT IS DIFFICULT TO COLLECT FOR LOSS OR DAMAGE AFTER YOU HAVE GIVEN THE CARRIER A CLEAR RECEIPT. File your claim with the carrier promptly. Support your claim with copies of the bill of lading, freight bill, invoice, and photographs, if available. Our willingness to assist in helping you process your claim does not make BendPak responsible for collection of claims or replacement of lost or damaged materials.

TABLE OF CONTENTS

<u>Contents</u>	<u>Page No.</u>
Warranty / Serial Number Information	2
Definitions of Hazard Levels	3
Owner's Responsibility	3
Before You Begin.	3
Installers / Operators Agreement / Protective Equipment	5
Introduction.	6
Safety / Warning Instructions	6
Tools Required.	7
Step 1 / Selecting Site	7
Step 2 / Floor Requirements	7
Concrete Specifications.	7
Assembly View / Description of Parts	8
Floor Plan / Specifications	9
Power Unit Location.	10
Step 3 / Column and Cross Tube Installation.	11-12
Step 4 / Anchoring The Columns	12-13
Step 5 / Raising the Cross Tubes	13
Step 6 / Powerside Runway Installation	14
Step 7 / Offside Runway Installation	14
Step 8 / Cable Sheave Installation	15-16
Step 9 Cable Installation	16-17
Step 10 / Power Unit Installation	17
Step 11 / Routing Hydraulic Hoses	17-19
Step 12 / Routing Air Lines	19
Step 13 / Power Unit Hook Up	20-22
Step 14 / Inspecting Slack Safety Springs	22
Step 15 / Lift Start Up / Final Adjustments	22-23
Step 16 / Attaching Approach Ramps / Tire stops.	23-24
Step 17 / Leveling System	24
Step 18 Bleeding	25
Optional Equipment Installation.	26-27
Step 19 / Operation/ Maintenance	28-33
Troubleshooting Guide	34-37
Part Number Lists	38-41
Maintenance Records.	41
Installation Form	42

**INSTALLER / OPERATOR
PLEASE READ AND FULLY
UNDERSTAND.
BY PROCEEDING YOU AGREE TO
THE FOLLOWING.**



Failure to follow danger, warning, and caution instructions may lead to serious personal injury or death to operator or bystander or damage to property.



Please read entire manual prior to installation. Do not operate this machine until you read and understand all the dangers, warnings and cautions in this manual. For additional copies or further information, contact:

BendPak Inc. / Ranger Products

1645 Lemonwood Dr.

Santa Paula, CA. 93060

1-805-933-9970

www.bendpak.com

**INSTALLER / OPERATOR
PROTECTIVE EQUIPMENT**

Personal protective equipment helps makes installation and operation safer, however, it does not take the place of safe operating practices. Always wear durable work clothing during any installation and/or service activity. Shop aprons or shop coats may also be worn, however loose fitting clothing should be avoided. Tight fitting leather gloves are recommended to protect technician hands when handling parts. Sturdy leather work shoes with steel toes and oil resistant soles should be used by all service personnel to help prevent injury during typical installation and operation activities.

Eye protection is essential during installation and operation activities. Safety glasses with side shields, goggles, or face shields are acceptable. Back belts provide support during lifting activities and are also helpful in providing worker protection. Consideration should also be given to the use of hearing protection if service activity is performed in an enclosed area, or if noise levels are high.



- ◆ I have visually inspected the site where the lift is to be installed and verified the concrete to be in good condition and free of cracks or other defects. I understand that installing a lift on cracked or defective concrete could cause lift failure resulting in personal injury or death.
- ◆ I understand that a level floor is required for proper installation and level lifting.
- ◆ I understand that I am responsible if my floor is of questionable slope and that I will be responsible for all charges related to pouring a new level concrete slab if required and any charges.
- ◆ I understand that the lifts are supplied with concrete fasteners meeting the criteria of the American National Standard "Automotive Lifts - Safety Requirements for Construction, Testing, and Validation" ANSI/ALI ALCTV-1998, and that I will be responsible for all charges related to any special regional structural and/or seismic anchoring requirements specified by any other agencies and/or codes such as the Uniform Building Code (UBC) and/or International Building Code (IBC).
- ◆ I will assume full responsibility for the concrete floor and condition thereof, now or later, where the above equipment model(s) are to be installed. Failure to follow danger, warning, and caution instructions may lead to serious personal injury or death to operator or bystander or damage to property.
- ◆ I understand that Bendpak lifts are designed to be installed in indoor locations only. Failure to follow installation instructions may lead to serious personal injury or death to operator or bystander or damage to property or lift.



THIS SYMBOL POINTS OUT IMPORTANT SAFETY INSTRUCTIONS WHICH IF NOT FOLLOWED COULD ENDANGER THE PERSONAL SAFETY AND/OR PROPERTY OR YOURSELF AND OTHERS AND CAN CAUSE PERSONAL INJURY OR DEATH. READ AND FOLLOW ALL INSTRUCTIONS IN THIS MANUAL BEFORE ATTEMPTING TO OPERATE THIS MACHINE.

INTRODUCTION

1. Carefully remove the crating and packing materials. **CAUTION!** Be careful when cutting steel banding material as items may become loose and fall causing personal harm or injury.

2. Check the voltage, phase and proper amperage requirements for the motor shown on the motor plate. Wiring should be performed by a certified electrician only.

IMPORTANT SAFETY INSTRUCTIONS

Read these safety instructions entirely!

IMPORTANT NOTICE

Do not attempt to install this lift if you have never been trained on basic automotive lift installation procedures.

Never attempt to lift components without proper lifting tools such as forklift or cranes.

Stay clear of any moving parts that can fall and cause injury.

1. **READ AND UNDERSTAND** all safety warning procedures before operating lift.

2. **KEEP HANDS AND FEET CLEAR.** Remove hands and feet from any moving parts. Keep feet clear of lift when lowering. Avoid pinch points.

3. **KEEP WORK AREA CLEAN.** Cluttered work areas invite injuries.

4. Consider work area environment. Do not expose equipment to rain. **DO NOT** use in damp or wet locations. Keep area well lighted.

5. **ONLY TRAINED OPERATORS** should operate this lift. All non-trained personnel should be kept away from work area. Never let non-trained personnel come in contact with, or operate lift.

6. **USE LIFT CORRECTLY.** Use lift in the proper manner. Never use lifting adapters other than what is approved by the manufacturer.

7. **DO NOT** override self-closing lift controls.

8. **REMAIN CLEAR** of lift when raising or lowering vehicle.

9. **CLEAR AREA** if vehicle is in danger of falling.

10. **ALWAYS INSURE** that the safeties are engaged before any attempt is made to work on or near vehicle.

11. **DRESS PROPERLY.** Non-skid steel-toe footwear is recommended when operating lift.

12. **GUARD AGAINST ELECTRIC SHOCK.** This lift must be grounded while in use to protect the operator from electric shock. Never connect the green power cord wire to a live terminal. This is for ground only.



13. **DANGER!** The power unit used on this lift contains high voltage. Disconnect power at the receptacle before performing any electrical repairs. Secure plug so that it cannot be accidentally plugged in during service.



14. **WARNING! RISK OF EXPLOSION.** This equipment has internal arcing or sparking parts which should not be exposed to flammable vapors. This machine should not be located in a recessed area or below floor level.



15. **MAINTAIN WITH CARE.** Keep lift clean for better and safer performance. Follow manual for proper lubrication and maintenance instructions. Keep control handles and/or buttons dry, clean and free from grease and oil.

16. **STAY ALERT.** Watch what you are doing. Use common sense. Be aware.

17. **CHECK FOR DAMAGED PARTS.** Check for alignment of moving parts, breakage of parts or any condition that may affect its operation. Do not use lift if any component is broken or damaged.

18. **NEVER** remove safety related components from the lift. Do not use lift if safety related components are damaged or missing.

TOOLS REQUIRED

- ◆ Rotary Hammer Drill or Similar
- ◆ 3/4" Masonry Bit
- ◆ Hammer
- ◆ 4 Foot Level
- ◆ Open-End Wrench Set: 7/16" - 1-1/8"
- ◆ Socket And Ratchet Set: 7/16" - 1-1/8"
- ◆ Hex-Key / Allen Wrench Set
- ◆ Large Crescent Wrench
- ◆ Large Pipe Wrench
- ◆ Crow Bar
- ◆ Chalk Line
- ◆ Medium Flat Screwdriver
- ◆ Tape Measure: 25 Foot Minimum
- ◆ Needle Nose Pliers

IMPORTANT NOTICE

These instructions must be followed to insure proper installation and operation of your lift. Failure to comply with these instructions can result in serious bodily harm and void product warranty.

Manufacturer will assume no liability for loss or damage of any kind, expressed or implied resulting from improper installation or use of this product.

Please read entire manual prior to installation.

STEP 1

(Selecting Site)

Before installing your new lift, check the following.

1. **LIFT LOCATION:** Always use architects plans when available. Check layout dimension against floorplan requirements making sure that adequate space is available.
2. **OVERHEAD OBSTRUCTIONS:** The area where the lift will be located should be free of overhead obstructions such as heaters, building supports, electrical lines etc.
3. **DEFECTIVE FLOOR:** Visually inspect the site where the lift is to be installed and check for cracked or defective concrete.



4. **OPERATING TEMPERATURE.** Operate lift only between temperatures of 41° -104° F.
5. Lift is designed for **INDOOR INSTALLATION ONLY.**

STEP 2

(Floor Requirements)



This lift must be installed on a solid level concrete floor with no more than 3-degrees of slope. Failure to do so could cause personal injury or death.

A level floor is suggested for proper use and installation and level lifting. If a floor is of questionable slope, consider a survey of the site and/or the possibility of pouring a new level concrete slab.



- ◆ **DO NOT** install or use this lift on any asphalt surface or any surface other than concrete.
- ◆ **DO NOT** install or use this lift on expansion seams or on cracked or defective concrete.
- ◆ **DO NOT** install or use this lift on a second / elevated floor without first consulting building architect.
- ◆ **DO NOT** install or use this lift outdoors.

CONCRETE SPECIFICATIONS

LIFT MODEL

CONCRETE REQUIREMENTS

HDO-12LS-C
HDO-12LSX-C

4" Min. Thickness
4" Min. Thickness



DANGER!

All models **MUST** be installed on 2500 PSI concrete only conforming to the minimum requirements shown above. New concrete must be adequately cured by at least 28 days minimum.

! DANGER

When removing the lift from shipping angles pay close attention as the posts can slide and can cause injury. Prior to removing the bolts make sure the posts are held securely by a fork lift or some other heavy lifting devise.

ASSEMBLY VIEW

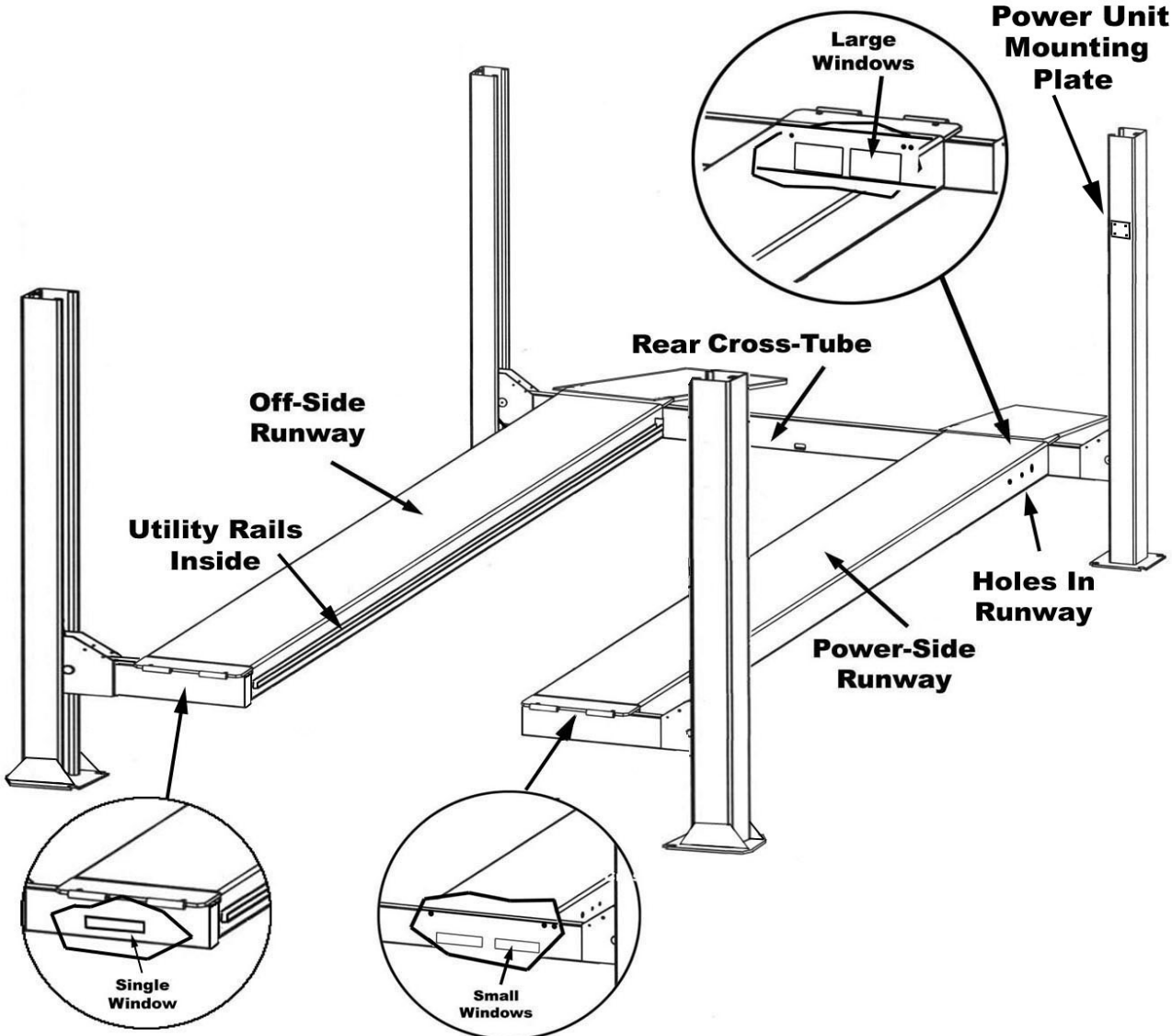

IMPORTANT NOTE

The power unit must be installed at the location shown above. It is important to locate the POWER-SIDE runway (with cylinder) on the SAME SIDE as power unit location. Rolling Jack / Utility rails on the side of each runway MUST be installed to the inside.

FLOORPLAN

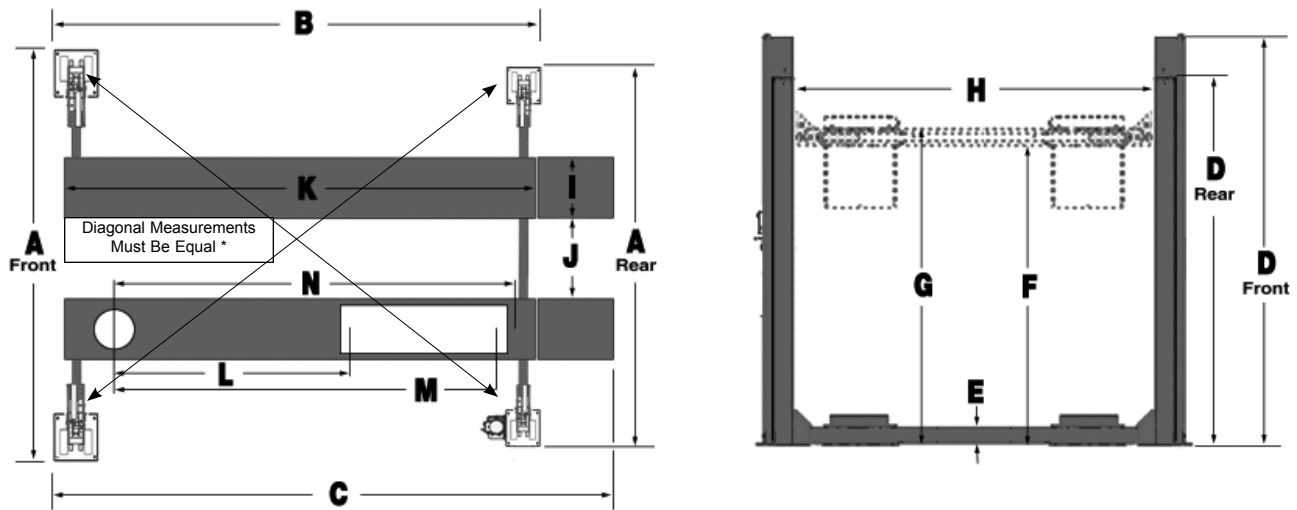

* IMPORTANT NOTE *
Check Diagonal Measurements.
To Confirm Square Layout; Diagonal Measurements Must Be Equal.

MODEL	HDO-12LS-C	HDO-12LSX-C
Lifting Capacity*	12,000 lbs. / 5443 Kg.	12,000 lbs. / 5443 Kg.
*Max Capacity / Front Axle	6,000 lbs. / 2722 Kg.	6,000 lbs. / 2722 Kg.
*Max Capacity / Rear Axle	6,000 lbs. / 2722 Kg.	6,000 lbs. / 2722 Kg.
A - Overall Width / Front	139" / 3531 mm.	139" / 3531 mm.
A - Overall Width / Rear	130" / 3302 mm.	130" / 3302 mm.
B - Outside Length	183-1/2" / 4661 mm.	207-1/2" / 5270 mm.
C - Overall Length	214-1/4" / 5442 mm.	238-1/4" / 6052 mm.
D - Height of Columns / Front	100" / 2540 mm.	100" / 2540 mm.
D - Height of Columns / Rear	88" / 2235 mm.	88" / 2235 mm.
E - Min. Runway Height	8-3/4" / 222 mm.	8-3/4" / 222 mm.
F - Max. Rise	70" / 1778 mm.	70" / 1778 mm.
G - Max. Lifting Height	78-3/4" / 2000 mm.	78-3/4" / 2000 mm.
H - Width Between Columns	116" / 2946 mm.	116" / 2946 mm.
I - Runway Width	20" / 508 mm.	20" / 508 mm.
J - Width Between Runways	39" / 991 mm.	39" / 991 mm.
K - Length of Runways	174" / 4420 mm.	198" / 5029 mm.
L - Min. 4-Wheel Alignment (*)	72" / 1828 mm.	72" / 1828 mm.
M - Max. 4-Wheel Alignment (*)	135" / 3428 mm.	165" / 4191 mm.
N - Max 2-Wheel Alignment (*)	151" / 3835 mm.	175" / 4445 mm.
Locking Positions	12	12
Lock Spacing	Every 4" / 102 mm.	Every 4" / 102 mm.
Lifting Time	60 Seconds	60 Seconds
Standard Motor (**)	220 VAC / 60 Hz. 1Ph.	220 VAC / 60 Hz. 1Ph.

* May vary depending on wheel size.

** Special Voltages Available Upon Request.

The design, material and specifications are subject to change without notice.

POWER UNIT LOCATION

The power unit will be located at "X" location shown below. It is important to locate the POWERSIDE runway (with cylinder) on the SAME SIDE as the power unit location.
Note the location of the bulkhead fitting holes in the POWERSIDE runway.
Utility rails on the side of each runway MUST be installed to the inside.

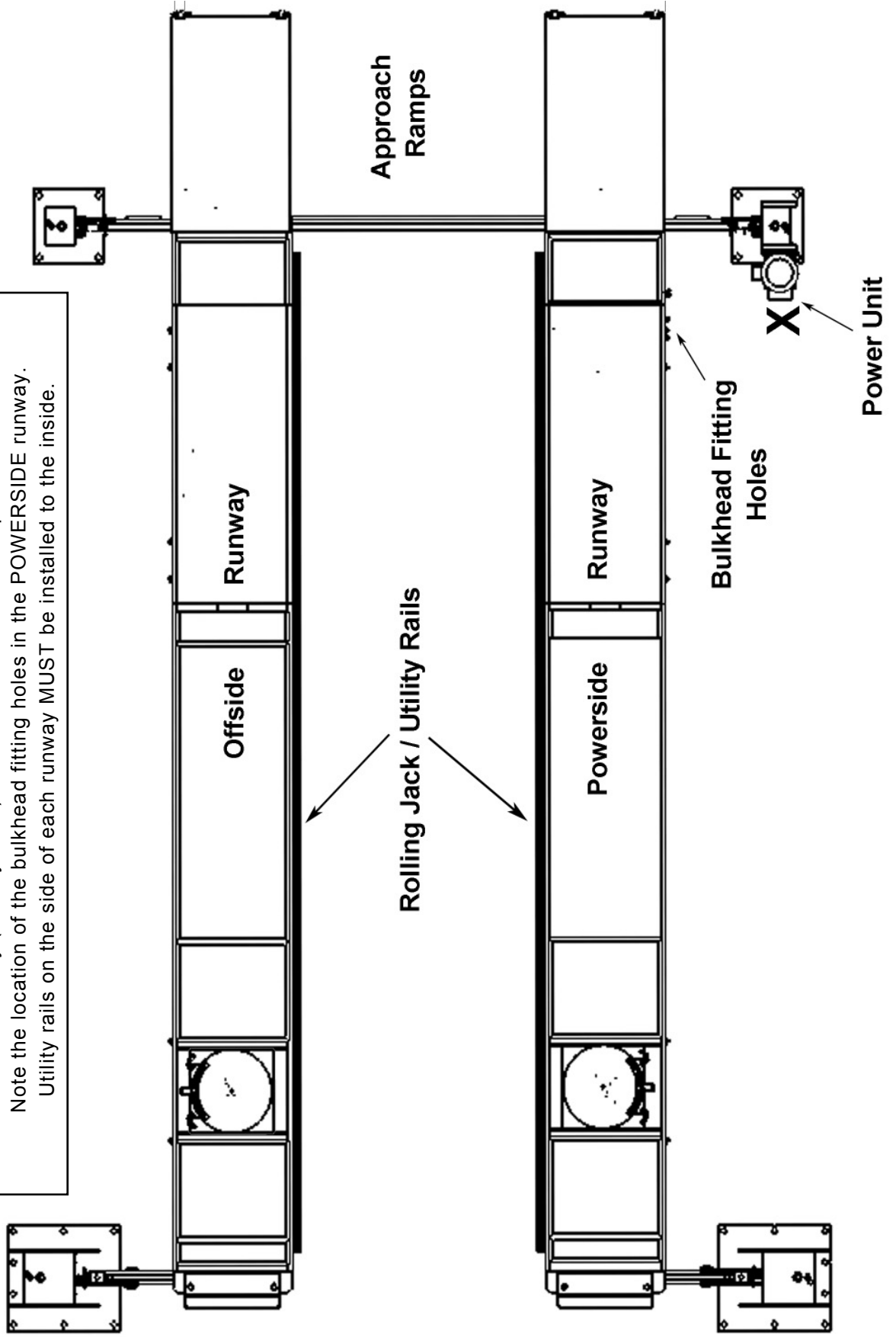

STEP 3

(Column & Cross Tube Installation)

1. Place a chalk line on the floor according to the floor plan layout. Pay attention to the Power Unit location. Locate and stand the Columns at their respective locations. **DO NOT BOLT** columns down at this time. Use caution to prevent the Columns from falling over. (See Fig. 3.1)

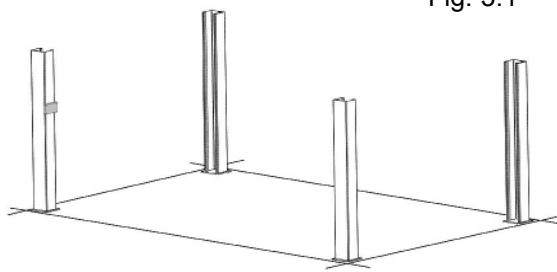

Fig. 3.1

2. To estimate the shim requirements, place a target on floor at each Column position and record the readings. Find the highest of the four locations then find the difference between each of the remaining Columns. This difference is the estimated amount of shim thickness that will be required at each Column. (See Fig. 3.2)

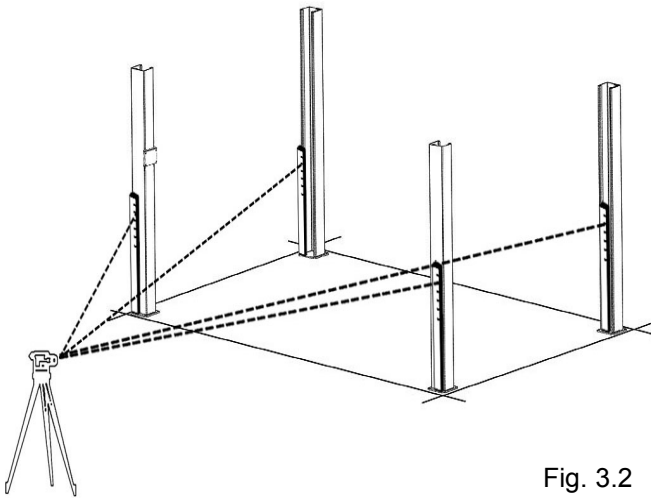

Fig. 3.2

Note: The maximum shim thickness recommended by the factory is no more than 1/2" per Column using shims and anchors provided with the lift. A maximum shim thickness of 2" is possible by ordering optional shim plates. Contact your authorized BendPak Distributor for ordering information.

3. Using a forklift or crane, raise the Cross tubes (making sure the Plastic Slide Blocks are still in position) and drop down into the top of the Columns. NOTE: The sheave windows should be positioned inward and adjacent the Power Unit Column. (See Fig. 3.3)

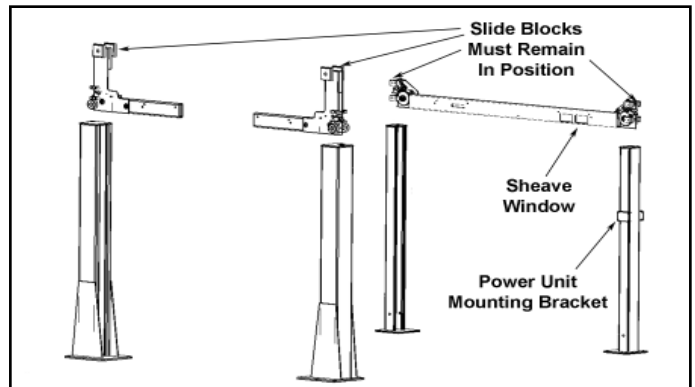
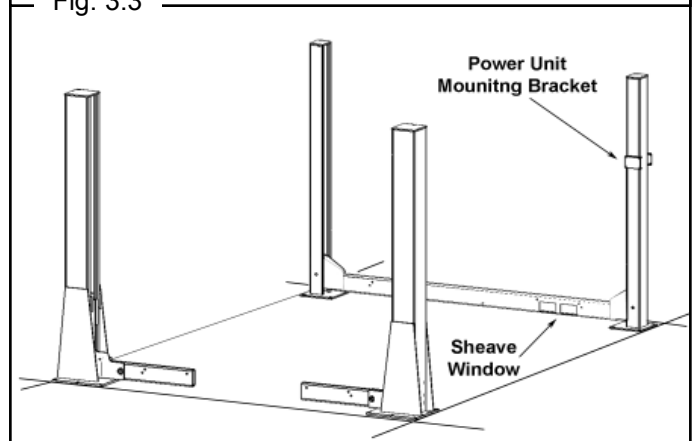

Fig. 3.3



4. With the Columns standing and the Cross Tubes in position, install the Safety Ladders. Pass the ladders through the Column openings and drop down through the Slide Block guide slots on the Cross Tube until the Ladders come to rest on the Base Plates. **DO NOT BOLT** Columns down at this time. (See Fig. 3.4 - 3.5)

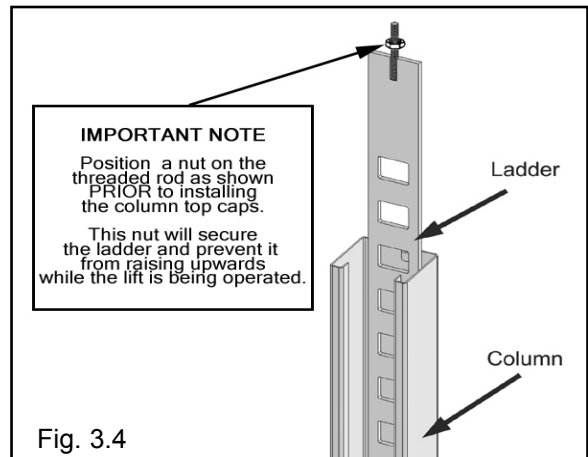

Fig. 3.4

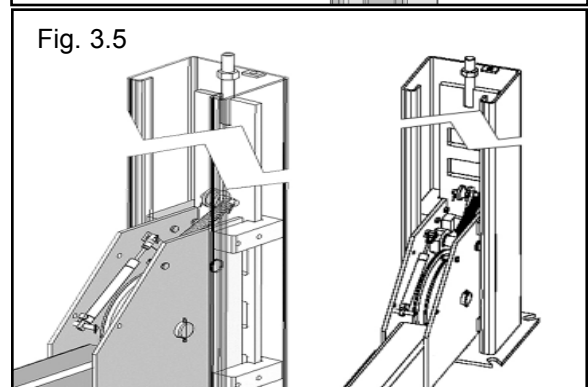
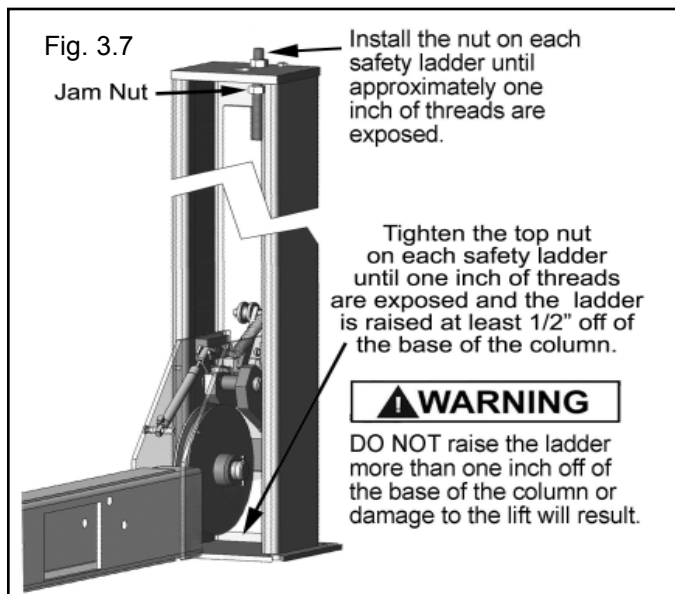
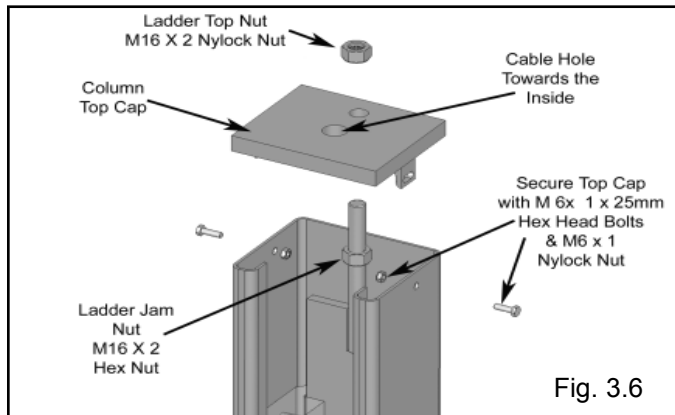

Fig. 3.5

5. The Columns and Cross Tubes will now be in position and spaced properly for the Runways.

6. Install the Column TOP CAPS using the M10 X 1.50 X 50 Hex Bolts, Nuts & Washers. Install the Nut on each Safety Ladder until 1/2" of threads are exposed and the ladder is raised at least 1/2" off of the base of the Column.

NOTE: Raise the ladder at least 1/2" off of the base of the column or damage to the lift will occur. Be sure to position the cable hole INWARD. (See Fig. 3.6 -3.7)



STEP 4

(Anchoring The Columns)

1. Before proceeding, double check the measurements and make certain that the Bases of each Column are square and aligned with the chalk line. (See Fig. 4.1)

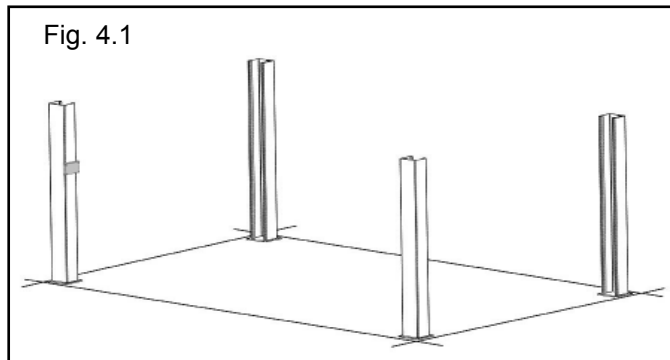

ALWAYS WEAR SAFETY GOGGLES.

2. Using the Base Plate on each Column as a guide, drill each anchor hole approximately 4-1/2" deep using a rotary hammer drill and 3/4" concrete bit. (See Fig. 4.2)

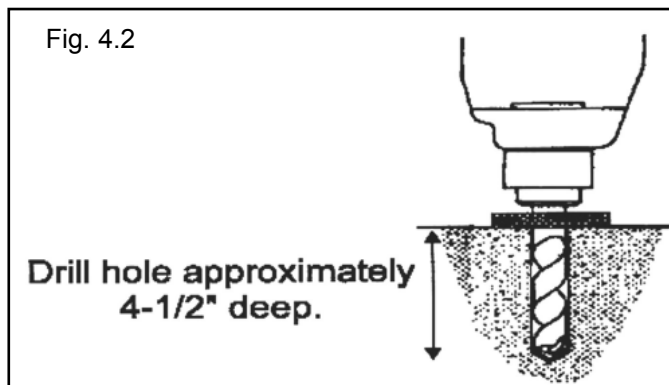

3. After drilling, remove dust thoroughly from each hole using compressed air and/or bristle brush. Make certain that the Columns remain aligned with the chalk line.

4. Assemble the Washers and Nuts on the Anchors then tap into each hole with a hammer until the Washer rests against the Base Plate. Be sure that if shimming is required, enough threads are left exposed. (See Fig. 4.3)

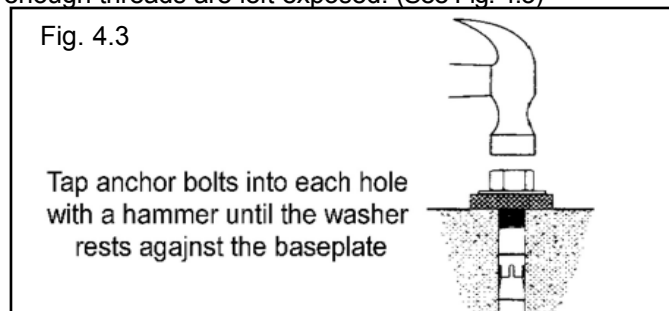

5. If shimming is required, insert the Shims as necessary under the Base Plate so that when the Anchor bolts are tightened, the Columns will be plumb. (See Fig. 4.4)

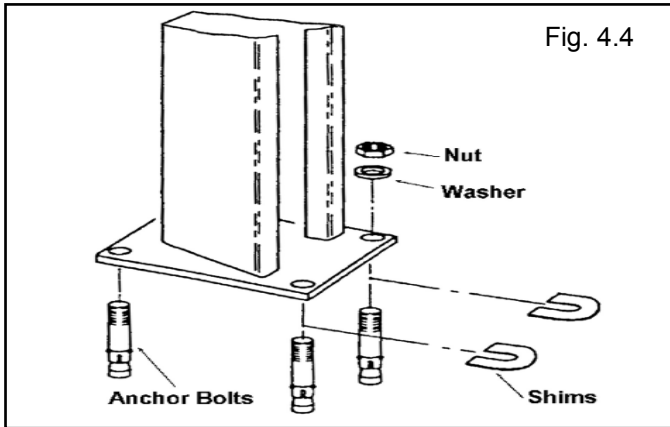

6. After any necessary Shims are installed, tighten each anchor nut two to three turns past finger tight. (See Fig. 4.5)

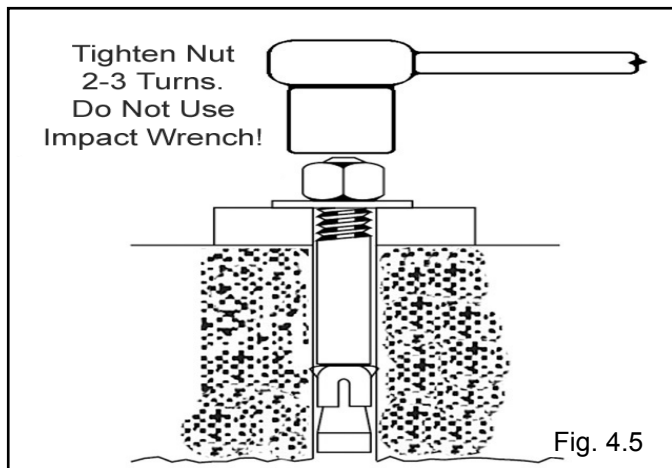

IMPORTANT - If Anchor Bolts do not hold when torqued to required amount, concrete must be replaced. Saw cut and remove 24" x 24" square area under each Column base then re-pour with reinforced 2500 PSI concrete to a depth of six inches minimum, keying new concrete under existing floor.

STEP 5

(Raising The Cross Tubes)

1. Before proceeding it will be necessary to first raise the Cross Tubes off the ground to facilitate Cable routing and final assembly.

2. Manually raise the Cross Tubes until the primary Safety Locks engage and rest on the lock position second down from the top of the ladder or approximately 66" off the ground. It is important that the SLACK SAFETY LOCK IS CLEARED. The Slack Safety Lock must never rest on the Safety Ladder. (See Fig. 5.1)

IMPORTANT NOTE
It is important that the SLACK SAFETY LOCK IS CLEARED. The slack safety lock must never rest on the safety ladder.

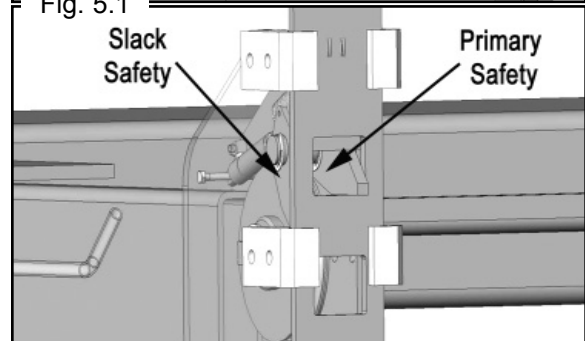
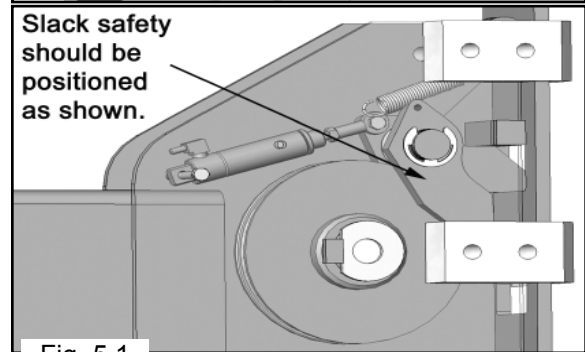
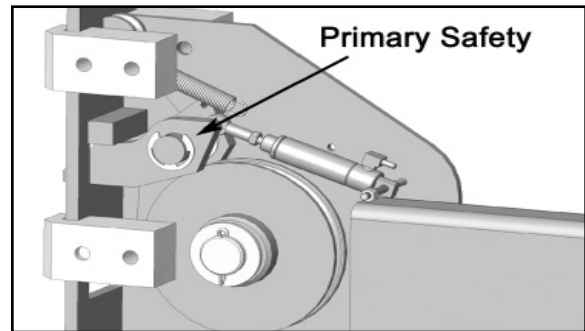

3. The Columns and Cross Tubes will now be in position and spaced properly for the Runways. (See Fig. 5.2)

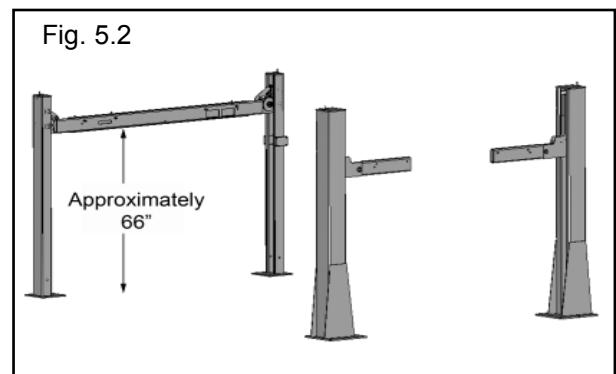

STEP 6

(Powerside Runway Installation)

1. Locate the Powerside Runway easily identified by the Cylinder and Sheave Roller mounting structures welded on the underside. The Powerside Runway will be positioned on the side of the lift where the Power Unit is installed.

(See Fig. 6.1)

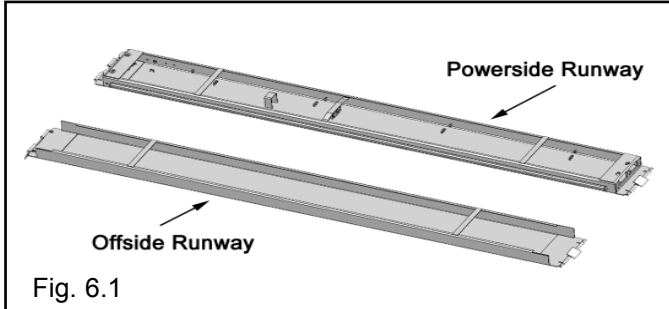

2. Install the Cylinder and Cable Block as shown.

(See Fig. 6.2 - 6.3)

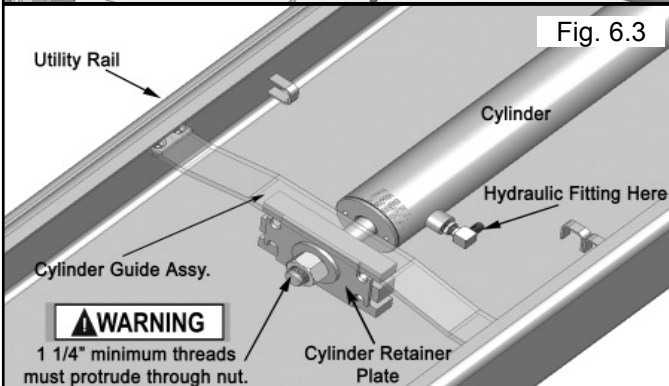
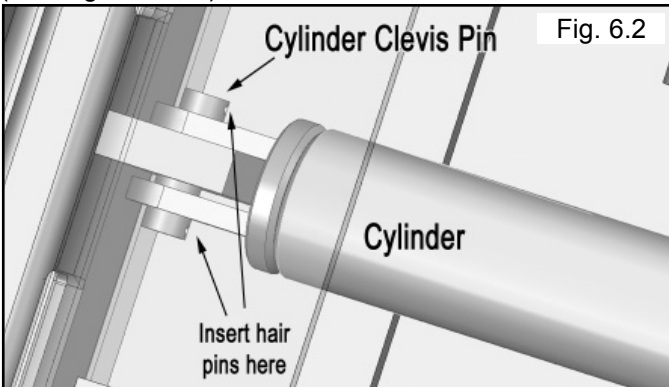

3. Remove any pre-installed Cable Sheaves from the Powerside runway making sure to pay attention to the order in which they are removed. (This will help at the time of re-installation.) (See Page 15)

4. Position the Powerside Runway on top of the Cross Tubes with the utility rail towards the center. The fitting holes located at the side of the Powerside Runway should be adjacent to the Power Unit Column. Align the holes in the Runway with the holes on the Cross Tubes and bolt together using four M12 x 7.75 x 90 Hex Head Bolts and Washers.

(See Fig. 6.4)

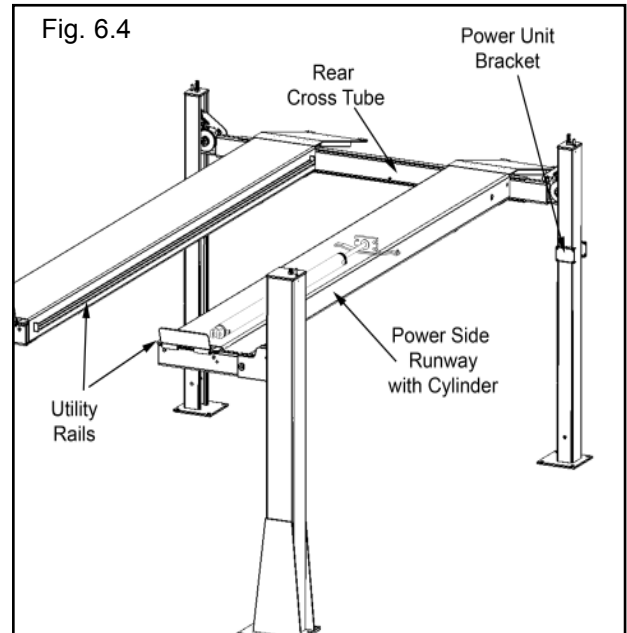

STEP 7

(Offside Runway Installation)

1. Position the Offside Runway on top of the Cross Tubes with the utility rail located inside. (See Fig. 7.1)

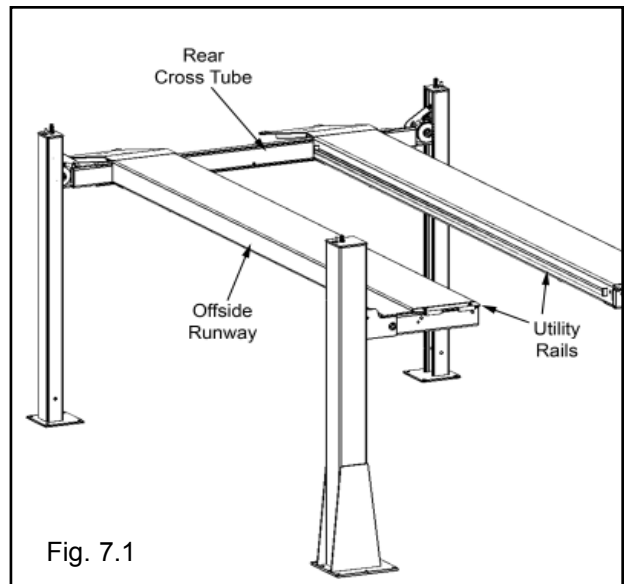

DANGER !

DO NOT PROCEED with cable installation or go near the lift work area unless visual confirmation is made of ALL Safety Locks. ALL locks MUST be engaged before proceeding. Failure to comply with these instructions may result in severe personal injury or death. (See page 13)

Model	Equalizer Cables (Note: Cables are Model Specific)	Part No.	Qty
A	HDO-12LS-C Cable Assy. (12mm x 3,404mm) ST (M22 x 2.5) Cable "A"	5595780	1
B	HDO-12LS-C Cable Assy. (12mm x 5,017mm) ST (M22 x 2.5) Cable "B"	5595781	1
C	HDO-12LS-C Cable Assy. (12mm x 8,115mm) ST (M22 x 2.5) Cable "C"	5595794	1
D	HDO-12LS-C Cable Assy. (12mm x 9,614mm) ST (M22 x 2.5) Cable "D"	5595795	1
A	HDO-12LSX-C Cable Assy. (12mm x 4,013mm) ST (M22 x 2.5) Cable "A"	5595784	1
B	HDO-12LSX-C Cable Assy. (12mm x 5,601mm) ST (M22 x 2.5) Cable "B"	5595785	1
C	HDO-12LSX-C Cable Assy. (12mm x 9,335mm) ST (M22 x 2.5) Cable "C"	5595798	1
D	HDO-12LSX-C Cable Assy. (12mm x 10,833mm) ST (M22 x 2.5) Cable "D"	5595799	1

IMPORTANT
 It will be necessary to remove the pins, cable guards and spacers prior to cable installation. You **MUST** re-install these components back to the same order as they are removed

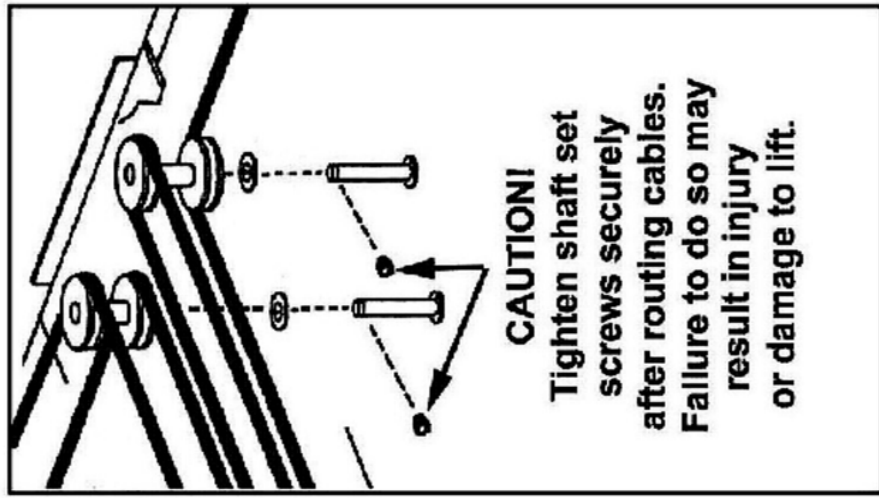
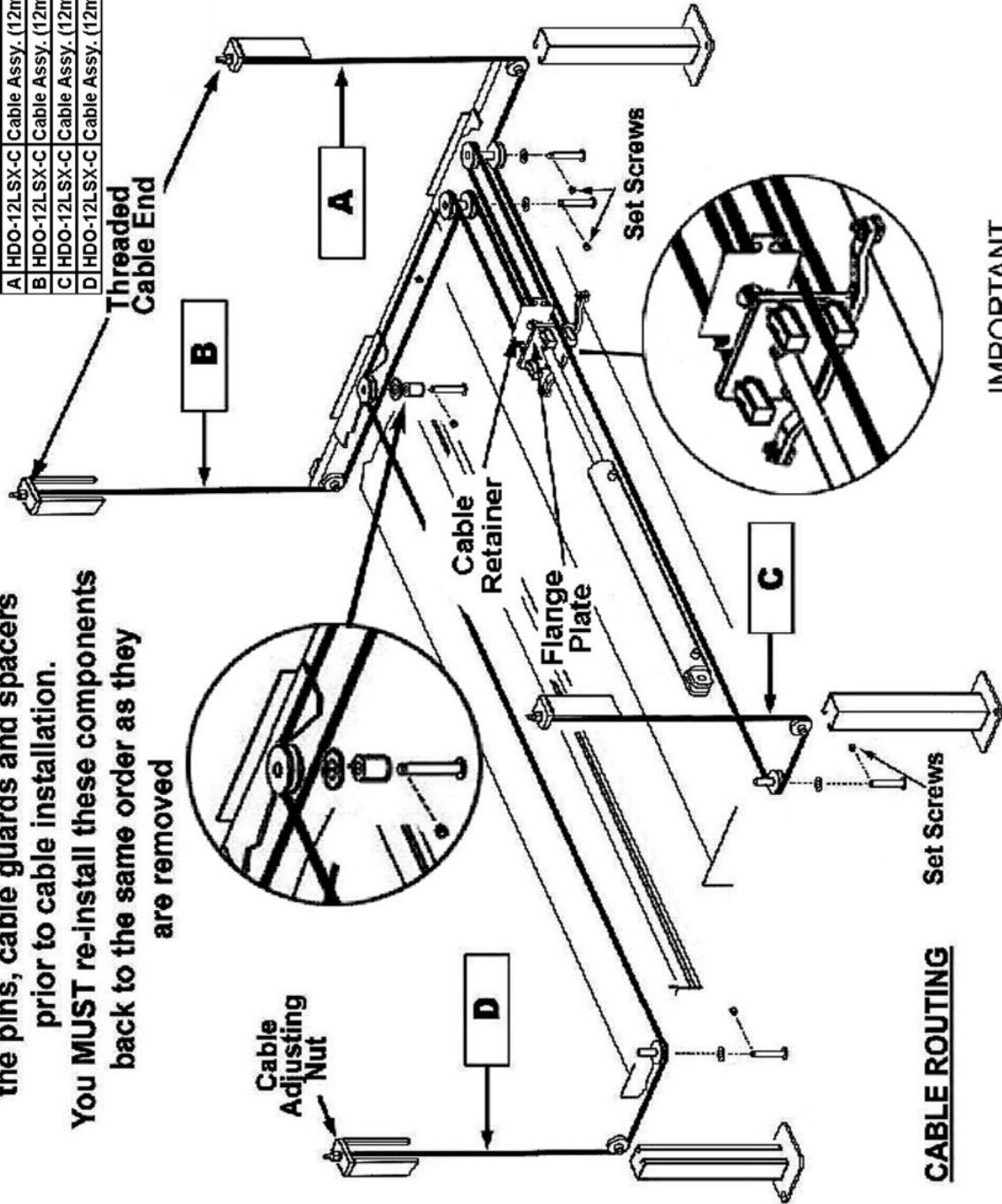

CAUTION!
 Tighten shaft set screws securely after routing cables. Failure to do so may result in injury or damage to lift.

CABLE ROUTING

IMPORTANT
 Install Flange Plate, Cable Retainer and Guide As shown.

Fig. 7.2

STEP 8

(Cable / Sheave Installation)

1. Inspect Cables to insure proper lengths. All Cables should have ID tags showing proper Cable lengths.
2. In order to install the Cables it is necessary to first extend the Hydraulic Cylinder. Remove both Cylinder port plugs then use an air gun or come-along to extend the Cylinder.

IMPORTANT! - Be careful not to damage the chrome rod during this step. (See Fig. 8.1)

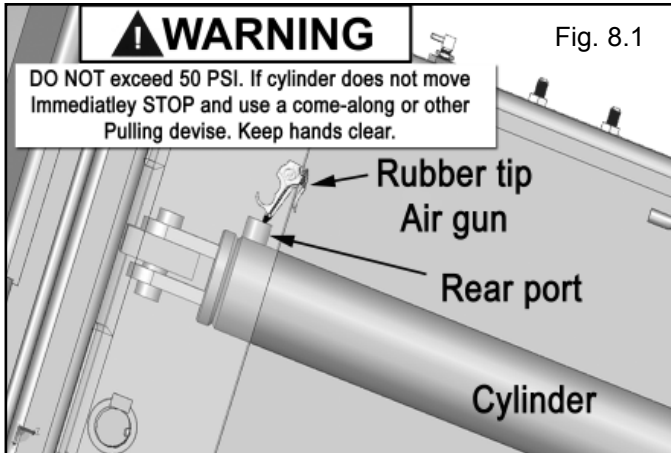

3. You must reinstall the Sheaves, Spacers and Pins in the same order as they are removed. (See Fig. 8.2)

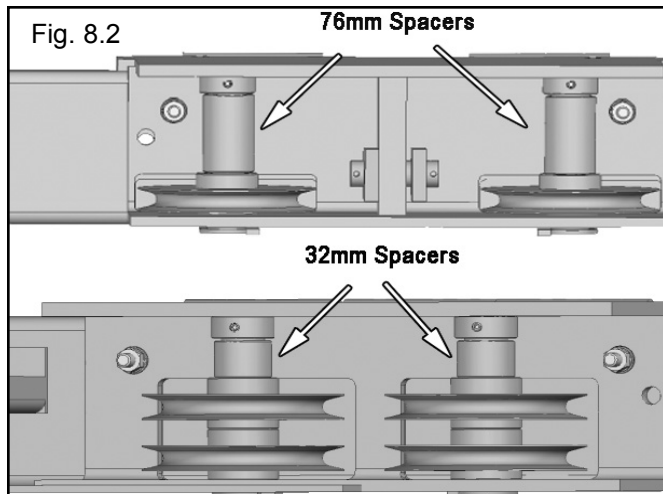

DANGER!

DO NOT PROCEED unless visual confirmation is made of ALL safety locks. ALL locks MUST be engaged before proceeding. Failure to comply with these instructions may result in severe personal injury or death. (See page 11)

STEP 9

(Cable Installation)



DANGER!

Failure to route lifting cables as described may lead to serious personal injury and/or death to operator or bystander and/or may cause damage to property.



WARNING!

WHEN THE CABLE ADJUSTING NUTS BOTTOM OUT ON THE THREADED END OF THE CABLE CONNECTOR AND THERE IS STILL SLACK IN THE CABLES, THE CABLES HAVE STRETCHED BEYOND THE SAFE USEFUL LENGTH AND NEED TO BE REPLACED WITH FACTORY APPROVED CABLE ASSEMBLIES. DO NOT PLACE WASHERS, SPACERS OR OTHER DEVICES TO "SHORTEN" THE EFFECTIVE CABLE LENGTH AS DAMAGE TO THE LIFT OR INJURY TO PERSONS MAY OCCUR.

1. Make sure the Cylinder Flange Plate is installed with the guide assembly facing down and the Cylinder retainer plate on the outside of the guide. Lug ends of cables start at Cylinder. (See Fig. 9.1)

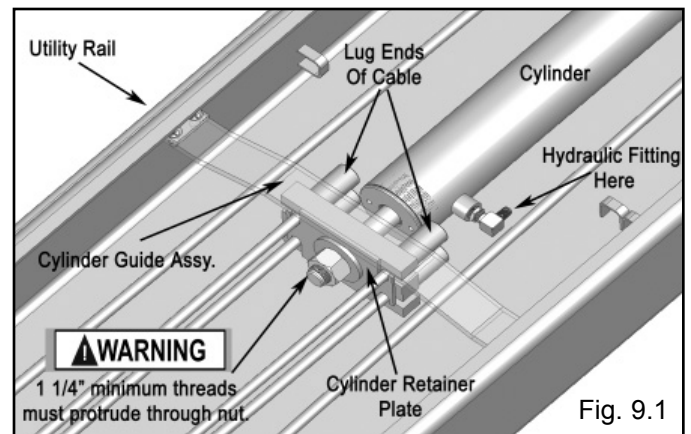

2. Route the threaded Cable ends through the ends of each Cross Tube, over the Slack Safety Sheave then to the top of each Column. Secure using the M22 Hex Head Nuts and Flat Washers. Tighten each nut until there is at least one inch of threads protruding through the top of the Nut. The Cables will remain loose until start up and final Cable adjustments are made. (See Fig. 9.2 - 9.3)

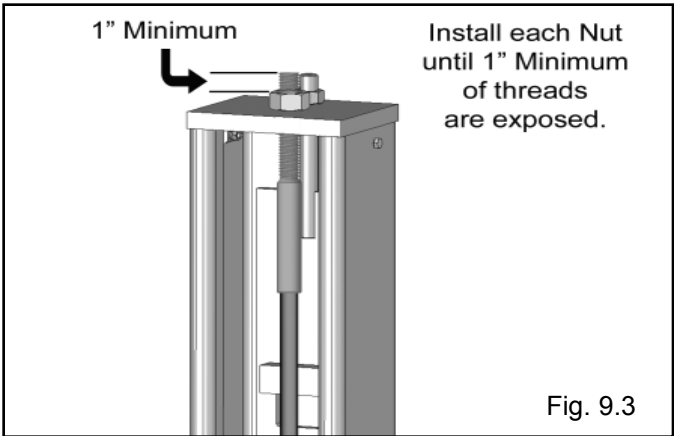
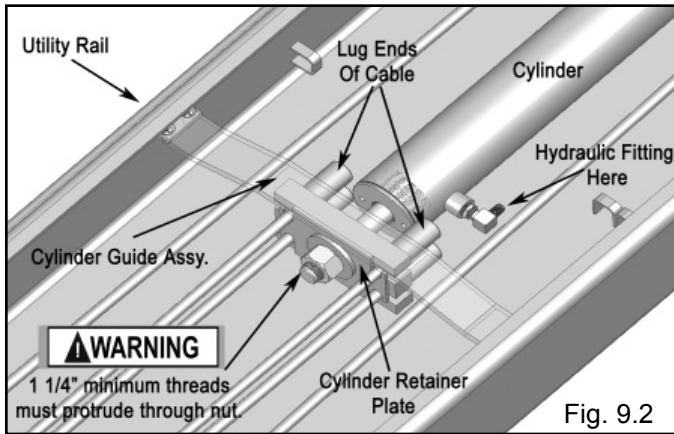

3. After routing the Cables double-check to make sure all are properly positioned and remain within the grooves of ALL Sheaves. (See Fig. 9.4 - 9.5)

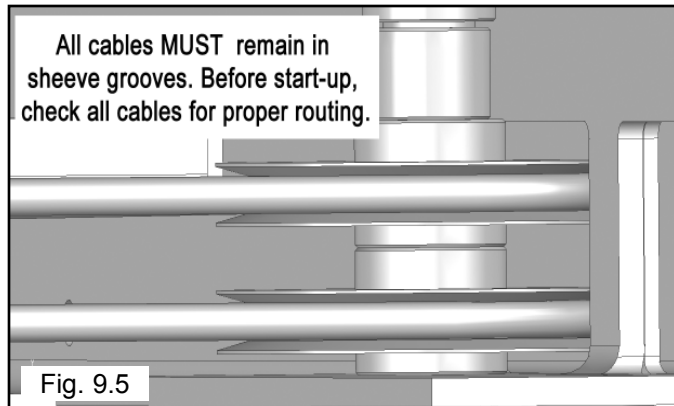
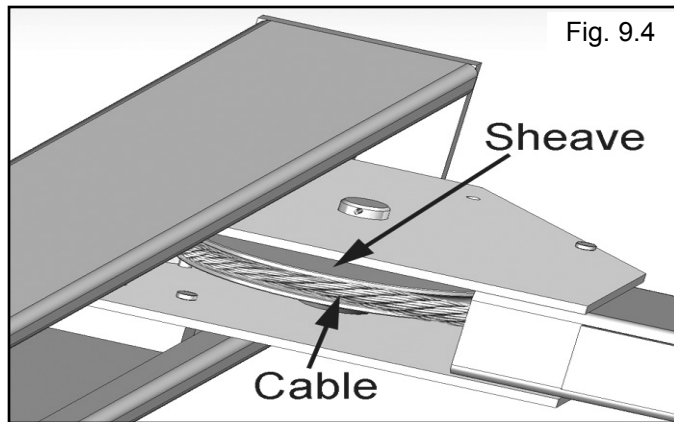

STEP 10

(Power Unit Installation)

1. Mount the Power Unit, Air Valve Mounting Bracket, Vibration Dampner, and Flex Tube Mounting Bracket to the Power Unit Mounting Bracket using the M8 Hex Bolts and Nylock Nuts, then fill the reservoir with 12 quarts of 10-WT hydraulic oil or Dexron III automatic transmission fluid. (See Fig. 10.1)

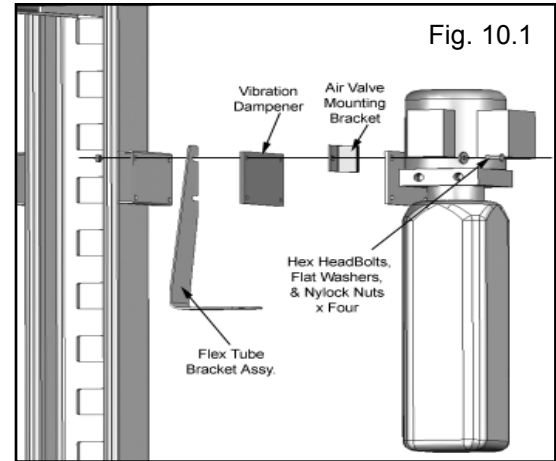

STEP 11

(Routing Hydraulic Hoses)

1. Remove the shipping plugs from both ports prior to installing the Fittings. (See Fig. 11.1)

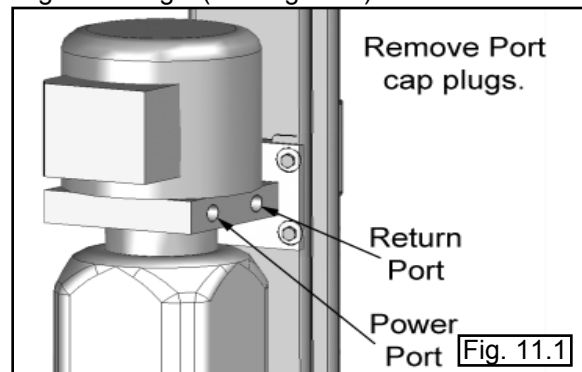

2. Install the two 90-degree Hydraulic Fittings, one to the POWER PORT and one to the RETURN PORT of the Power Unit. **(Port Location May Vary, Check the Power Unit documentation or contact Tech Support.)** (See Fig. 11.2)

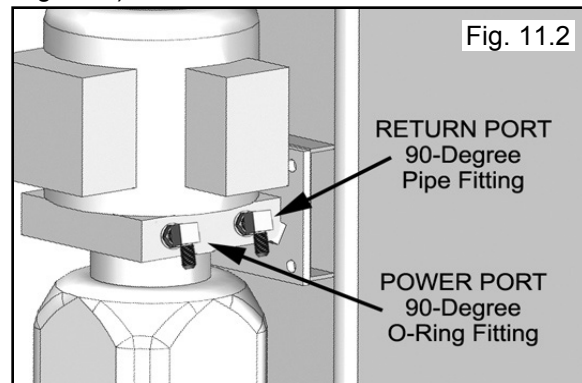

2. Install the 90-degree fitting on the Power Port. On the pipe thread side of the fitting it is recommended to use Teflon tape or pipe sealer. DO NOT USE TEFLON TAPE on the JIC flared end. (See Fig. 11.3)

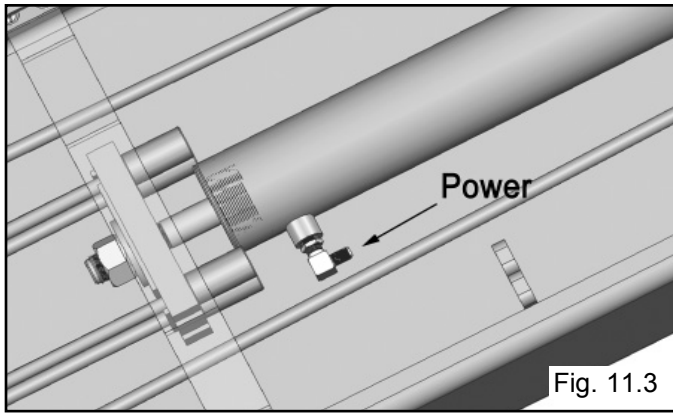

3. Install the 90° Fitting in the Return Port on the Cylinder. On the pipe thread side of the fitting it is recommended to use Teflon tape or pipe sealer. (See Fig. 11.4)

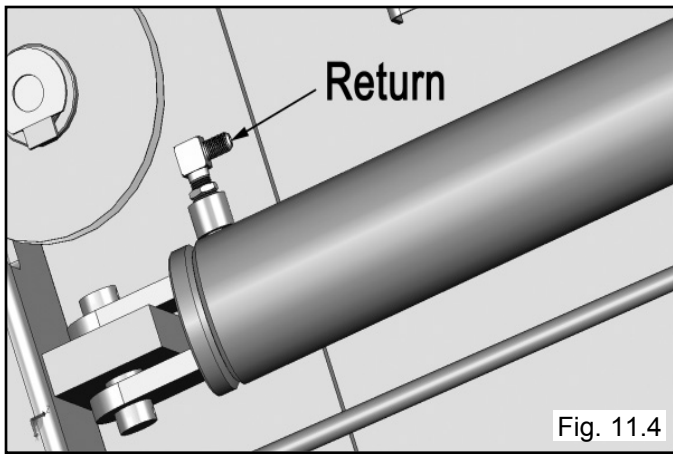

4. Install the Flex hose to the outside of the Powerside Runway adjacent to the Power Unit. Tighten securely. (See Fig. 11.5)

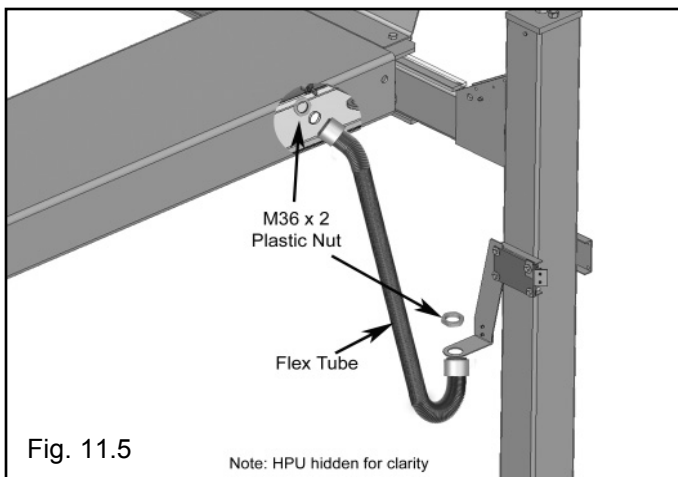

5. Run the Power and Return Hydraulic lines through the Flex Hose making sure to pass through the retaining rings. MAKE SURE HOSES ARE KEPT CLEAR OF CABLES. (See Fig. 11.6 - 11.8)

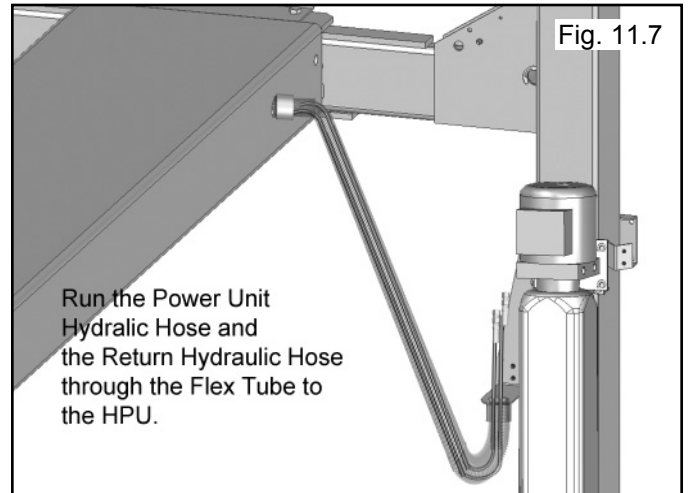
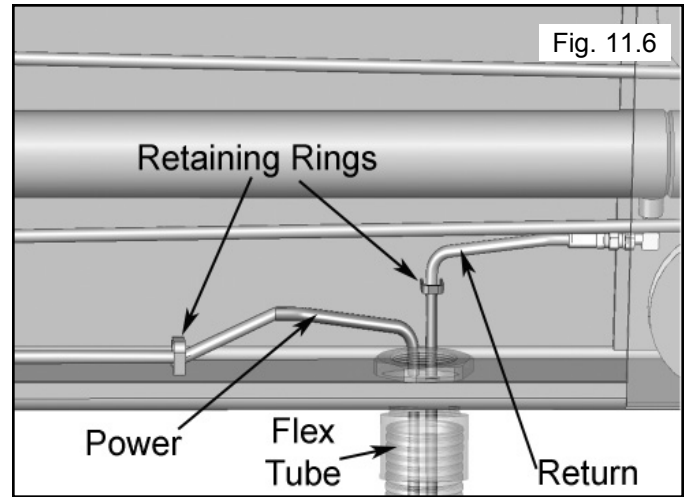

6. Connect the Power Unit Hydraulic Hose and the Return Hydraulic Hose to the appropriate fitting on the HPU. DO NOT use Teflon tape on the JIC Fittings. (See Fig. 11.8)

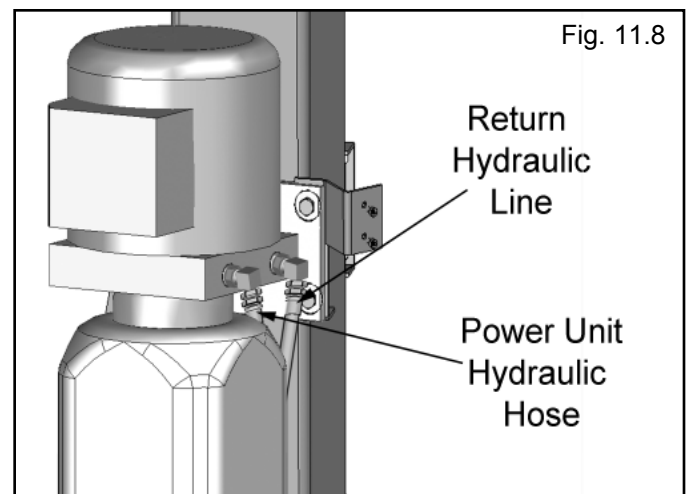

STEP 12

(Routing Air Lines)

Route the air line as shown below making sure to position the push button air valve with the INLET facing towards the AIR SOURCE and the OUTLET facing the direction of the LIFT.

A filter/regulator/lubricator must be installed on air supply at lift. Failure to do so will void the warranty. Cut the provided 1/4" air line tubing with a sharp blade to lengths as required. Tubing must be cut square with no burrs.

Note: To assemble air line tubing into fitting, use firm, manual pressure to push tubing into the fitting until it bottoms out. To remove air line tubing from the fitting, hold push sleeve in (against fitting) and, at the same time, pull out on tubing. Pay careful attention to keep air line clear of any pinch points. Improper assembly may result in safety lock failure.

AIR PRESSURE SHOULD BE REGULATED TO 125 PSI MAX. (See Fig. 12.1)

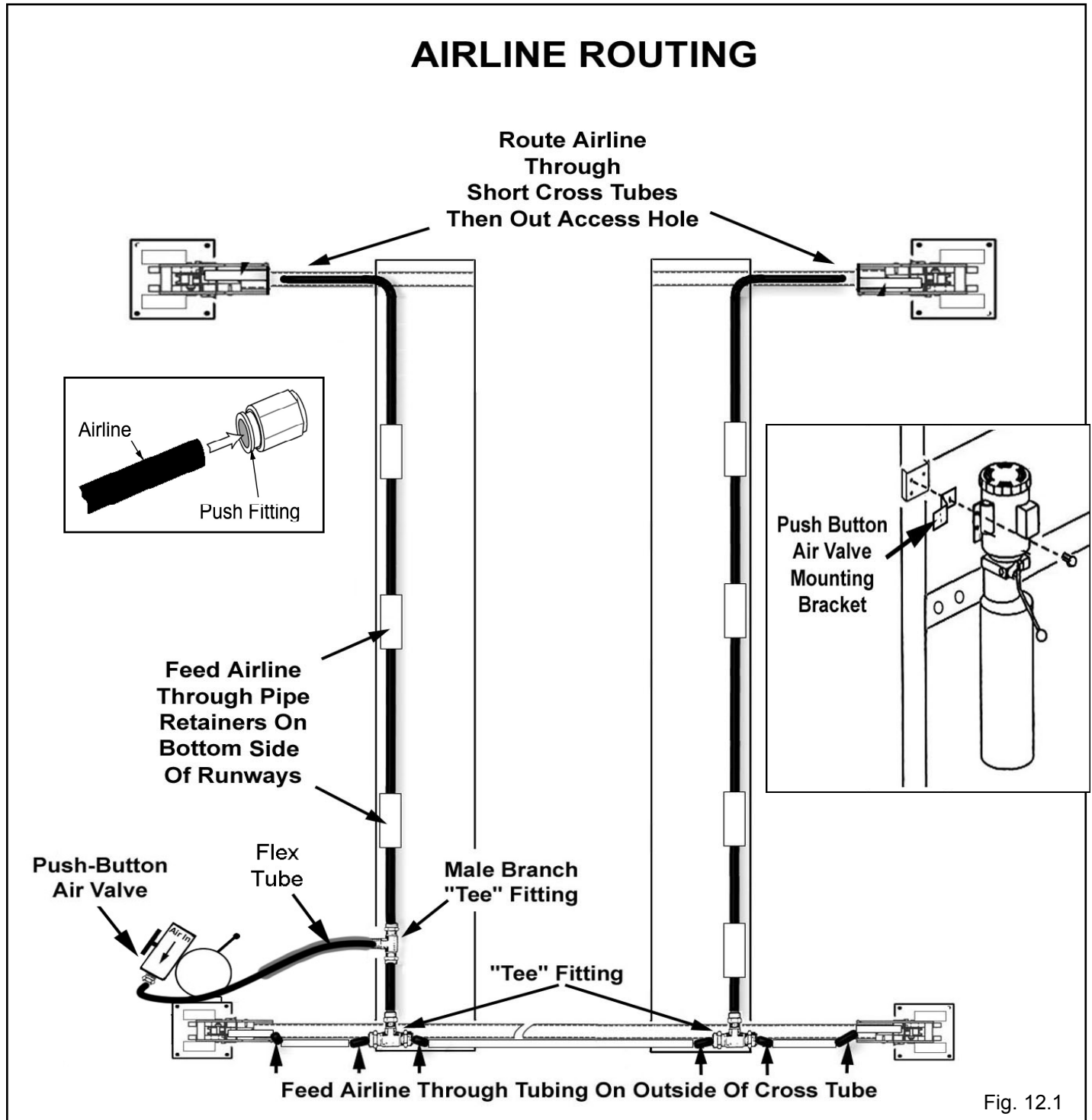

Fig. 12.1



DANGER!

DO NOT PERFORM ANY MAINTENANCE OR INSTALLATION OF ANY COMPONENTS WITH OUT FIRST ENSURING THAT ELECTRICAL POWER HAS BEEN DISCONNECTED AT THE SOURCE OR PANEL AND CANNOT BE RE-ENERGIZED UNTIL ALL MAINTENANCE AND/OR INSTALLATION PROCEDURES ARE COMPLETED.



IMPORTANT POWER-UNIT INSTALLATION NOTES

- DO NOT run power unit with no oil. Damage to pump can occur.
- The power unit must be kept dry. Damage to power unit caused by water or other liquids such as detergents, acid etc., is not covered under warranty.
- Improper electrical hook-up can damage motor and will not be covered under warranty.
- Motor can not run on 50HZ without a physical change in motor.
- Use a separate breaker for each power unit.
- Protect each circuit with time delay fuse or circuit breaker.
- For 208-230 volt, single phase, use a 25 amp fuse.
- For 208-230 volt, three phase, use a 20 amp fuse.
- For 380-440 volt, three phase, use a 15 amp fuse.

Installation and adjustment.

DO NOT attempt to raise vehicle until a thorough operation check has been completed.

All wiring must be performed by a certified electrician only.

Single Phase

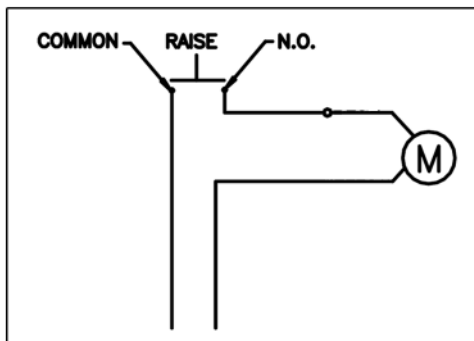

Three Phase

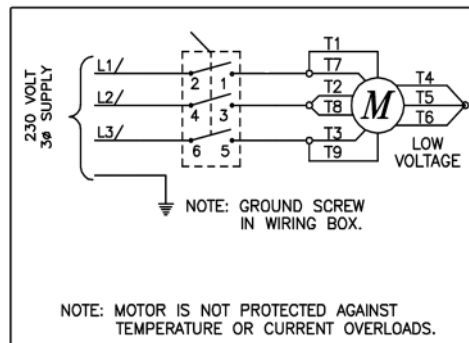

SEE WIRING INSTRUCTIONS AFFIXED TO MOTOR FOR PROPER WIRING INSTRUCTIONS.

Important Safety Label Placement Guidelines

Equipment: Four Post Lifts

Revised 06-05-08

⚠WARNING

THESE ANSI/ALI ALC-TV-2006 MANDATED SAFETY LABELS ARE PROVIDED FOR THIS PRODUCT FOR THE PROTECTION OF THE OPERATOR AND ANY PERSON(S) working near the lift. The safety stickers must be installed as per the instructions below prior to the completion of installation. Failure to properly install warning labels could fail to warn and lead to serious personal injury or death to operator or bystander or damage to property. Be sure everyone who operates this equipment understands all the information, caution, warning and danger labels. Keep the labels clean so they are legible. This applies to all caution, warning and danger labels. It is the OWNER'S RESPONSIBILITY to provide information to all operators for safe operation of this lift. Replace any damaged or worn labels. Once any part of a label becomes illegible, it should be replaced. The part numbers for the labels are located in the lower right corner of the label. Replacement labels may be ordered through your dealer or the address below. When installing and/or replacing labels, be sure the surface is clean and dry, peel the backing off the label, and apply to the reservoir as shown below. Be sure to wipe with a clean cloth to rub out all air bubbles

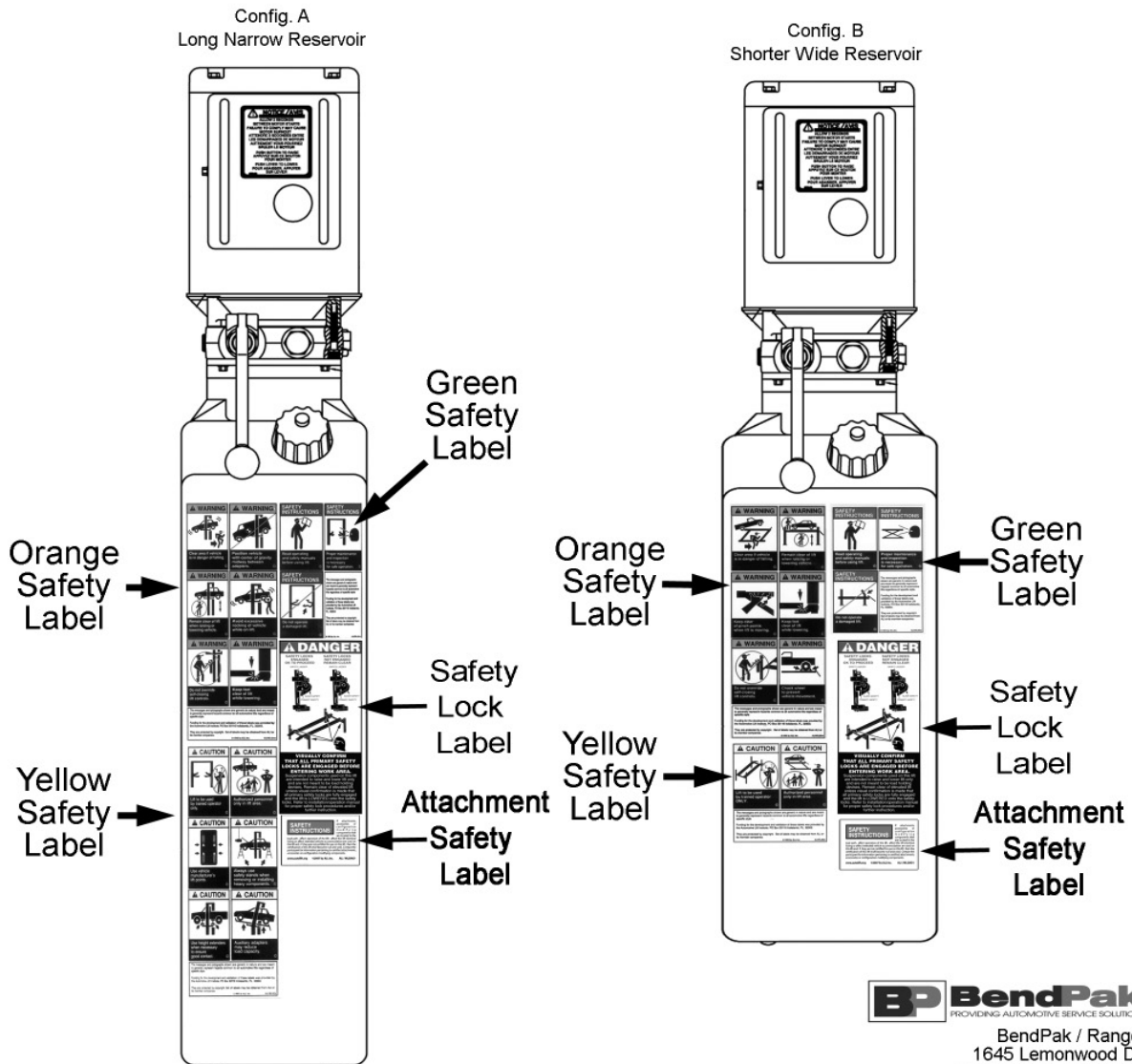

BendPak / Ranger
1645 Lemonwood Dr.
Santa Paula, CA 93060
Tel: 1-805-933-9970 / www.bendpak.com

STEP 13

(Power Unit Hook Up)

1. Have a certified electrician run the Power Supply to motor. Refer to the data plate found on the motor for proper power supply and wire size.



RISK OF EXPLOSION!

This equipment has internal arcing or parts that may spark and should not be exposed to flammable vapors. Motor should not be located in a recessed area or below floor level. NEVER expose motor to rain or other damp environments. DAMAGE TO MOTOR CAUSED BY WATER IS NOT COVERED UNDER WARRANTY.

IMPORTANT NOTE:

CAUTION Never operate the motor on line voltage less than 208V. Motor damage may occur which is not covered under warranty. Have a certified electrician run appropriate power supply to motor. Size wire for 25 amp circuit. See Motor Operating Data Table. IMPORTANT: Use separate circuit for each power unit. Protect each circuit with time delay fuse or circuit breaker. For single phase 208-230V, use 25 amp fuse. Three phase 208-240V, use 25 amp fuse. For three phase 400V and above, use 15 amp fuse. All wiring must comply with NEC and all local electrical codes.

Fig. 13.1

POWER UNIT

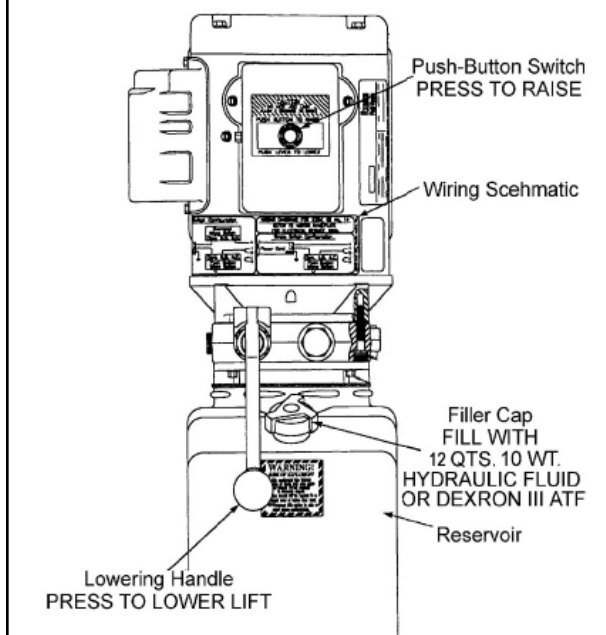

STEP 14

(Inspecting The Slack Safety Springs)



The following steps involve the SLACK CABLE SAFETY DEVICE and MAIN SAFETY. Failure to follow these steps could result in serious injury or death in the event of cable failure.

1. Inspect the ends of the SLACK SAFETY LOCK SPRINGS as shown. Make sure the spring ends are secure at both ends. **DO NOT ATTEMPT TO RAISE THE LIFT UNTIL THE SLACK SAFETY SPRINGS ARE ATTACHED AND THE ROLLERS ARE PULLED CLEAR FROM THE LADDER.** (See Fig. 14.1)

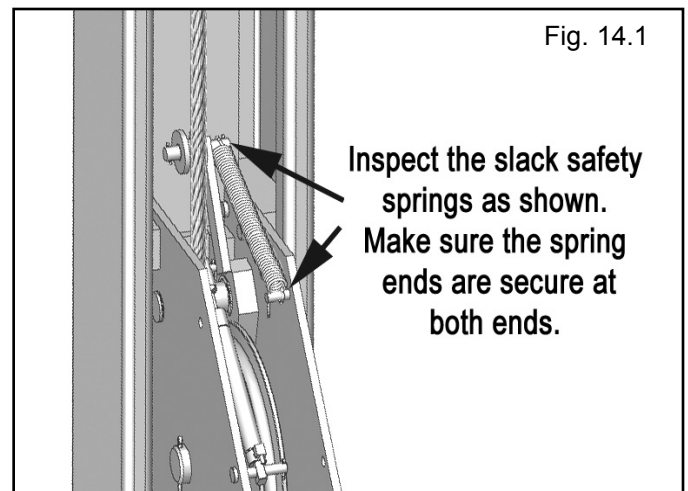

STEP 15

(Lift Start Up / Final Adjustments)

1. Make sure the Power Unit reservoir is full with 12 quarts of 10-WT hydraulic oil or Dexron-III automatic transmission fluid.
2. Spray the inside of the Columns where the Slide Blocks glide with a light lubricant or WD-40.
3. Test the Power Unit by pressing the push-button switch. If the motor sounds like it is operating properly, raise the lift and check all Hose Connections for leaks. If the motor gets hot or sounds peculiar, stop and check all electrical connections.
4. Before proceeding, double-check to make sure all Cables are properly positioned within the grooves of ALL Sheaves. Make sure all Cable Sheave retaining pins and/or clips are secure.

5. Check to make sure that all Slack Safety Locks are cleared and free. (See Fig. 15.1)

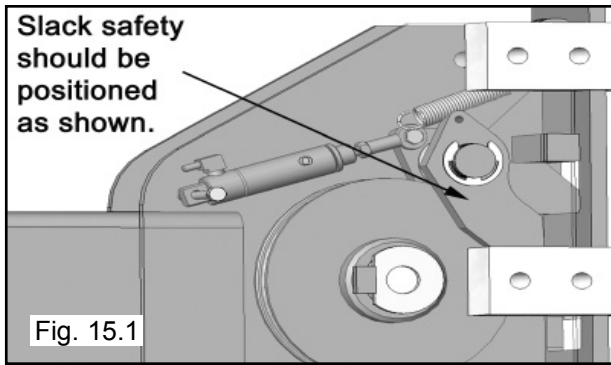

6. Continue pressing the raise button until the Cables get taugth and the lift starts to move.

7. RAISE LIFT UNTIL THE CYLINDER BOTTOMS OUT AND THE LIFT STOPS. ADJUST EACH CABLE SO THAT EACH SAFETY LOCK RESTS AT ONE INCH ABOVE THE TOP SAFETY LOCK POSITION. It may be necessary to tighten or loosen each Cable to reach the proper height. The Cable Nuts **MUST** be tightened until there is at least one inch of threads protruding through the nut. (See Fig. 15.2.)

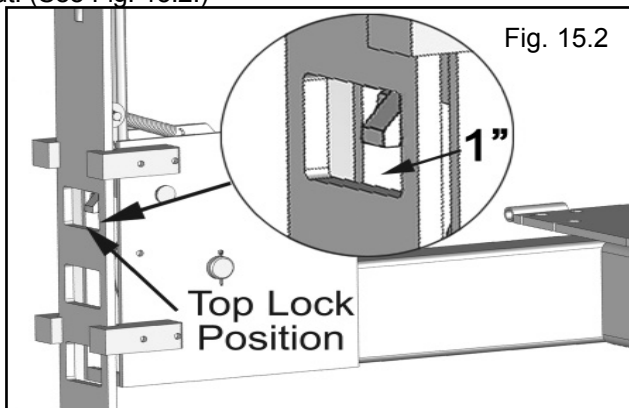

All Cable Nuts **MUST** be tightened on each end until there is at least one inch of threads protruding through the nut. Failure to do so could result in serious injury or death.

NOTE:

There will be initial stretching of the cables in the beginning and/or with increased loads. Adjust the Cables as outlined above a week after first use, then every three to six months thereafter depending on usage and/or to compensate for stretch.

8. After connecting the air supply, press the Push Button Air Valve and check that all Safety Locks are functioning properly. Lower the lift by pressing the Push Button Air Valve and Power Unit Lowering Valve simultaneously.



KEEP HANDS AND FEET CLEAR.

Remove hands and feet from any moving parts. Keep feet clear of lift when lowering. Avoid pinch points.

9. Check all MAIN SAFETY LOCKS to make sure they move freely and spring back to the lock position when released. Lubricate all SAFETY PIVOT points with WD-40 or equal.

10. Run the lift up and down a few times to insure that the locks are engaging uniformly and that the safety release mechanisms are functioning. Re-adjust if necessary.

STEP 16

(Attaching Approach Ramps/ Tire Stops)

1. Install the Approach Ramps on the entry side of the lift. (See Fig. 16.1 - 16.2)

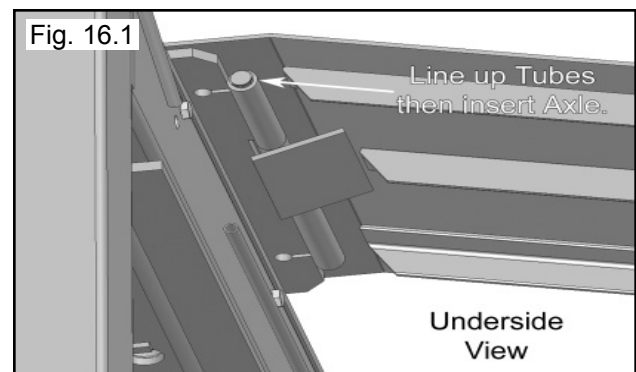
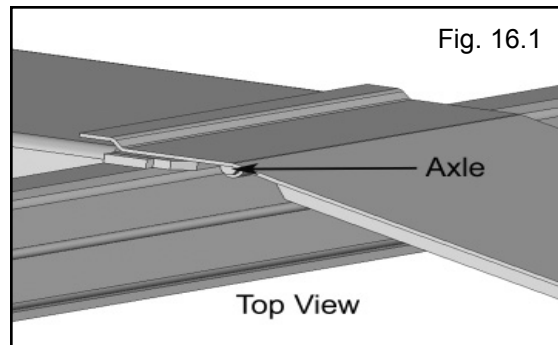

2. Install the Front Tire Stops at the forward side of the lift using the M14 x 2 Hex Bolts, Nuts and Washers. (See Fig. 16.3)

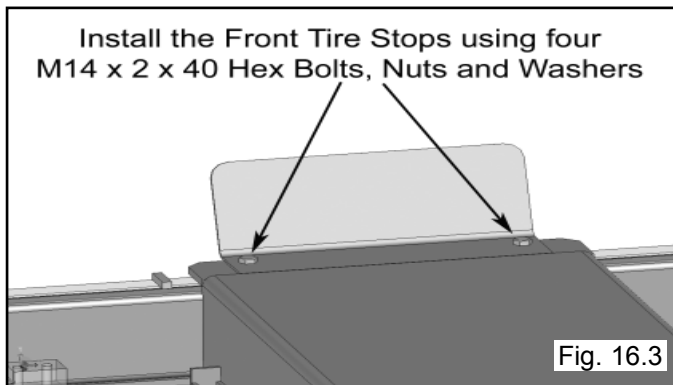

STEP 17

(Leveling / Synchronizing)

1. Using an engineer's automatic Level (transit), locate the Level, at a convenient location in the shop that allows an unobstructed view of all four corners of the runways.

2. Follow the Level manufacturer's instructions for proper setup of the Level. Be sure it is adjusted level in all directions.

3. Raise the lift approximately 30"- 40". Then lower the lift until all primary safeties are engaged in each column and the runways are completely resting on the primary safeties.

4. Place a Level target on the right/front corner of the runway. (See Fig. 17.1)

5. Beginning with "A" position, sight the level to the target and mark the number or the graduation on the inch scale of the target that aligns to the cross hairs of the Level, (See Fig. 17.1)

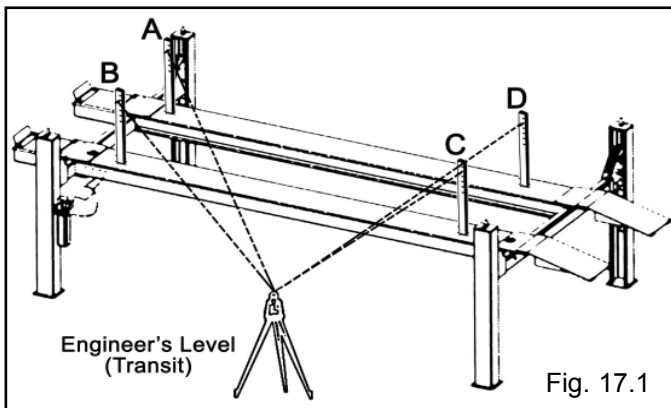

NOTE:

Use a pencil, marking pen or attach a paper clip onto the target scale at the crosshair reference.

6. Next, move the target and place it at point "B" on the runway. (See Fig. 17.1)

7. Rotate the Level and focus on the target scale.

8. Adjust the adjustment nut on the safety ladder bar at the top of the column at "B" until the crosshairs of the Level align to reference mark on the target scale. (See Fig. 17.1)

9. Repeat steps locating the target assembly at points "C" and "D" and adjusting safety ladders at each corresponding column until the reference mark on the target scale is on the crosshairs of the Level. The runways are now level at all four points. (See Fig. 17.1)

10. To complete the leveling procedures, lock each safety ladder jam nut tightly against bottom of column top plate. (See Fig. 17.2.)

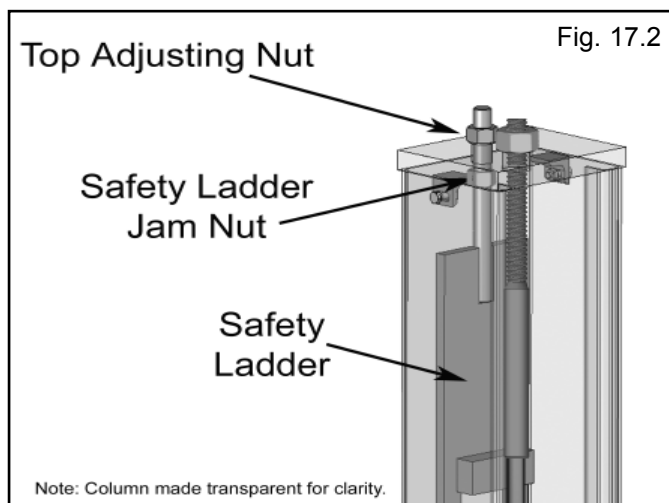

11. Next, load vehicle onto the lift.

12. Raise the lift to full height. Listen and watch as the primary safeties engage the safety ladder. Synchronize by adjusting the cables so that all four latches click at same time. Make necessary adjustments to the cables allowing compensation for stretch.



Safety Locks may not engage at exactly the same time when vehicles are being raised. They should be close.

Be sure that all four corners have passed the SAME Safety Ladder bar slot before lowering lift on the safety locks. NEVER lower lift on different Safety Lock position or damage to the lift may result.

STEP 18

(Bleeding)

1. Lift must be fully lowered before changing or adding fluid.
2. Raise and lower lift six times. The Cylinder is self bleeding. After bleeding system, fluid level in Power Unit reservoir may be down. Add more fluid if necessary to raise lift to full height. It is only necessary to add fluid to Raise lift to full height.
3. To pressure test, run lift to full rise and run the motor for approximately 3-seconds after lift stops. This will place pressure on the hydraulic system. Stop and check all fittings and hose connections. Tighten or reseal if required.

POST-INSTALLATION CHECK-OFF

- ◆ Columns Properly Shimmed And Stable
- ◆ Anchor Bolts Tightened
- ◆ Pivot / Sheave Pins Properly Attached
- ◆ Electric Power Supply Confirmed
- ◆ Cables Adjusted Properly
- ◆ Safety Locks Functioning Properly
- ◆ Check For Hydraulic Leaks
- ◆ Oil Level
- ◆ Lubrication of Critical Components
- ◆ Check For Overhead Obstructions
- ◆ Runways Level
- ◆ All Screws, Bolts, and Pins Secured
- ◆ Surrounding Area Clean
- ◆ Operation, Maintenance and Safety Manuals on Site

OPTIONAL EQUIPMENT INSTALLATION

Integrated Air Line Kit For Rolling Jacks

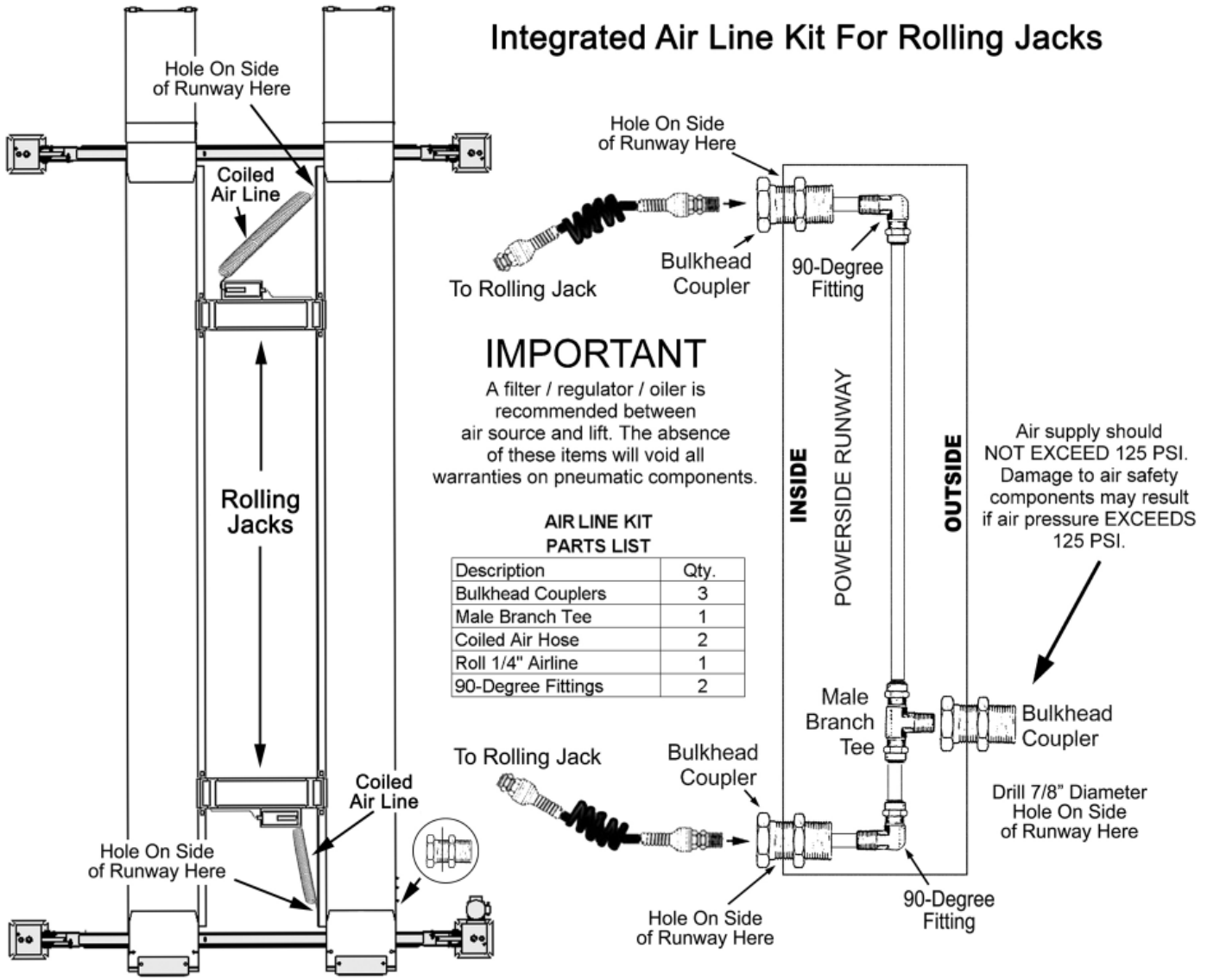

OPTIONAL EQUIPMENT INSTALLATION

Utility Air-Electric Workstation

Utility Station may be mounted on the vertical column of the lift or on a wall.

IMPORTANT: Check State or Local codes for any height requirements for the electrical outlets before mounting.

Adapter Plate Required for HD 9-12

To mount the Utility Station on a Lift Column, use the Box as a template, mark and drill 1 1/32" diameter holes. Use 5/16" diameter bolts and lock nuts to secure to the side of the lift.

IMPORTANT: The hole locations are critical to avoid interference with the carriage slide blocks.

For Wall mounting, mount in the same fashion, use appropriate hardware for either sheet rock or concrete.

IMPORTANT: All electrical wiring shall comply with all State and Local Codes.

Connect electrical wiring to single phase, 60Hz 115 volt electrical supply using suitable conduit (not supplied). The duplex receptacle must be connected through the GFCI with the input line to the box connected to a circuit breaker or time delay fuse rated at 20 amps. Both receptacles must be grounded to the box.

Connect main air supply to 1/4" ball valve inlet on the Utility Station (Run 1/2" line from compressor or main air system to Utility Station.)

Install Quick Couplers to the 1/4" male fittings on the box. The air supply between the filter and the lubricator will be non-lubricated, used for tire inflation or blowing off. The air outlet on the left side will be lubricated for air tool use.

Regulator Instructions

- Regulate pressure by raising the knob, then turning clockwise to increase and counterclockwise to decrease. Push knob down to lock setting.
- Adjust the oil mist using the screwdriver slot located on top of the lubricator.
- To fill the lubricator, first depressurize the air system, remove the slotted screw plug in the body. Replace the screw before repressurizing.

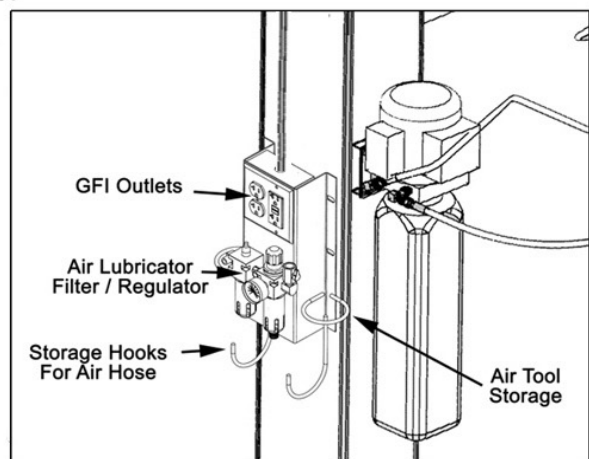
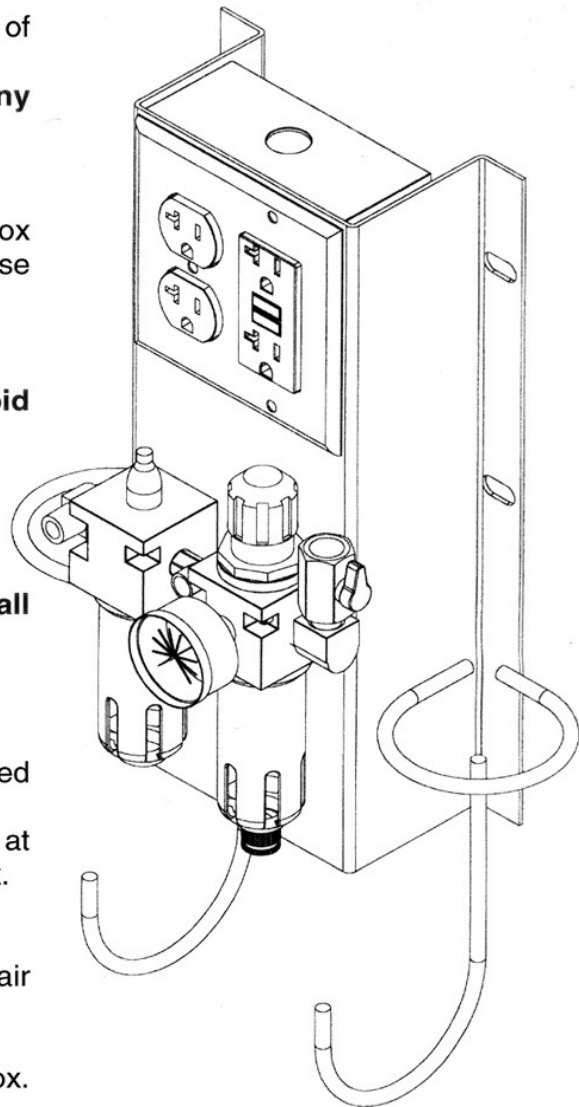

Adapter Plate Required for HD 9-12

STEP 19

(Operation)

To Raise Lift;

1. Position vehicle tires in the center of each Runway.
2. Set parking brake or use Wheel Chock to hold vehicle in position.
3. Before raising vehicle, be sure all personnel are clear of the lift and surrounding area. Pay careful attention to overhead clearances.
4. Raise the lift to the desired height by pressing the push button on the Power Unit.



VISUALLY CONFIRM THAT ALL PRIMARY SAFETY LOCKS ARE ENGAGED BEFORE ENTERING WORK AREA.

Suspension components on this lift are intended to raise and lower lift only and are not meant to be load holding devices. Remain clear of elevated lift unless visual confirmation is made that all primary Safety Locks are fully engaged and the lift is LOWERED onto the Safety Locks, Refer to installation /operation manual for proper safety lock procedures and /or further instruction.

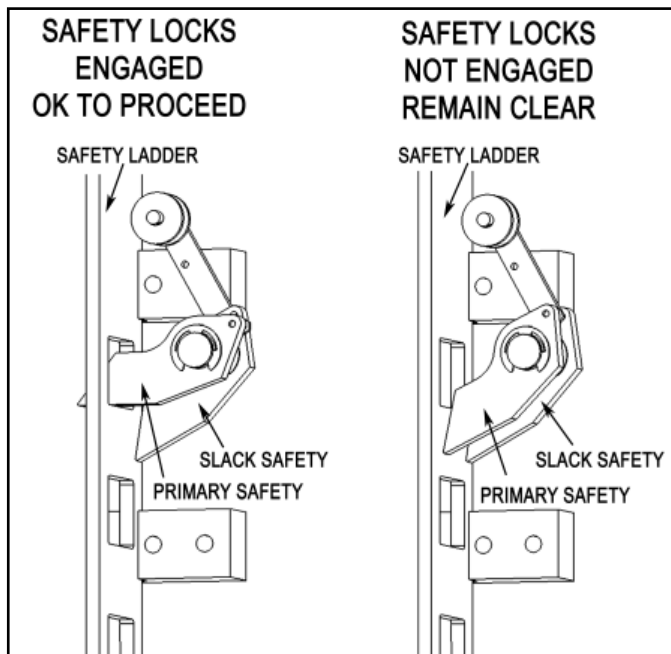

5. After vehicle is raised to the desired height, **lower the lift onto the nearest safety lock.** Do not allow cables to become slack. **ALWAYS INSURE ALL SAFETY LOCKS ARE ENGAGED** before entering work area.

To Lower Lift;

1. Before lowering vehicle, be sure all personnel are clear of the lift and surrounding area. Pay careful attention to overhead clearances. Insure all tools and equipment have been cleared from under the lift.
2. Raise the lift off of the Safety Locks by pressing the push button on the Power Unit. Make sure you raise the lift by at least two inches to allow adequate clearance for the locks to clear.
3. Press the Push Button Air Safety Valve and HOLD.
4. Push the LOWERING HANDLE on the power unit until the lift has descended completely.

When lowering the lift **PAY CAREFUL ATTENTION** that all personnel and objects are kept clear. **ALWAYS** keep a visual line of site on the lift **AT ALL TIMES.** **ALWAYS** make sure that all **FOUR LOCKS** are disengaged. If one of the locks inadvertently locks on descent the lift and/or vehicle may disrupt causing personal injury or death.

WEEKLY MAINTENANCE

1. Lubricate all rollers with general purpose oil or WD-40.
2. Check all cable connections, bolts and pins to insure proper mounting.
3. Lubricate safety lock pivot points with general purpose oil or WD-40.

MONTHLY MAINTENANCE

1. Check safety locks to insure they are in good operating condition.
2. Check all cables for excessive signs of wear.
3. Make a visual inspection of **ALL MOVING PARTS** and check for excessive signs of wear.
4. Replace **ALL FAULTY PARTS** before lift is put back into operation.



- ◆ **NEVER EXCEED THE RATED CAPACITY** of lift.
- ◆ **DO NOT USE LIFT** if any component is found to be defective or worn.
- ◆ **NEVER OPERATE LIFT** with any person or equipment below.
- ◆ **ALWAYS STAND CLEAR** of lift when lowering or raising.
- ◆ **ALWAYS INSURE SAFETY LOCKS ARE ENGAGED** before entering work area.
- ◆ **NEVER LEAVE LIFT IN ELEVATED CONDITION** unless all four safety locks are engaged.

⚠ WARNING

WIRE ROPE INSPECTION AND MAINTENANCE

- ◆ Lifting cables should be replaced every three - five years or when visible signs of damage are apparent. **DO NOT USE LIFT WITH DEFECTIVE / WORN CABLES.**
- ◆ Lifting cables should be maintained in a well-lubricated condition at all times. Wire rope is only fully protected when each wire strand is lubricated both internal and external. Excessive wear will shorten the life of the wire rope. The factory suggested wire rope lubricant that penetrates to the core of the rope and provides long-term lubrication between each individual strand is 90-WT gear oil or ALMASOL® Wire Rope Lubricant. In order to make sure that the inner layers of the rope remain well lubricated, lubrication should be carried out at intervals not exceeding three months during operation.
- ◆ All sheaves and guide rollers in contact with the moving rope should be given regular visual checks for surface wear and lubricated to make sure that they run freely. This operation should be carried out at appropriate intervals generally not exceeding three months during operation. For all sheave axles, the factory recommends standard wheel bearing grease. For all sheaves and/or guide rollers, the factory recommends 90-WT gear oil or similar heavy lubricant applied by any method including pump / spray dispensing, brush, hand and/or swabbing.

HOW OFTEN TO INSPECT

- ◆ Lifting cables should be visually inspected at least once each day when in use, as suggested by American Petroleum Institute (API) RP54 guidelines.
- ◆ Any lifting cables that have met the criteria for removal must be immediately replaced.

WHEN TO REPLACE LIFTING CABLES DUE TO BROKEN WIRES

- ◆ Lifting cables should be removed from service when you see six randomly distributed broken wires within any one lay length, or three broken wires in one strand within one lay length.

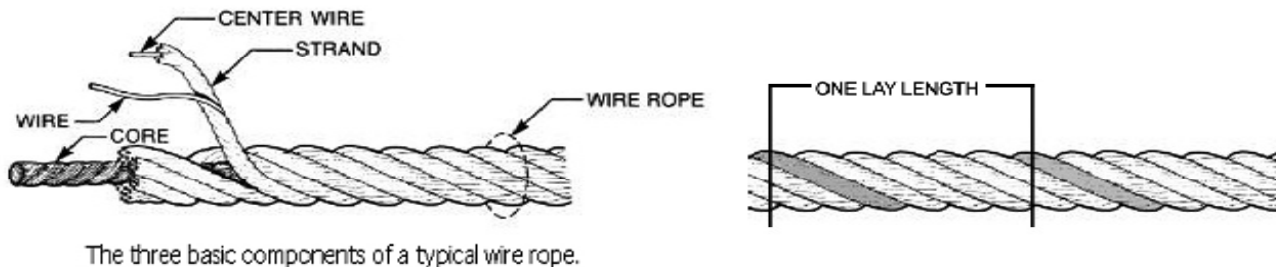

OTHER REASONS TO REPLACE LIFTING CABLES

- ◆ Corrosion that pits the wires and/or connectors.
- ◆ Evidence of kinking, crushing, cutting, bird-caging or a popped core.
- ◆ Wear that exceeds 10% of a wire's original diameter.
- ◆ Evidence of heat damage.

HOW TO FIND BROKEN WIRES

- ◆ The first step is to relax your rope to a stationary position and move the pick-up points off the sheaves. Clean the surface of the rope with a cloth — a wire brush, if necessary — so you can see any breaks.
- ◆ Flex the rope to expose any broken wires hidden in the valleys between the strands.
- ◆ Visually check for any broken wires. One way to check for crown breaks is to run a cloth along the rope to check for possible snags.
- ◆ With an awl, probe between wires and strands and lift any wires that appear loose. Evidence of internal broken wires may require a more extensive rope examination.

! WARNING

WIRE ROPE INSPECTION AND MAINTENANCE

- Lifting cables should be replaced every three years or when visible signs of damage are apparent. **DO NOT USE LIFT WITH DEFECTIVE: WORN CABLES.**
- Wire rope should be maintained in a well-lubricated condition at all times. Wire rope is only fully protected when each wire strand is lubricated both internally and externally. Excessive wear will shorten the life of the wire rope. The factory suggested wire rope lubricant that penetrates to the core of the rope and provides long term lubrication between each individual strand is AMSOIL Synthetic Open Gear and Wire Rope Compound or 90WT gear oil or similar heavy lubricant. In order to make sure that the inner layers of the rope remains well lubricated, lubrication should be carried out at intervals not exceeding three months during operation.
- All sheaves and guide rollers in contact with the moving rope should be given regular visual checks for surface wear and lubricated to make sure that they run freely. This operation should be carried out at appropriate intervals generally not exceeding three months during operation. For all sheave axles, the factory recommends standard wheel bearing grease. For all sheaves and /or guide rollers, the factory recommends 90 WT gear oil or similar heavy lubricant applied by any method including pump / spray dispensing, brush, hand and /or swabbing.

Failure to read, understand, and follow these instructions may cause death or serious injury.
Read and understand these instructions before using lift.

! DANGER

THE MAXIMUM LIFTING CAPACITY FOR THIS LIFT IS DESCRIBED BELOW

Maximum Lifting Capacity

12,000 Lbs. / 5443 Kg.

Maximum Lifting Capacity / Front Axle

6000 Lbs. / 2722 Kg.

Maximum Lifting Capacity / Rear Axle(s)

6000 Lbs. / 2722 Kg.

Exceeding the weight capacity of this lift can damage lift and/or property and may cause personal harm, injury or death to operators and/or bystanders. All vehicles MUST be positioned on lift with CENTER OF GRAVITY midway between adapters and/or centered on runways. Damage to lift due to overloading or misuse IS NOT covered under warranty.

⚠ WARNING

Clear area if vehicle is in danger of falling.

©

⚠ WARNING

Remain clear of lift when raising or lowering vehicle.

©

⚠ WARNING

Keep clear of pinch points when lift is moving.

©

⚠ WARNING

Keep feet clear of lift while lowering.

©

⚠ WARNING

Do not override self-closing lift controls.

©

⚠ WARNING

Chock wheel to prevent vehicle movement.

©

The messages and pictographs shown are generic in nature and are meant to generally represent hazards common to all automotive lifts regardless of specific style

Funding for the development and validation of these labels was provided by the Automotive Lift Institute, PO Box 33116 Indialantic, FL 32903.

They are protected by copyright. Set of labels may be obtained from ALI or its member companies

© 1992 by ALI, Inc. ALI/WL200w

SAFETY INSTRUCTIONS

Read operating and safety manuals before using lift.

©

SAFETY INSTRUCTIONS

Proper maintenance and inspection is necessary for safe operation.

©

SAFETY INSTRUCTIONS

Do not operate a damaged lift.

©

The messages and pictographs shown are generic in nature and are meant to generally represent hazards common to all automotive lifts regardless of specific style.

Funding for the development and validation of these labels was provided by the Automotive Lift Institute, PO Box 33116 Indialantic, FL 32903.

They are protected by copyright. Set of labels may be obtained from ALI or its member companies.

© 1992 by ALI, Inc. ALI/WL200s

⚠ CAUTION

Lift to be used by trained operator ONLY.

©

⚠ CAUTION

Authorized personnel only in lift area.

©

The messages and pictographs shown are generic in nature and are meant to generally represent hazards common to all automotive lifts regardless of specific style

Funding for the development and validation of these labels was provided by the Automotive Lift Institute, PO Box 33116 Indialantic, FL 32903.

They are protected by copyright. Set of labels may be obtained from ALI or its member companies

© 1992 by ALI, Inc. ALI/WL200c

Safe Lift Operation

Automotive and truck lifts are critical to the operation and profitability of your business. The safe use of this and other lifts in your shop is critical in preventing employee injuries and damage to customer's vehicles. By operating lifts safely you can insure that your shop is profitable, productive and safe.

Safe operation of automotive lifts requires that only trained employees should be allowed to use the lift.

TRAINING SHOULD INCLUDE, BUT NOT LIMITED TO:

- ◆ Proper positioning of the vehicle on the runway. (See manufacturers minimize wheel base loading requirements.)
- ◆ Use of the operating controls.
- ◆ Understanding the lift capacity.
- ◆ Proper use of jack stands or other load supporting devices.
- ◆ Proper use, understanding and visual identification of safety lock devices and their operation.
- ◆ Reviewing the safety rules.
- ◆ Proper housekeeping procedures (lift area should be free of grease, oil, tools, equipment, trash, and other debris.)
- ◆ A daily inspection of the lift should be completed prior to its use. Safety devices, operating controls, lift arms and other critical parts should be inspected prior to using the lift.
- ◆ All maintenance and repairs of the lift should be completed by following the manufacturer's requirements. Lift repair parts should meet or exceed OEM specifications. Repairs should only be completed by a qualified lift technician.
- ◆ The vehicle manufacturer's recommendations should be used for spotting and lifting the vehicle.

LIFT OPERATION SAFETY

- ◆ It is important that you know the load limit. Be careful that you do not overload the lift . If you are unsure what the load limit is, check the data plate found on one of the lift columns or contact the manufacturer.
- ◆ The center of gravity should be followed closely to what the manufacturer recommends.
- ◆ Always make sure you have proper overhead clearance. Additionally, check that attachments, (vehicle signs, campers, antennas, etc.) are not in the way.
- ◆ Be sure that prior to the vehicle being raised, the doors, trunk, and hood are closed securely
- ◆ Prior to being raised, make sure there is no one standing closer than six feet from the lift
- ◆ After positioning the vehicle on the lift runways, set the emergency brake, make sure the ignition is off, the doors are closed, overhead obstructions are cleared, and the transmission is in neutral.
- ◆ Double check that the automatic chock devices are in position and then when the lift is raised, observe the chocks
- ◆ Put pads or adapters in the right position under the contact points that have been recommended
- ◆ The lift should be raised just until the vehicle's wheels are about one foot off the ground. If contact with the vehicle is uneven or it appears that the vehicle is not sitting secure, carefully lower the lift and readjust.
- ◆ Always consider potential problems that might cause a vehicle to slip, i.e., heavy cargo, undercoating, etc.
- ◆ Pay attention when walking under a vehicle that is up on the hydraulic lift.



- ◆ **DO NOT** leave the controls while the lift is still in motion.
- ◆ **DO NOT** stand directly in front of the vehicle or in the bay when vehicle is being loaded or driven into position.
- ◆ **DO NOT** Go near vehicle or attempt to work on the vehicle when being raised or lowered.
- ◆ **REMAIN CLEAR** of lift when raising or lowering vehicle.
- ◆ **DO NOT** rock the vehicle while on the lift or remove any heavy component from vehicle that may cause excessive weight shift.
- ◆ **DO NOT** lower the vehicle until people, materials, and tools are clear
- ◆ **ALWAYS INSURE** that the safeties are engaged and lowered on to the safety ladders before any attempt is made to work on or near vehicle.
- ◆ Some vehicle maintenance and repair activities may cause the vehicle to shift. Follow the manufacturer's guidelines when performing these operations. The use of jack stands or alternate lift points may be required when completing some repairs.
- ◆ **READ AND UNDERSTAND** all safety warning procedures before operating lift.
- ◆ **KEEP HANDS AND FEET CLEAR.** Remove hands and feet from any moving parts. Keep feet clear of lift when lowering. Avoid pinch points.
- ◆ **ONLY TRAINED OPERATORS** should operate this lift. All non-trained personnel should be kept away from work area. Never let non-trained personnel come in contact with, or operate lift.
- ◆ **USE LIFT CORRECTLY.** Use lift in the proper manner. Never use lifting adapters other than what is approved by the manufacturer.
- ◆ **DO NOT** override self-closing lift controls.
- ◆ **CLEAR AREA** if vehicle is on danger of falling.
- ◆ **STAY ALERT.** Watch what you are doing. Use common sense. Be aware.
- ◆ **CHECK FOR DAMAGED PARTS.** Check for alignment of moving parts, breakage of parts or any condition that may affect its operation. Do not use lift if any component is broken or damaged.
- ◆ **NEVER** remove safety related components from the lift. Do not use lift if safety related components are damaged or missing.
- ◆ When the lift is being lowered, make sure everyone is standing at least six feet away.
- ◆ Be sure there are no jacks, tools, equipment, left under the lift before lowering.
- ◆ Always lower the vehicle down slowly and smoothly.

LIFT WILL NOT RAISE

POSSIBLE CAUSE

1. Air in oil, (1,2,8,13)
2. Cylinder binding, (9)
3. Cylinder leaks internally, (9)
4. Motor run backward under pressure, (11)
5. Lowering valve leaks, (3,4,6,10,11)
6. Motor runs backwards, (7,14,11)
7. Pump damaged, (10,11)
8. Pump won't prime, (1,8,13,14,3,12,10,11)
9. Relief valve leaks, (10,11)
10. Voltage to motor incorrect, (7,14,11)

REMEDY

1. Check for proper oil level.
2. Bleed cylinders.
3. Flush- Release valve to get rid of.
possible contamination
4. Dirty oil.
5. Tighten all fasteners.
6. Check for free movement of release.
7. Check motor is wired correctly.
8. Oil seal damaged or cocked
9. See Installation Manual
10. Replace with new part
11. Return unit for repair
12. Check pump-mounting bolts
13. Inlet screen clogged
14. Check wall outlet voltages and wiring

INSTRUCTION

- The oil level should be up to the bleed screw in the reservoir with the lift all the way down.
- See Installation Manual
- Hold release handle down and start unit allowing it to run for 15 seconds.
- Replace oil with clean Dexron ATF.
- Tighten fasteners to recommended torques.
- If handle does not move freely, replace bracket or handle assembly.
- Compare wiring of motor to electrical diagram on drawing.
- Replace oil seal around pump shaft.
- Consult Lift Manufacturer.
- Replace with new part.
- Return unit for repair.
- Bolts should be 15 to 18 ft. lbs.
- Clean inlet screen or replace.
- Make sure unit and wall outlet are wired properly.

MOTOR WILL NOT RUN

POSSIBLE CAUSE

1. Fuse blown, (5,2,1,3,4)
2. Limit switch burned out, (1,2,3,4)
3. Microswitch burned out, (1,2,3,4)
4. Motor burned out, (1,2,3,4,6)
5. Voltage to motor incorrect, (2,1,8)

REMEDY

- | REMEDY | INSTRUCTION |
|---|---|
| 1. Check for correct voltage | Compare supply voltage with voltage on motor nametag. Check that the wire is sized correctly. N.E.C. table 310-12 requires AWG 10 for 25 Amps. |
| 2. Check motor is wired correctly | Compare wiring of motor to electrical diagram on drawing. |
| 3. Don't use extension cords | According to N.E.C. : " The size of the conductors... should be such that the voltage drop would not exceed 3% to the farthest outlet for power..." Do not run motor at 115 VAC – damage to the motor will occur. |
| 4. Replace with new part | Replace with new part. |
| 5. Reset circuit breaker/fuse | Reset circuit breaker/fuse. |
| 6. Return unit for repair | Return unit for repair. |
| 7. See Installation Manual | See Installation Manual. |
| 8. Check wall outlet voltage and wiring | Make sure unit and wall outlet is wired properly. Motor must run at 208/230 VAC. |

LIFT LOWERS SLOWLY OR NOT AT ALL

POSSIBLE CAUSE

1. Cylinders binding, (1)
2. Release valve clogged, (5,4,2,3)
3. Pressure fitting too long, (6)

REMEDY

- | REMEDY | INSTRUCTION |
|---|--|
| 1. See Installation Manual | Consult Lift Manufacturer. |
| 2. Replace with new part | Replace with new part. |
| 3. Return for repair | Return for repair. |
| 4. Check oil. | Use clean 10-WT hydraulic oil or Dexron-III automatic transmission fluid only. If ATF is contaminated, replace with clean ATF and clean entire system. |
| 5. Clean release valve | Wash release valve in solvent and blow out with air. |
| 6. Replace fitting with short thread lead | Replace fitting with short thread lead. |

WILL NOT RAISE LOADED LIFT

POSSIBLE CAUSE

1. Air in oil, (1,2,3,4)
2. Cylinder binding, (5)
3. Cylinder leaks internally, (5)
4. Lift overloaded, (6,5)
5. Lowering valve leaks, (7,8,1,5,9)
6. Motor runs backwards, (10,12,9)
7. Pump damaged, (5,9)
8. Pump won't prime, (1,2,3,4,5,11,9)
9. Relief valve leaks, (8,5,9)
10. Voltage to motor incorrect, (10,12,5)

REMEDY

- | REMEDY | INSTRUCTION |
|--|--|
| 1. Check oil level | The oil level should be up to the bleed screw in the reservoir [with the lift all the way down.] |
| 2. Check/Tighten inlet tubes | Replace inlet hose assembly. |
| 3. Oil seal damaged or cocked | Replace oil seal and install. |
| 4. Bleed cylinders | See Installation Manual. |
| 5. See Installation Manual | Consult Lift Manufacturer. |
| 6. Check vehicle weight | Compare weight of vehicle to weight limit of the lift. |
| 7. Flush release valve | Hold release handle down and start unit allowing it to run for 15 seconds. |
| 8. Replace with new part | Replace with new part. |
| 9. Return unit for repair | Return unit for repair. |
| 10. Check motor is wired correctly | Compare wiring of motor to electrical diagram on power unit drawing. |
| 11. Inlet screen clogged | Clean inlet screen or replace. |
| 12. Check wall outlet voltage and wiring | Make sure unit and wall outlet is wired properly. |

LIFT WILL NOT STAY UP

POSSIBLE CAUSE

1. Air in oil, (1,2,3)
2. Check valve leaks, (6)
3. Cylinders leak internally, (7)
4. Lowering valve leaks, (4,5,1,7,6)
5. Leaking fittings, (8)

REMEDY

1. Check oil level The oil level should be up to the bleed screw in the reservoir with the lift all the way down.
2. Oil seal damaged and cocked Replace oil seal around pump shaft.
3. Bleed cylinder Refer to Installation Manual.
4. Flush release valve Hold release handle down and start unit allowing it to run for 15 seconds.
5. Replace with new valve Replace with new valve.
6. Return unit for repair Return unit for repair.
7. See Installation Manual Consult Lift Manufacturer.
8. Check complete hydraulic system for leaks. Tighten all hydraulics fittings and inspect all hoses.

INSTRUCTION

Model	Equalizer Cables (Note: Cables are Model Specific)	Part No.	Qty
A	HDO-12LXC Cable Assy. (12mm x 3,404mm) ST (M22 x 2.5) Cable "A"	5595780	1
B	HDO-12LXC Cable Assy. (12mm x 5,017mm) ST (M22 x 2.5) Cable "B"	5595781	1
C	HDO-12LXC Cable Assy. (12mm x 8,115mm) ST (M22 x 2.5) Cable "C"	5595794	1
D	HDO-12LXC Cable Assy. (12mm x 9,614mm) ST (M22 x 2.5) Cable "D"	5595795	1
A	HDO-12LSX-C Cable Assy. (12mm x 4,013mm) ST (M22 x 2.5) Cable "A"	5595784	1
B	HDO-12LSX-C Cable Assy. (12mm x 5,601mm) ST (M22 x 2.5) Cable "B"	5595785	1
C	HDO-12LSX-C Cable Assy. (12mm x 9,335mm) ST (M22 x 2.5) Cable "C"	5595798	1
D	HDO-12LSX-C Cable Assy. (12mm x 10,833mm) ST (M22 x 2.5) Cable "D"	5595799	1

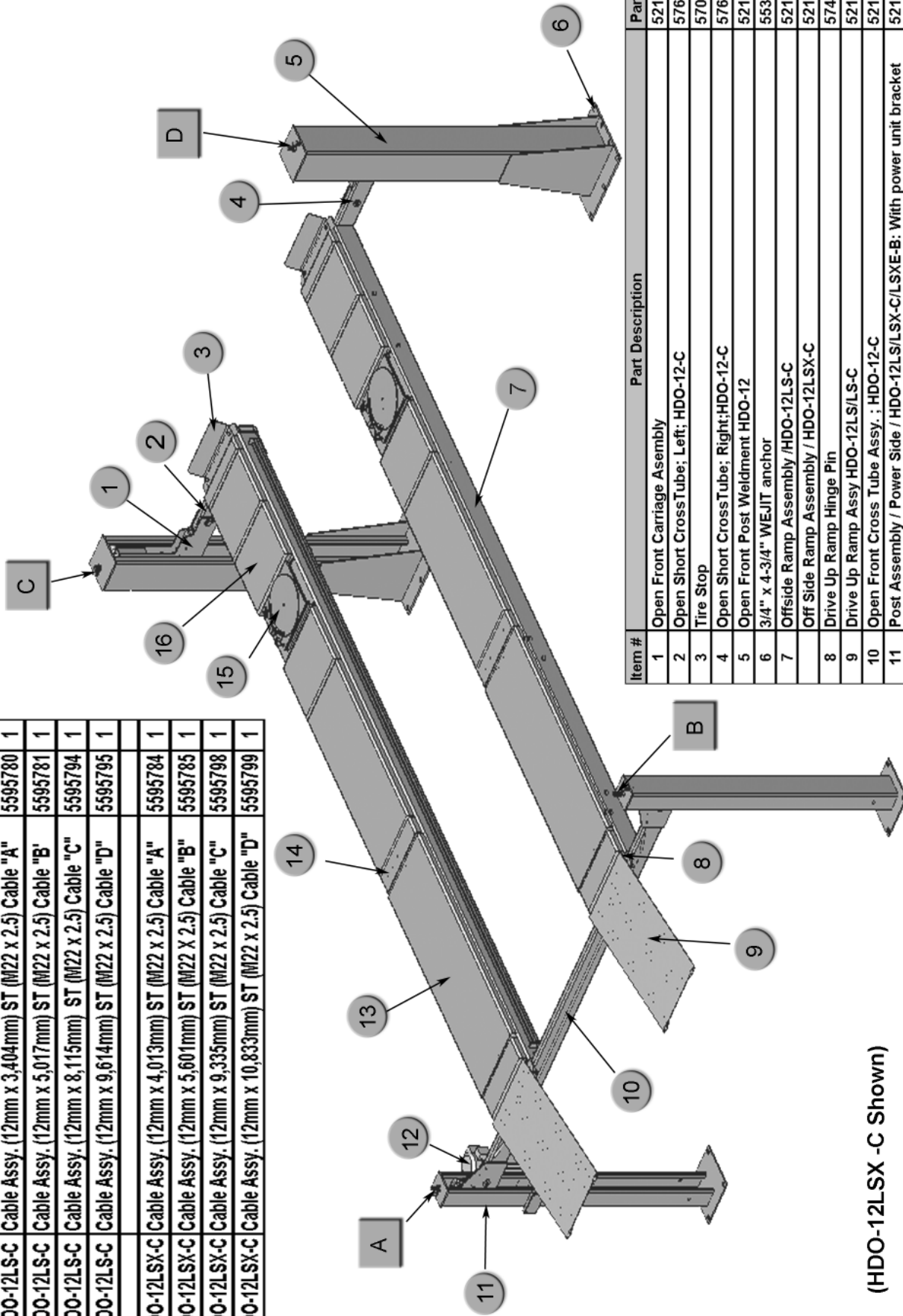

(HDO-12LSX -C Shown)

Item #	Part Description	Part No.	Qty
Not Shown	Power Unit Fitting / 1/4" 90 Degree w/O-Ring Fitting / Pressure	5550103	1

Item #	Part Description	Part No.	Qty
1	Open Front Carriage Assembly	5210354	2
2	Open Short CrossTube; Left; HDO-12-C	5766130	1
3	Tire Stop	5700630	2
4	Open Short CrossTube; Right; HDO-12-C	5766135	1
5	Open Front Post Weldment HDO-12	5210783	2
6	3/4" x 4-3/4" WEJIT anchor	5530455	4
7	Offside Ramp Assembly /HDO-12LS-C	5210348	1
8	Off Side Ramp Assembly / HDO-12LSX-C	5210349	1
9	Drive Up Ramp Hinge Pin	5745335	2
10	Drive Up Ramp Assy HDO-12LS/LS-C	5210842	2
11	Open Front Cross Tube Assy. : HDO-12-C	5210355	1
12	Post Assembly / Power Side / HDO-12LS/LSX-C/LSXE-B: With power unit bracket	5210795	1
13	Power Unit Complete / 220 Volt 60HZ, 1 Phase / AB-1466 SPX	5585079	1
14	Short Slip Plate (508mm x 1219mm) (HDO-12LS; LSX 2ea) (HD-12LSXE 4ea)	5700118	1
15	Power Side Ramp Assembly / HDO-12LS-C	5210342	1
16	Power Side Ramp Assembly / HDO-12LSX-C	5210343	1
15	Turn Plate Assembly (Set of two)	5210437	1
16	Movable Riser (482mm x 406MM) (HD-12LS; LSX 2ea) (HD-12LSXE 4ea)	5700210	1

Runway Parts List

Item #	Part Description	Part No.	Qty
1	Long Cylinder Hose / 1/4" x " / HDO12LS-B		1
1	Long Cylinder Hose / 1/4" x " / HDO-12LSX-B		1
2	1/4" O.D. Tube; TEE; Push to Connect	5550489	2
3	Flex Hose		1
4	Plastic Nut	5545540	2
5
6	Short Cylinder Hose / 1/4" x " / HDO-12LS-B		1
7	Short Cylinder Hose / 1/4" x " / HDO-12LSX-B		1
6	Ramp Sheave Roller / HD-12's / All Standard	5575390	6
8	HSSS, M8 x 1.25mm x 12mm; Hex Socket Screw	5530113	4
9	Roller Axle Pin / HD-12's / All Standard	5505675	4
10	3/8 NPT 90°/4SAE Cylinder fittings	5550106	3
11	Hairpin 28 diameter	5505115	2
12	Spacer, 82mm x 46mm x 39mm All HD-12/ HDO	5755658	2
13	1x 3 1/2" Cylinder Pin	5505695	1
14	3 x 70 Cylinder / HD-12's	5502165	1
15	Cylinder Flange Arm. Assy./ HD	5210986	1
16	1"-14 NYLOCK NUT	5535130	1
17	1" FLAT WASHER	5545165	1
18	Cable Retainer Plate	5731311	1
19	Spacer 38mm x 46mm x 39mm All HD-12/ HDO	5755680	2

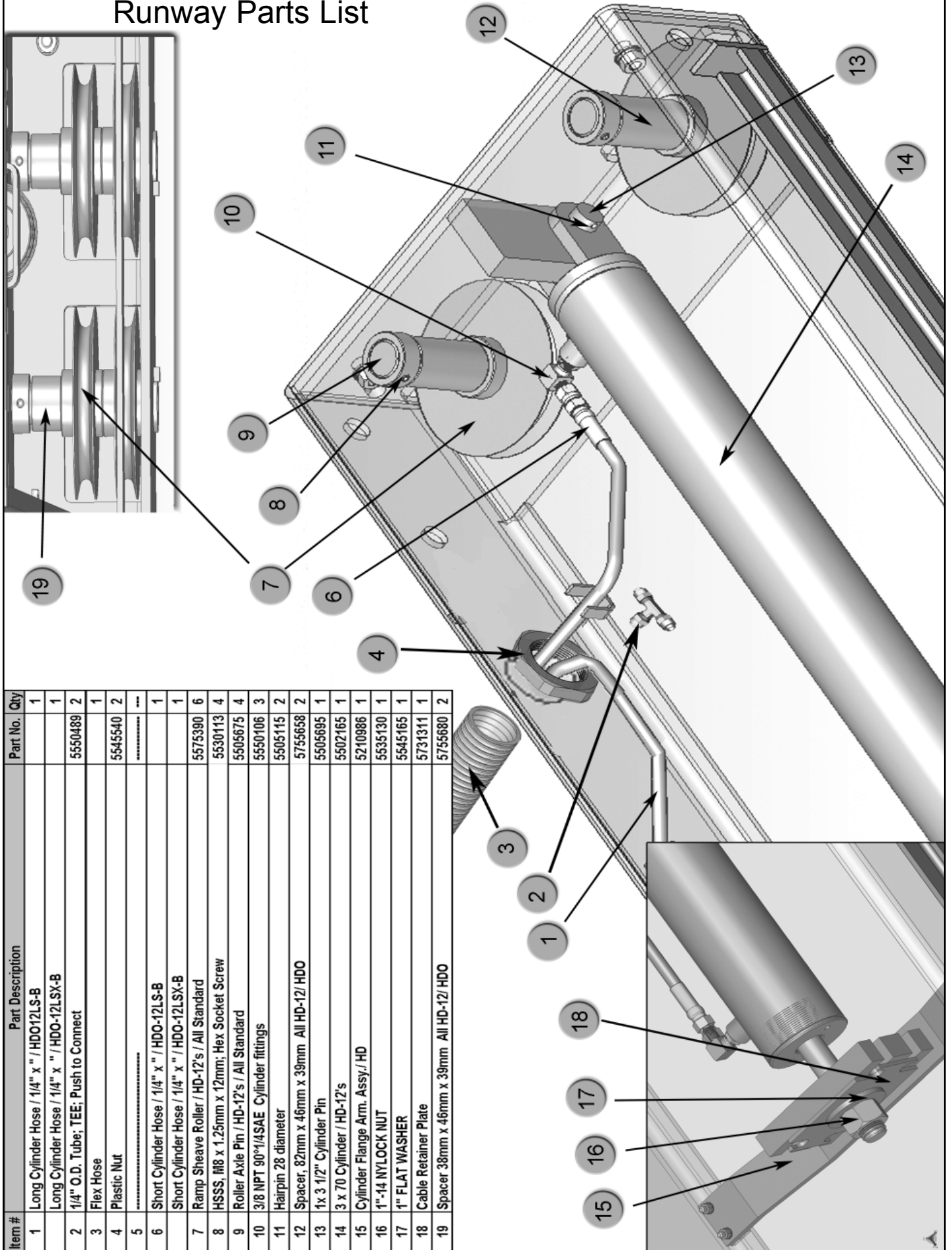

Item #	Part Description	Part No.	Qty
1	7/8-14 NYLOCK NUT; Cable Nut	5535149	4
2	Post Top Plate/HD Series	5210815	4
3	HD-9-B; HD-12-B Slack Safety sheave B SERIES	5575423	4
4	Cotter Pin; 3mm X 20mm; for slack safety sheave	5505416	4
5	HD-9-B; HD-12-B; Slack safety #2; Crosstube; B SERIES	5210000	4
6	HD-9-B; HD-12-B; Slack safety spring; B SERIES	5540277	4
7	HHB M 6 X 1 X 25	5210001	4
8	Air Cylinder Head	5502194	4
9	Air Safety Cylinder	5502195	4
10	1/4 Tube To 1/8 NPT 90° Push To Connect	5550481	4
11	HN M 6 X 1.0; Air Safety Mounting Nut	5535112	4
12	HHB M 6 X 1 X 7.5; Air Safety Mounting Bolt	5535357	4
13	Flat Washer; M 6; Air Safety Mounting; Washer	5545339	4
14	Set of two spacer tubes	5715366	4
15	1/4" Roll Of Poly-Flo Tubing	5570795	1
16	Crosstube Roller Pin HD-12's / All Standard	5505690	4
17	33MM Flat Washer / Crosstube	5545539	4
18	Cotter Pin; 5mm X 40mm; Crosstube Pulley pin	5545417	4
19	Crosstube Roller / HD-12's / All Standard	5575385	4
20	HD-9-B; HD-12-B; Safety # 1 B SERIES	5210001	4
21	25mm E-Ring 1"; for Safeties	5540275	16
22	Safety Pin	5505670	4
23	Slide blocks; HD-12-B;	5716151	16
24	Travel post ladder, HD-9B; 12B; 14 WINDOW CUTS; 84" H	5306778	4
25	Nylock Nut M 10 X 1.5 Top Plate Nut	5535340	4
26	M12 X 1.75 Nuts; Ladder Nuts	5535354	8
27	HB M 10 X 1.5 X 50; Top Plate Bolt	5530759	4

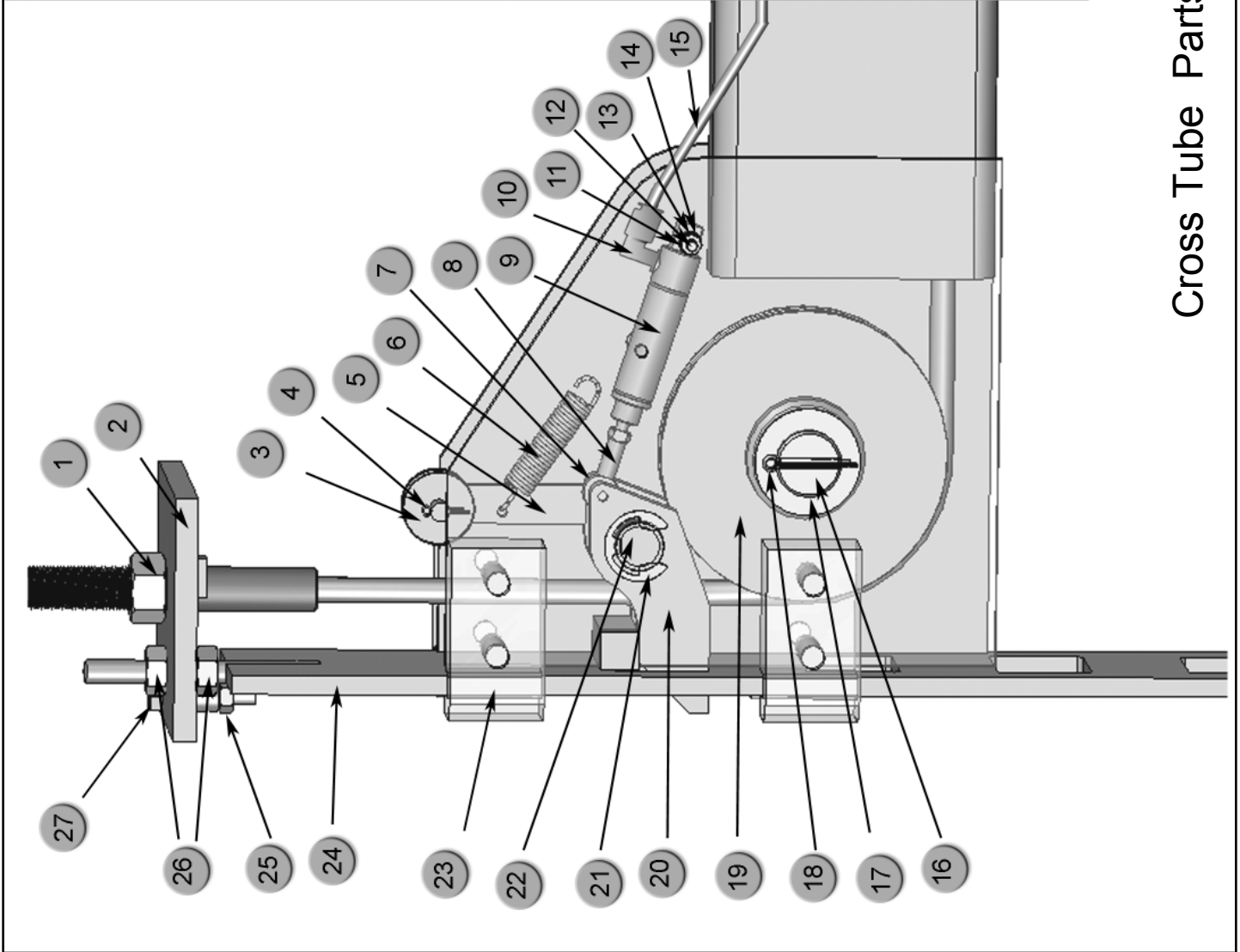

Cross Tube Parts List

Air Valve Parts List

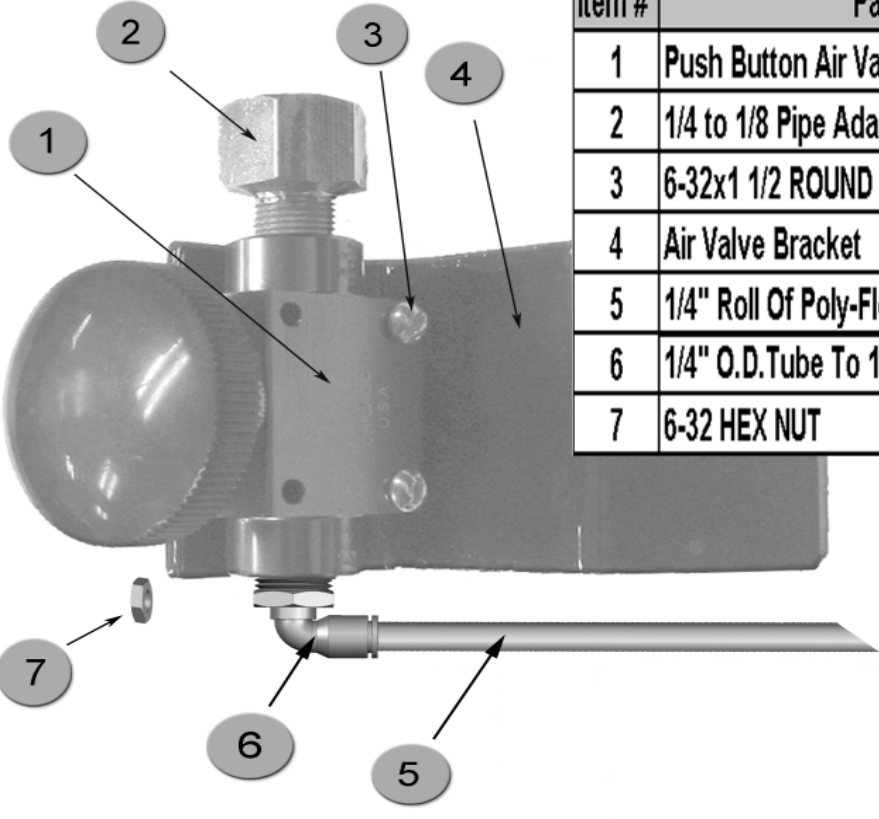

Item #	Part Description	Part No.	Qty
1	Push Button Air Valve	5590175	1
2	1/4 to 1/8 Pipe Adapter	5550486	1
3	6-32x1 1/2 ROUND SLOT HEAD	5530117	4
4	Air Valve Bracket	5701190	1
5	1/4" Roll Of Poly-Flo Tubing	5570795	1
6	1/4" O.D. Tube To 1/8 NPT 90° Push To Connect	5550481	1
7	6-32 HEX NUT	5535190	4

MAINTENANCE RECORDS

INSTALLATION FORM

Customer Name:		Date of Installation:	
Company Name:			
Street Address:			
City:	State:	Zip:	
Phone:		Fax:	

Pre-Install Agreement

I, (the undersigned) acting as the owner of the business listed above assume responsibility for any permits required, either state or county mandated, related to the installation and/or operation of this equipment. I assume responsibility for the concrete floor and condition thereof, now or later, where the above equipment model(s) are installed. I will assume all liability for losses, damages (including loss of use), expenses, demands, claims, and judgments in connection with or arising out of any personal injury or alleged damage to property, sustained or alleged to have been sustained in connection with, or to have arisen out of the condition and/or drilling of the concrete near or adjacent to the equipment model(s) listed above. If my employee(s) offer assistance of any kind during installation of the above equipment model(s) I hold the manufacturer and installation company harmless of all liability for losses, damages, expenses, claims, and judgments in connection with or arising out of any personal injury or alleged damage to property, sustained or alleged to have been sustained in connection with the installation of the above equipment model(s).

I understand that the lifts above are supplied with concrete fasteners meeting the criteria of the American National Standard "Automotive Lifts - Safety Requirements for Construction, Testing, and Validation" ANSI/ALI ALCTV-1998, and that I will be responsible for all charges related to any special regional structural and/or seismic anchoring requirements specified by any other agencies and/or codes such as the Uniform Building Code (UBC) and/or International Building Code (IBC).

Customer Signature: _____ Print Name: _____ Date: _____

Post-Installation Check-Off

- | | |
|--|--|
| <input type="checkbox"/> Base and Columns Properly Shimmed And Stable
<input type="checkbox"/> Anchor Bolts Tightened
<input type="checkbox"/> Runways Properly Attached and Secured
<input type="checkbox"/> Electric Power Supply Confirmed
<input type="checkbox"/> Cables / Chains Adjusted Properly
<input type="checkbox"/> Safety Locks Functioning Properly
<input type="checkbox"/> Check For Hydraulic Leaks
<input type="checkbox"/> Oil Level | <input type="checkbox"/> Lubrication of Critical Components
<input type="checkbox"/> Lift Adapters
<input type="checkbox"/> Check For Overhead Obstructions
<input type="checkbox"/> Runways Level
<input type="checkbox"/> All Screws, Bolts, and Pins Secured
<input type="checkbox"/> Surrounding Area and Lift Clean In Appearance
<input type="checkbox"/> Proper Operation, Maintenance and Safety Explained
<input type="checkbox"/> Operation and Safety Manual(s) Left at Site |
|--|--|

I, (the undersigned) confirm that the above installation procedure(s) were completed. I understand that I will be responsible for maintaining this equipment as outlined in the accompanied **Installation and Operation Manual** and **ANSI/ALI ALOIM Safety Requirements for Operation, Inspection and Maintenance**. I understand that personal injury and/or damage to property can occur if the above equipment model(s) are not maintained or used improperly and take full responsibility for training my employees on proper use and maintenance of this equipment. I hold the manufacturer and installation company harmless of all liability for losses, damages (including loss of use), expenses, demands, claims, and judgments in connection with or related to improper use, improper training, or lack of required maintenance. I understand that the warranty does not cover replacement of parts worn or damaged due to normal use or lack of required maintenance

Customer Signature: _____ Print Name: _____ Date: _____

Installer Signature: _____ Print Name: _____ Date: _____

Installer Company Name: _____

Street Address: _____

City:	State:	Zip:
Phone:	Phone (Other):	

OPTIONAL EQUIPMENT



Brand: BendPak
 Model: RJ-45 / RJ-6 / RJ-9
 Description: Rolling Bridge Jacks

These optional rolling bridge jacks offer the ultimate in jacking speed and convenience. Their exclusive telescoping roller design allows the runways to be adjusted for different tread widths. Precision rollers enable you to position them anywhere under the vehicle. Perfect for wheel and suspension work. Each jack comes complete with stackable pad adapters.

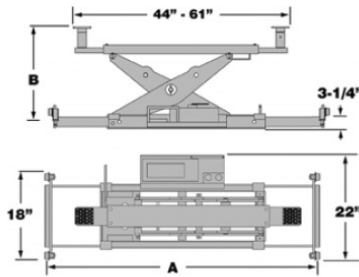

RJ-45 / RJ-6

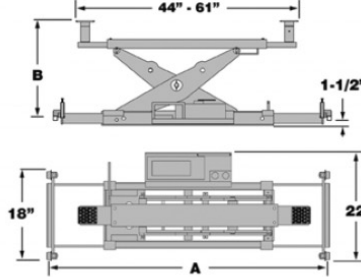

RJ-9

MODEL	RJ-45	RJ-6	RJ-9
Lifting Capacity:	4,500 lbs. / 2041 Kg.	6,000 lbs. / 2722 Kg.	9,000 lbs. / 4082 Kg.
A - Min. Width	35" / 889 mm.	35" / 889 mm.	41" / 1041 mm.
A - Max. Width	45-1/2" / 1156 mm.	45-1/2" / 1156 mm.	51-1/2" / 1308 mm.
B - Min. Pad & Adapter:	8" / 203 mm.	10" / 254 mm.	13-1/4" / 337 mm.
B - Min. Pad Only:	4-1/2" / 114 mm.	6-1/2" / 102 mm.	9-3/4" / 248 mm.
B - Max. Pad & Adapter:	18" / 457 mm.	20" / 508 mm.	23-1/4" / 591 mm.
B - Max. Pad Only:	14-1/2" / 368 mm.	16-1/2" / 419 mm.	19-3/4" / 502 mm.
Min. Arm Reach:	40-1/4" / 1022 mm.	40-1/4" / 1022 mm.	40-1/4" / 1022 mm.
Max. Arm Reach:	63-1/4" / 1607 mm.	63-1/4" / 1607 mm.	63-1/4" / 1607 mm.

The design, material and specifications are subject to change without notice.

BendPak, BendPak Incorporated and Ranger Products and their respective logos are registered trademarks. Copyright 2005 BendPak Incorporated

BendPak / Ranger, 1645 Lemonwood Dr., Santa Paula, CA 93060
 Tel: 1-805-933-9970 Fax: 1-805-933-9160



The best automotive service equipment on the planet.

**For Parts Or Service
Contact:**

**BendPak Inc. / Ranger Products
1645 Lemonwood Dr.
Santa Paula, CA. 93060**

**Tel: 1-805-933-9970
Toll Free: 1-800-253-2363
Fax: 1-805-933-9160**

**www.bendpak.com
www.rangerproducts.com**

