



1645 Lemonwood Dr.
Santa Paula, CA, 93060 USA
Toll Free (888) 977-8225
Tel: (805) 933-9970
autostacker.com

Autostacker™ Parking Lift

Installation and Operation Manual

Manual P/N 5900248 — Manual Revision B1 — May 2022

Models:

- A6S
- A6W



U.S. Design Patent No. D814,736

Autostacker is designed and engineered by BendPak Inc. in Southern California, USA. Made in China.

 **DANGER**

Read the *entire contents* of this Manual *before* using this product. Failure to follow the instructions and safety precautions in this manual can result in serious injury or death. Make sure all other operators also read this manual. Keep the manual near the product for future reference.
By proceeding with setup and operation, you agree that you fully understand the contents of this manual and assume full responsibility of product use.

Manual. Autostacker Parking Lift, *Installation and Operation Manual*, Manual P/N 5900248, Manual Revision B, Released May 2022.

Copyright. Copyright © 2022 by BendPak Inc. All rights reserved. You may make copies of this document if you agree that: you will give full attribution to BendPak Inc., you will not make changes to the content, you do not gain any rights to this content, and you will not use the copies for commercial purposes.

Trademarks. BendPak and the BendPak logo are registered trademarks of BendPak Inc. Autostacker is a trademark of BendPak Inc. All other company, product, and service names are used for identification only. All trademarks and registered trademarks mentioned in this manual are the property of their respective owners.

Limitations. Every effort has been made to ensure complete and accurate instructions are included in this manual. However, product updates, revisions, and/or changes may have occurred since this manual was published. BendPak reserves the right to change any information in this manual without incurring any obligation for equipment previously or subsequently sold. BendPak is not responsible for typographical errors in this manual. You can always find the latest version of the manual for your product on the **Autostacker** website.

Warranty. The Autostacker warranty is more than a commitment to you: it is also a commitment to the value of your new product. For full warranty details, contact your nearest Autostacker dealer or visit [autostacker.com/support/warranty](https://www.autostacker.com/support/warranty).

Safety. Your product was designed and manufactured with safety in mind. Your safety also depends on proper training and thoughtful operation. Do not set up, operate, maintain, or repair the unit without reading and understanding this manual and the labels on the unit; **do not use this product unless you can do so safely!**

Owner Responsibility. In order to ensure operator safety and maintain your product properly, it is the responsibility of the product owner to read and follow these instructions:

- Follow all setup, operation, and maintenance instructions.
- Make sure product setup conforms to all applicable local, state, and federal codes, rules, and regulations, such as state and federal OSHA regulations and electrical codes.
- Read and follow all safety instructions. Keep them readily available for operators.
- Make sure all operators are properly trained, know how to safely operate the unit, and are properly supervised.
- Do not operate the product until you are certain that all parts are in place and operating correctly.
- Carefully inspect the product on a regular basis and perform all maintenance as required.
- Service and maintain the unit only with approved replacement parts.
- Keep all instructions permanently with the product and make sure all labels are clean and visible.
- **Autostacker, BendPak** makes no promises, guarantees or assurances that our products meet any state, county, federal or international mandated permit, license, code, standard, certification, or any other mandate other than what is listed or shown on BendPak website(s), or any BendPak or Ranger online or published catalog. Not all BendPak lift models meet the standards as prescribed by ANSI/ALI ALCTV-(current edition) or ANSI/UL 201. Consult www.autolift.org for a complete list of lift models that meet ANSI/ALI ALCTV-(current edition) or ANSI/UL 201, or contact BendPak via contact@bendpak.com. **Buyer assumes full responsibility for any state, county, federal or international mandated permit, license, code, standard, certification, or any other mandate required related to the installation and/or operation of any BendPak or Autostacker product.** BENDPAK will not be responsible for any charges, fines, liens, or other levies imposed on the Buyer related to any special or regional structural, seismic or any other building code and/or codes such as the Uniform Building Code (UBC), International Building Code (IBC), or any other state, county, federal or international mandated permit, license, code, standard, certification, or other mandate, law, rule, regulation or directive by any other agency, government, administrations, or corporations whether state, county, federal, or international mandated.
- **Only use this product if it can be used safely!**

Unit Information. Enter the Model Number, Serial Number, and the Date of Manufacture from the label on your unit. This information is required for part or warranty issues.

Model: _____

Serial: _____

Date of Manufacture: _____

BP BendPak Santa Paula, CA USA www.bendpak.com	
MODEL NUMBER	
DESCRIPTION	
LIFT CAPACITY	DATE OF MFG.
VOLTAGE	
<input type="checkbox"/> 110-240V, 50-60 Hz, 1 Ph	
<input type="checkbox"/> 208-240V, 50-60 Hz, 1 Ph	
<input type="checkbox"/> 380-415V, 50-60 Hz, 3 Ph	
<input type="checkbox"/> 208-440V, 50-60 Hz, 3 Ph	
SERIAL NUMBER	
UPC	
DANGER! Disconnect Power Before Servicing	
WARRANTY VOID IF DATA PLATE IS REMOVED PN 5905950	
CE EAC	

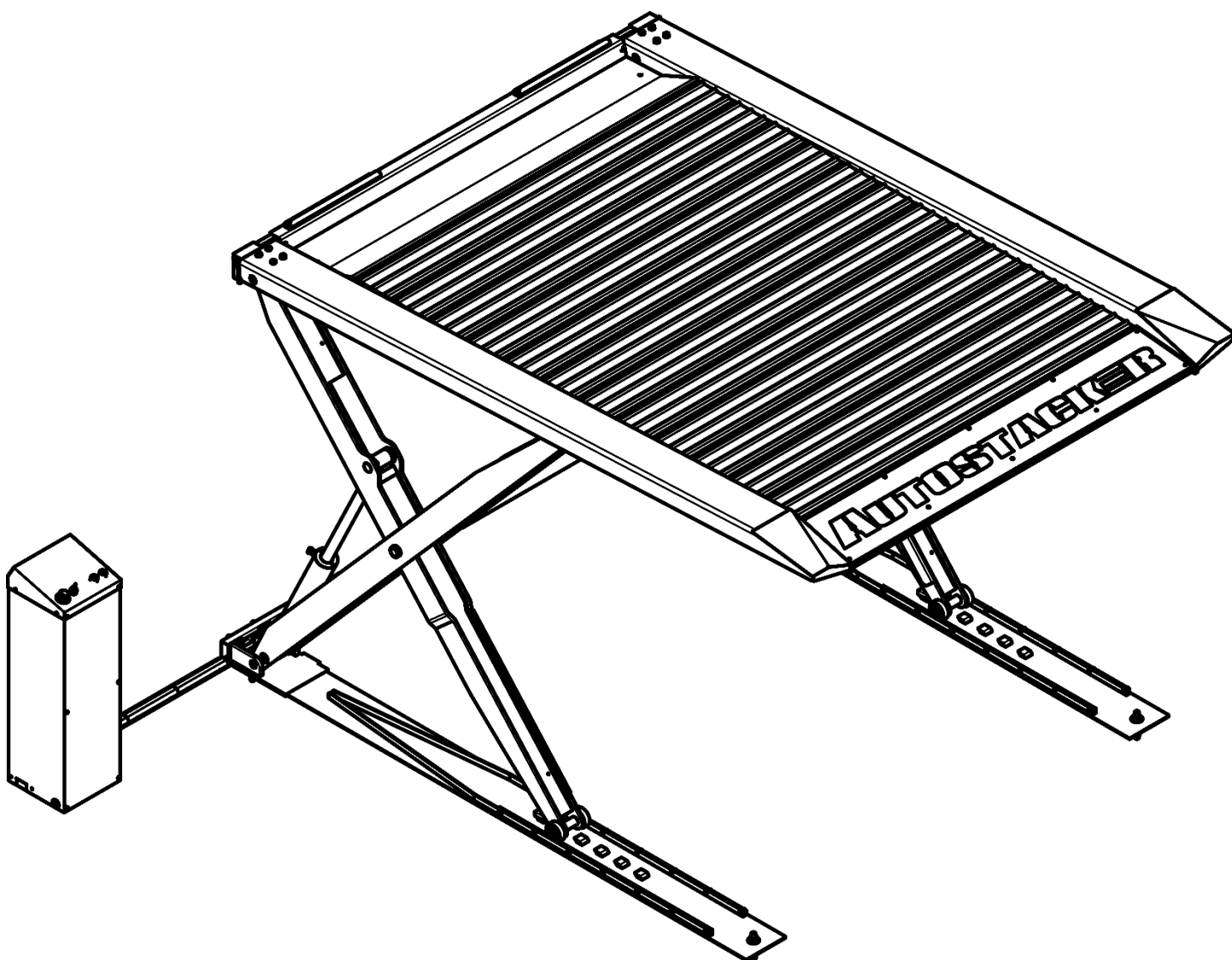

Table of Contents

Introduction	4	Installation	13
Shipping Information	5	Operation	39
Safety Considerations	5	Maintenance	49
FAQ	7	Troubleshooting	50
Specifications	8	Multi-Autostacker	53
Components	8	Wiring Diagrams	69
Will My Cars Fit?	9	Labels	72
Orientation	11	Parts Diagrams	78
Installation Checklist	12	CE Certificate	87

Introduction

Autostacker is available in two versions:

- **A6S**. Parking Lift that allows you to make a parking spot that holds just one Vehicle into a parking spot that holds two Vehicles, lifting vehicles up to 6,000 lbs (2,722 kg).
- **A6W**. Wide version of the A6S, with an extra 8 inches of width for your Vehicles.

Autostacker is also available in a **Multi-Lift** configuration, where you can control up to 12 Lifts using a single Master Power Unit.

Unless specifically stated, the setup for each Autostacker in a Multi-Lift configuration follows the same installation process as a single Autostacker. See **Multi-Autostacker** towards the end of this manual for those modified procedures. After you have completed those modified procedures, continue the remainder of the installation as you would with a single Autostacker; see the **Installation Checklist** for an overview of the installation process.

This Manual is mandatory reading for **all Autostacker Lift installers and users**.

⚠ DANGER Be very careful when setting up, operating, maintaining, or repairing this equipment; failure to do so could result in property damage, product damage, injury, or (in very rare cases) death. Make sure only authorized personnel operate this equipment. All repairs must be performed by an authorized technician. Do not make modifications to the unit; this voids the warranty and increases the chances of injury or property damage. Make sure to read and follow the instructions on the labels on the unit.

Keep this manual on or near the equipment so that anyone who uses or services it can read it.

Technical support for your product is available directly from your distributor or you can contact autostacker.com/support or support@autostacker.com. You can also ask for replacement parts (please have the serial number and model number of your unit available).

Shipping Information

Your equipment was carefully checked before shipping. Nevertheless, you should always thoroughly inspect the shipment before you sign to acknowledge that you received it.

When you sign the bill of lading, it tells the carrier that the items on the invoice were received in good condition. ***Do not sign the bill of lading until after you have inspected the shipment.*** If any of the items listed on the bill of lading are missing or damaged, do not accept the shipment until the carrier makes a notation on the bill of lading that lists the missing and/or damaged goods.

If you discover missing or damaged goods ***after*** you receive the shipment and have signed the bill of lading, notify the carrier at once and request the carrier to make an inspection. If the carrier will not make an inspection, prepare a signed statement to the effect that you have notified the carrier (on a specific date) and that the carrier has failed to comply with your request.

It is difficult to collect for loss or damage after you have given the carrier a signed bill of lading. If this happens to you, file a claim with the carrier promptly. Support your claim with copies of the bill of lading, freight bill, invoice, and photographs, if available. Our willingness to assist in helping you process your claim does not make us responsible for collection of claims or replacement of lost or damaged materials.

Safety Considerations

Read this manual carefully before using your new product. Do not set up or operate the product until you are familiar with all operating instructions and warnings. Do not allow anyone else to operate the product until they are also familiar with all operating instructions and warnings.

General Safety Information

Please note the following:

- The product is a **Parking Lift**. Use it only for its intended purpose. Do not make any modifications.
- The product must only be operated by authorized personnel.
- Always wear the appropriate protective clothing when installing, servicing, or repairing your Lift.
- Keep loads centered and balanced on the Platform. Do not overload the Rear end; Autostacker is designed to support an equal load.
- Use caution when driving onto the Platform with a Vehicle with wet tires.
- When the product is in use, keep all body parts away from it.
- Do not leave the Lift without confirming that each Leg Base is secured on a Safety Lock.
- Make sure all operators read and understand the *Installation and Operation Manual*. Keep the manual near the device at all times.
- Make a visual inspection of the product before using it. Check for damaged or missing parts. Do not use the product if you find any issues. Instead, take it out of service, then contact your distributor, or Autostacker at autostacker.com/support or support@autostacker.com.
- Make a thorough inspection of the product at least once a year. Replace any damaged or severely worn parts, decals, or warning labels.
- Routine maintenance and adjustments are the responsibility of the owner and should be carried out on a regular basis. For more complex maintenance and repairs, contact your independent maintenance contractor.

Symbols

Following are the symbols used in this manual:



DANGER Calls attention to an immediate hazard that **will** result in injury or death.



WARNING Calls attention to a hazard or unsafe practice that **could** result in injury or death.



CAUTION Calls attention to a hazard or unsafe practice that could result in minor personal injury, product, or property damage.

NOTICE

Calls attention to a situation that, if not avoided, could result in product or property damage.



Tip

Calls attention to information that can help you use your product better.

Liability Information

BendPak Inc. assumes **no** liability for damages resulting from:

- Use of the product for purposes other than those described in this manual.
- Modifications to the equipment without prior, written permission from BendPak Inc.
- Injury or death caused by modifying, disabling, overriding, or removing safety features.
- Damage to the equipment from external influences.
- Incorrect operation of the equipment.

Frequently Asked Questions

Question: What kinds of Vehicles is Autostacker designed for?

Answer: Autostacker is designed for cars, light trucks, and SUVs.

Q: Why is the Platform angled?

A: The angled Platform allows low-profile Vehicles to drive directly onto the Platform without scraping.

Q: How high does my garage ceiling have to be to use Autostacker?

A: Autostacker works great with ceilings as low as 10 feet. However, the height of the ceiling does impact what cars you can park on the Lift. Refer to [Will My Car Fit?](#) for complete information.

Q: Can I put the Console on either side of the Autostacker?

A: Yes. The included Hydraulic Hoses are long enough to support the Console being up to 30 inches away on either side. If you want, you could go to your local hydraulics shop and get longer, custom-made Hydraulic Hoses that give you greater latitude for where you put your Console.

Q: Does it matter if I drive my Vehicles in straight or back them in?

A: No, Autostacker works great either way. For the Vehicle **on** the Platform, make sure the wheels are in the Tire Trough, whichever direction you drive it on. For the Vehicle **under** the Platform, put it in whichever direction makes it easier to open the doors. Note that it is not required that you drive your Vehicle all the way underneath the Platform; for some Vehicles, opening the doors is easier if you only drive part way in.

Q: How long can I leave a Vehicle raised on the Autostacker?

A: As long as you want, **if it is engaged on a Safety Lock**. Autostacker is great for storage in any condition, long or short-term.

Q: How many Safety Locks does my Lift have?

A: 5. See [Raising a Vehicle](#) for the different locking heights.

Q: Can I change the oil on the Vehicle raised on the Autostacker?

A: Yes; the optional Access Panel gives you access to the underside of the Vehicle that is raised, making your parking lift into a service lift as well. Each Access Panel works in place of three Platform sections and you can install **up to two** Access Panels per Autostacker.

Q: How many Lifts can be supported by the Master Power Unit?

A: The Master Power Unit can support up to 12 Autostacker Lifts, although **only one Lift can be raised and lowered at a time**.

Specifications

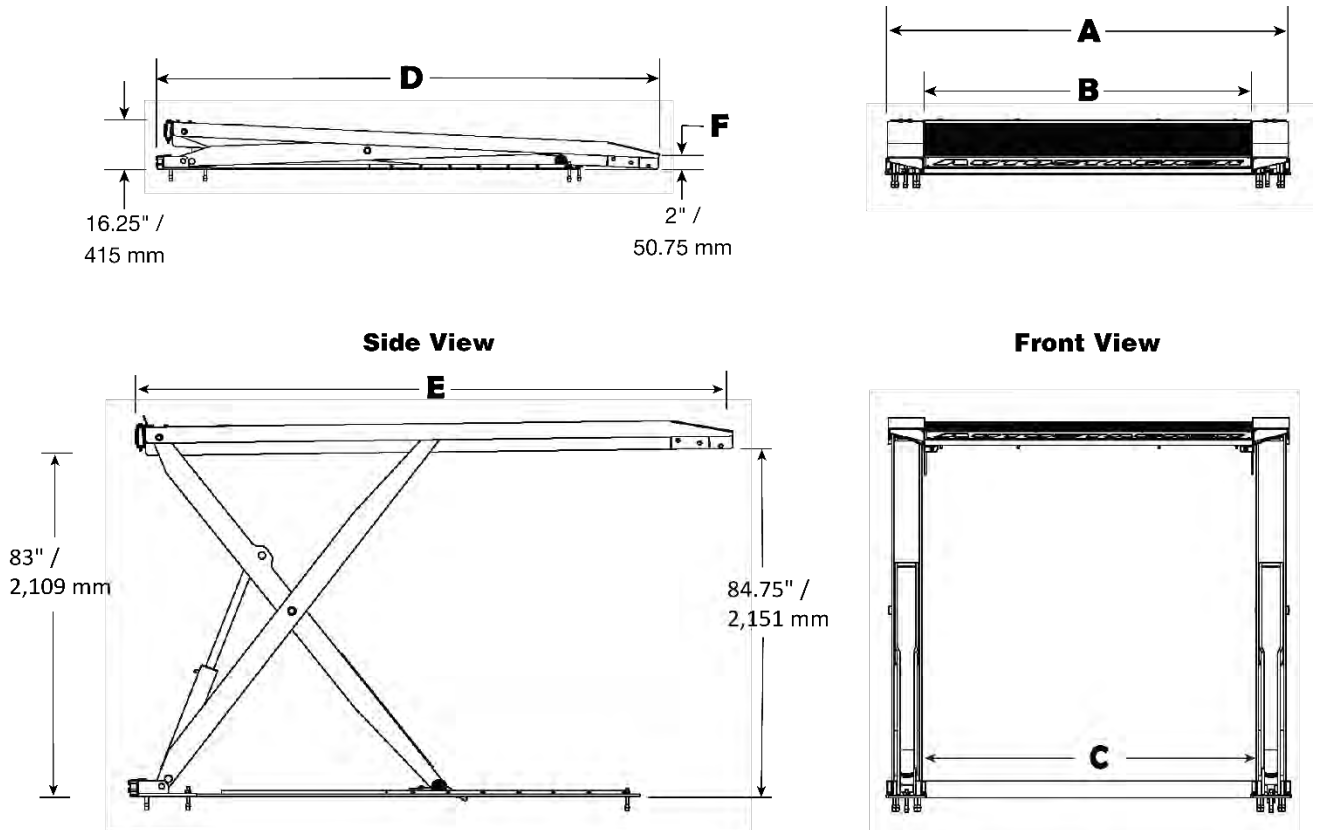

Specifications	A6S	A6W
Lifting capacity	6,000 lbs. / 2,722 kg	
A Total width	103 in. (8.6 feet) / 2,620 mm	111 in. (9.3 feet) / 2,815 mm
B Platform width	83.75 in. (7 feet) / 2,127 mm	91.75 in. (7.7 feet) / 2,331 mm
C Drive-thru width	83 in. (7 feet) / 2,112 mm	90.75 in. (7.7 feet) / 2,305 mm
D Overall length	144 in. (12 feet) / 3,652 mm	
E Platform plus ramp	141 in. (11.9 feet) / 3,580 mm	
F Ramp height	2 in. / 51 mm	
Platform only	124 in. (10.4 feet) / 3,150 mm	
Maximum wheelbase	132 in. (11 feet) / 3,352 mm	
Maximum under clearance	80 in. (6.7 feet) / 2,032 mm	
Rise/Lower Speed	55 seconds / 35 seconds	
Motor	<ul style="list-style-type: none"> • 220 VAC at 50 Hz, 208-230 VAC at 60 Hz, 1 Ph • 380 VAC at 50 Hz, 3 Ph • 110 VAC at 50/60Hz, 1 Ph 	

If you have a **Multi-Lift** setup, see **Multi-Autostacker** for modified specifications.

Components

Autostacker components include:

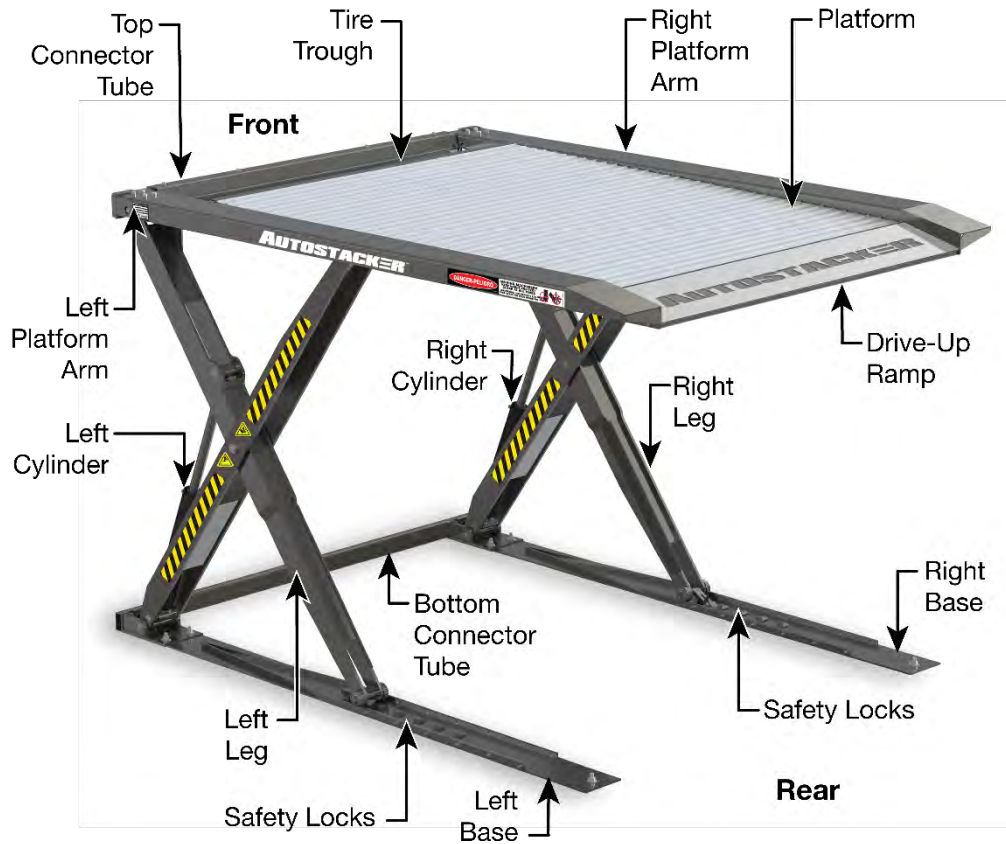

The following drawing shows the two possible locations for the Lift Controls:

- **Console.** Positioned at the Front of the Lift, on either side. For a Single-Lift configuration.
- **Control Stand.** Can be positioned at the Front or Rear of the Lift. Separate installation for either orientation. For a Multi-Lift configuration.

Console (Single-Lift):



Control Stand (Multi-Lift):



Will My Cars Fit?

Autostacker accommodates a wide variety of cars, light trucks, and SUVs. This section describes how to get wider, longer, and taller Vehicles onto your Autostacker.

Width

Considerations for Vehicle width include:

- **Platform width.** The width from the outside of the left tires to the outside of the right tires cannot exceed the width of the Platform. The tires **must** fit on the Autostacker Platform.
- **Mirrors.** Mirrors and other accessories may mean that some parts of a Vehicle are much wider than the tires of the Vehicle. This is generally not a problem on a raised Vehicle, but should be taken into consideration for Vehicles being parked under the Autostacker.
- **Doors.** Opening car doors makes the Vehicle wider while they are open. If opening Vehicle doors is an issue, try driving in the Vehicle in the other direction. Autostacker Legs have Door-sentry car door protectors, which limit problems if a door does contact an Autostacker Leg.

Length

Considerations for Vehicle length include:

- **Vehicle wheelbase.** Vehicles that get raised on the Platform must have one set of wheels in the Tire Trough and the other set on the Platform itself.
- **Overhang.** If a Vehicle's wheelbase fits on the Platform, then any overhanging parts of the Vehicle outside the wheelbase are not an issue.

Height

Considerations for Vehicle height include:

- **Ceiling height.** The height of the ceiling determines how much space you have for the two Vehicles. If you want to park both a tall Vehicle on and under your Autostacker, your ceiling needs to be higher than if you want to park two low-slung Vehicles.
- **Formula.** There's a formula for figuring out how high a ceiling you need.

Height of Vehicle on Platform + 6 inches + Safety Lock height

For example: Say you have a 2017 Camaro and a 2017 Toyota Camry. The Camry is 58 inches high, the Camaro is 53 inches. If you want the Camry under the Platform and the Camaro on it, the formula would be $53 + 6 + 68.5$ (third Safety Lock) = 127.5 inches. If you have a 12 foot high ceiling, you have 144 inches to use, so this combination would fit fine.

The 6 inch figure includes the height of the Platform plus the height needed to raise the Lift off of the Safety Lock. Note this figure is a rough estimate, for calculation purposes only.

 **CAUTION** We recommend double checking your ceiling and Vehicle heights before raising a Vehicle on the Autostacker Platform. ***Be especially vigilant the first time you raise a particular Vehicle!*** No one wants to see the roof of their Vehicle make contact with the ceiling. Use the Emergency Stop button if necessary.

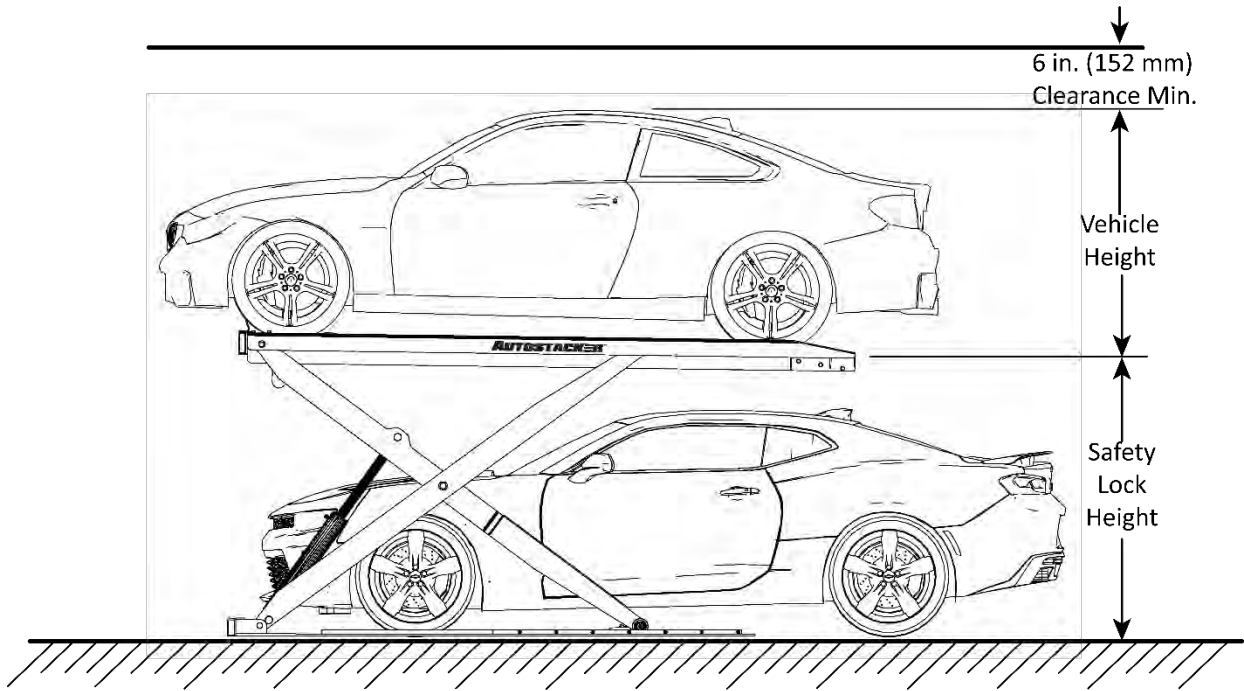

Orientation

The Console may be placed on either side of the Lift up to 30 inches away from the Lift.

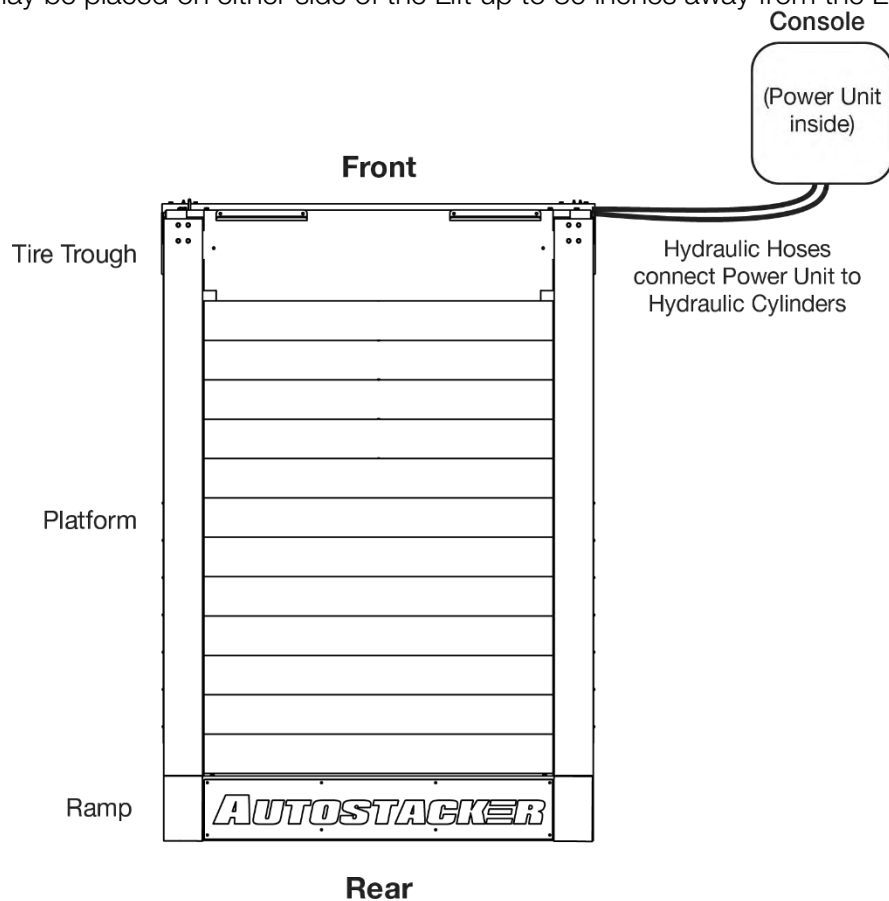

Not all components are shown. Drawing not necessarily to scale.

Installation Checklist

Following are the steps needed to install an Autostacker; perform them in this order.

- 1. Review the installation Safety Rules.
- 2. Make sure you have the necessary Tools.
- 3. Plan for Electrical Work.
- 4. Select the installation site.
- 5. Check Clearances around the Lift.
- 6. Create a floor plan.
- 7. Position the Leg Assemblies and other components.
- 8. Attach the Bottom and Top Connector Tubes.*
- 9. Anchor the Bases to the ground.
- 10. Set up the Console and attach the Power Unit.*
- 11. Connect the Hydraulic Hoses.*
- 12. Connect the Return Lines.*
- 13. Connect the Power Unit.*
- 14. Attach the Conduit Tube.*
- 15. Install the Control Stands.*
- 16. Wiring a Power Disconnect Switch.
- 17. Install a Thermal Disconnect Switch.
- 18. Test the Autostacker.
- 19. Add the Tire Trough and Tire Stops.
- 20. Add the Platform sections and Drive-Up Ramp.
- 21. Lubricate the Autostacker.
- 22. Review the Final Checklist.

Procedures modified and/or specific to a **Multi-Lift configuration only. See **Multi-Autostacker** for more information.*

Installation

This section describes how to install your Autostacker. Perform the steps in the order listed.

 **WARNING** *Only use the factory-supplied parts that came with your Lift.* If you use parts from a different source, you void your warranty and compromise the safety of everyone who installs or uses the Lift. If you are missing parts, visit autostacker.com/support or call **(888) 977-8225**.

Safety Rules

When installing your Autostacker, your safety depends on proper training and thoughtful operation.

 **WARNING** Do not install this equipment unless you have automotive lift installation training. Always use proper lifting tools, such as a Forklift or Shop Crane, to lift heavy components. Do not install this equipment without reading and understanding this manual and the safety labels on the unit.

Only fully trained personnel should be involved in installing this equipment. ***Pay attention at all times.*** Use appropriate tools and lifting equipment, when needed. Stay clear of moving parts.

BendPak recommends referring to the current version of the ANSI/ALI ALIS Standard *Safety Requirements for Installation and Service* for more information about safely installing, using, and servicing your Lift.

 **WARNING** You ***must*** wear OSHA-approved (publication 3151) personal protective equipment at all times when installing, using, maintaining, or repairing the Autostacker: leather gloves, steel-toed work boots, eye protection, back belts, and hearing protection are ***mandatory***.

Tools

You may need some or all of the following tools:

- Rotary hammer drill or similar
- 3/4", 3/8" masonry bits
- Hammer and crow bar
- Open-end wrench set
- Socket and ratchet set
- Medium crescent wrench
- Chalk line and tape measure
- Medium flat screwdriver
- Forklift or Shop Crane

Electrical Work

You will need to have a licensed, certified Electrician available at some point during the installation.

 **DANGER** All wiring *must* be performed by a licensed, certified Electrician.

The Electrician needs to do these things:

- **Connect the selected power source to the bottom of the Power Disconnect Switch.** *Required.* This is generally done when the Power Unit is being connected.
- **Connect the Power Unit to the top of the Power Disconnect Switch.** *Required.* This is generally done when the Power Unit is being connected.
- **Install a Thermal Disconnect Switch.** *Optional.* BendPak recommends connecting a Thermal Disconnect Switch or overload device (not supplied) to make sure the equipment shuts down in the event of an overload or an overheated motor.

Select a Site

Keep the following in mind when selecting a site for your Autostacker:

- **Enough space.** Make sure there is adequate space for the Autostacker on all four sides, plus enough height for the Vehicles you will be lifting. If architectural plans are available, use them to make sure there is adequate space for your planned layout.
- **No overhead obstructions.** Make sure the site is free of overhead obstructions such as heaters, building supports, electrical lines, lights, and so on.
- **Concrete specifications.** Do not install the lift on cracked or defective Concrete; additionally, a Anchor Bolts must be at least 6 inches from expansion joints in the concrete or from a wall. Make sure the concrete is at least 4.25 inches thick, 3,000 psi, and cured for at least 28 days if recently poured. Make sure the floor is defect-free, dry, and level.

 **WARNING** Do not install your Autostacker on a surface with 3° or more of slope. A 3° degree slope or greater could lead to property damage, personal injury, or death.

- **Power.** You will need a power source available near the Console.
- **Operating temperature.** Lift is designed to be used between temperatures of 0°F to 104°F (-20°C to 40°C).
- **Indoor installation.** Autostacker is designed for *indoor installations*.
- **Outdoor installation.** Autostacker is *not* designed for outdoor use. It has an operating ambient temperature range of 0°F to 104°F (-20°C to 40°C).
- **Second floor installs.** Do not install the Autostacker on a second floor or elevated floor without first consulting the building architect and getting their approval.
- **Dress properly.** Wear protective gear (like safety goggles, helmet, heavy gloves, suitable working clothes, safety boots, ear protection, and so on) when installing Autostacker. Do not wear loose clothing or jewelry; contain long hair; keep hair and clothing away from moving parts.

 **WARNING** *Always* wear appropriate protective gear when working on the Autostacker.

Important: Your Autostacker Lift is supplied with installation instructions and concrete fasteners that meet the criteria set by the current American National Standard “Automotive Lifts – Safety Requirements for Construction, Testing, and Validation” ANSI/ALI ALCTV. Lift buyers are responsible for any special regional, structural, or seismic anchoring requirements specified by any other agencies or codes, such as the Uniform Building Code or International Building Code.

Create a Floor Plan

You need to plan out, in advance, where the Autostacker is going to go. You should consider:

- **Access.** The Autostacker is a Parking Lift, so be sure you can drive Vehicles onto it.
- **Side clearance.** Consider whether or not you want enough room on the sides for people to walk around the Autostacker.
- **Front clearance.** Vehicles parked on the Platform may extend over the front.
- **Rear clearance.** You are not required to park a Vehicle all the way underneath the Platform. Depending on the Vehicle, it may be easier to get in to and out of the Vehicle if you only go partway under the Platform, as shown below.

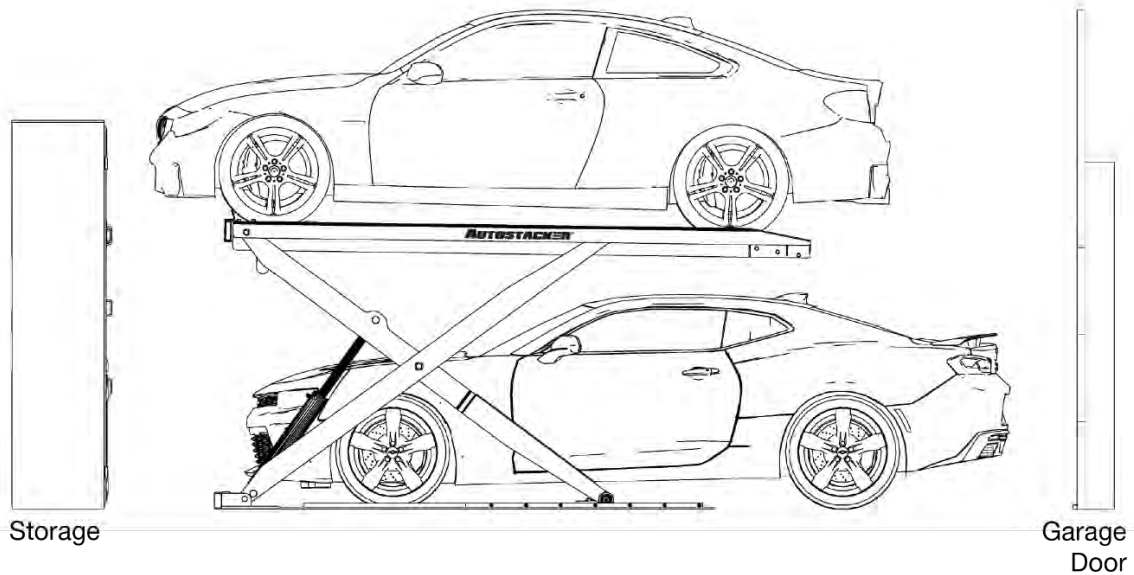

- **Console.** The Console must be located near the Autostacker; the Hydraulic Hoses that come with the Autostacker are optimized for up to 30 inches between the Autostacker and the Console.
- **Operator.** The operator at the Console must have a full, unobstructed view of the Autostacker.
- **Power.** The Console must also be positioned near the power source.

Create Chalk Lines Guides

Using Chalk Line Guides makes it easy to position the Autostacker components for installation.

Note: The front of the Autostacker is the end **opposite** the Drive-Up Ramp. The Tire Trough is at the front of the Autostacker and the Drive-Up Ramp is at the back.

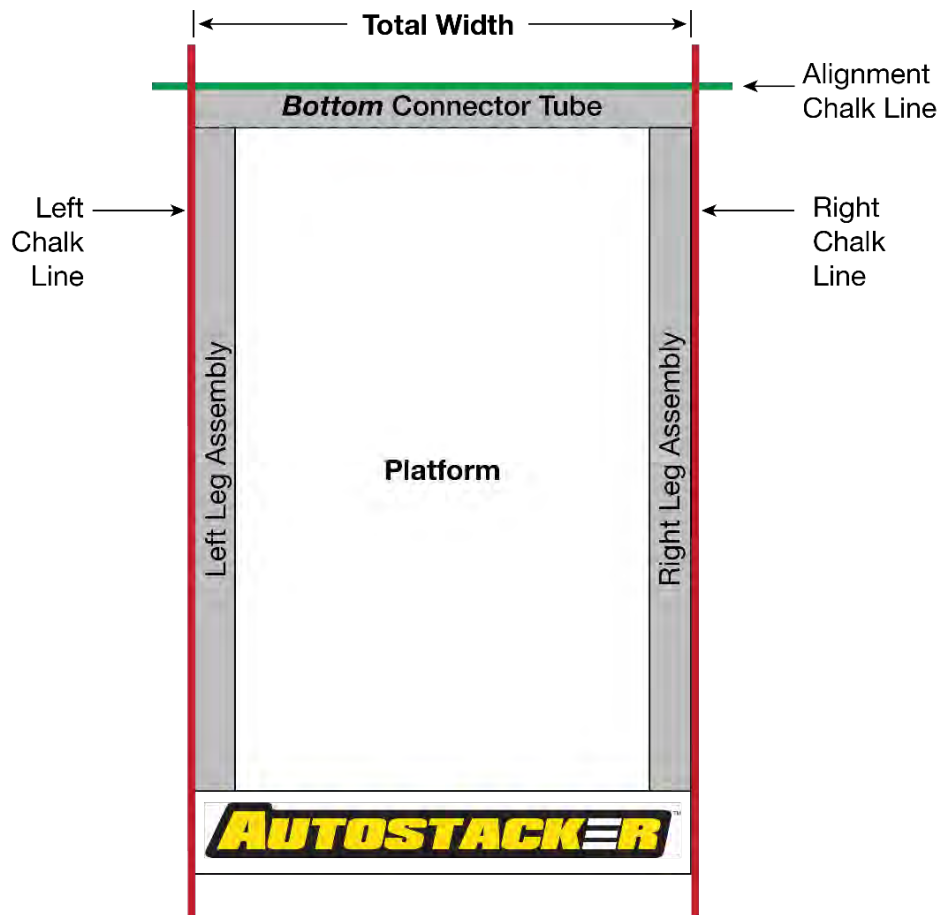

To add Chalk Line Guides:

1. Create an Alignment Chalk Line where you want the front of the Autostacker.
Make the Alignment Chalk Line **longer** than the Total Width setting for the Autostacker.
2. Create two perpendicular Chalk Lines at 90° angles to the Alignment Chalk Line.
Make the distance between the Left and Right Chalk Line the distance of the **Total Width** setting for the Autostacker, found in **Specifications**.
For a **Multi-Lift** setup, see **Multi-Autostacker** on Page 49 modified specifications. If you plan to position the Control Stand at the **Rear** of the Lift, use the Total Width (A); do **not** use the A1 figure.

Position the Autostacker Components

When the Lift components are delivered to the site, try to have them placed near where you will be installing the unit.

- ⚠ CAUTION** Some of the Autostacker components are heavy and can damage materials like tile, sandstone, and brick if not handled correctly. You must have a Forklift or Shop Crane to move them into position. Try to handle the Autostacker components only twice: once when delivered and once when moved into position.

Autostacker components include:

- **Two Leg Assemblies:** Each Leg Assembly includes a Base, Leg, Hydraulic Cylinder, and Platform Arm.
- **Bottom Connector Tube:** Connects to the Leg Assembly Bases. The Hydraulic Hoses and the Return Line are routed through the hollow Bottom Connector Tube.
- **Top Connector Tube:** Connects to the Leg Assembly Platform Arms. Also attaches to the Tire Trough.
- **Tire Trough:** A single piece with a lowered portion (to hold the Vehicle's tires from moving, which holds the Vehicle in place). Attaches to the Top Connector Tube and the first Platform section at the front of the Autostacker.
- **Platform:** Made up of galvanized steel sections that are bolted together.
- **Ramp:** A single piece, angled for easy drive-up.

To move the Leg Assemblies into position:

1. Use a Forklift or Shop Crane to move the Leg Assemblies into position based on the Chalk Lines. The Leg Assemblies go on the **inside** of the Chalk Lines.

- ⚠ CAUTION** Some of the Autostacker components are heavy and can damage materials like tile, sandstone, and brick if not handled correctly. Move the Leg Assemblies with care so that you do not cause damage to the surface.

2. Double check to make sure the Leg Assemblies are correctly positioned with the Door-Sentry car-door protectors on the inside; the Leg Assemblies are **not** interchangeable.

Attach the Bottom and Top Connector Tubes

The Bottom Connector Tube holds the bottom of the Autostacker structure together. It is hollow, allowing the Hydraulic Hoses and the Return Line to be routed through it.

The Top Connector Tube holds the top of the Autostacker structure together. Each end of the Top Connector Tube connects to the corresponding end of a Platform Arm.

If you have a **Multi-Autostacker** setup and plan to position the Control Stand at the **Rear** of the Lift, see **Multi-Autostacker** for modified instructions.

To attach the Bottom and Top Connector Tubes:

1. Move the Bottom Connector Tube into position: on the ground at the front of the Lift.

Important: The Bottom Connector Tube must be oriented so that the smaller gap must be at the top and the larger gap must be at the bottom. ***If you cannot push the Bolts through the Bottom Connector Tube and into the holes on the base of the Leg Assembly, it is probably because you have the Bottom Connector Tube oriented wrong.***

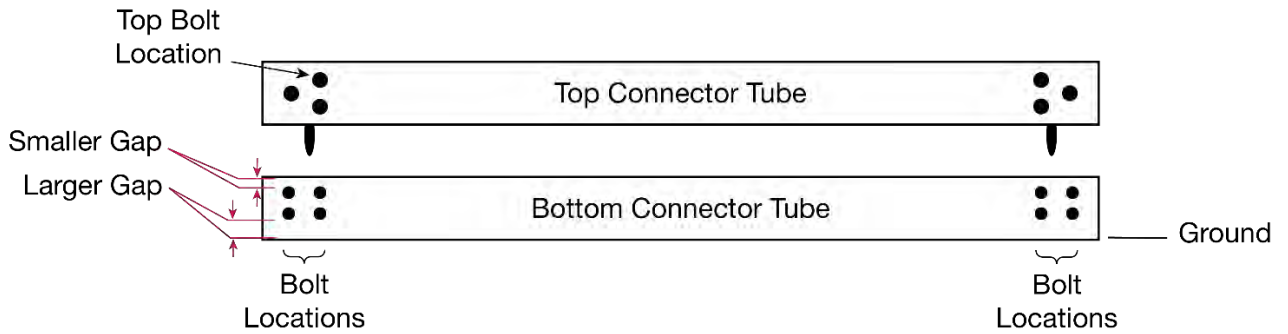

Not all components shown. View is front of Autostacker facing towards Rear.

2. Attach one end of the Bottom Connector Tube to a Leg Base using four Bolts from the Parts Box.
3. Use a Forklift or Shop Crane to lift the two Leg Assemblies onto the lowest Safety Lock (which is roughly 52 inches from the ground).
4. Take three Bolts from the Parts Box, then use them to connect one end of the Top Connector Tube to the corresponding end of a Platform arm.



Tip

The Top Connector Tube is heavy; you need at least two people to connect it (one person to hold the tube in place, one to connect the tube using the Bolts) or use a Forklift or Shop Crane to hold it in place while you connect it.

5. Take three more Bolts and use them to connect the other end of the Top Connector Tube to the corresponding end of a Platform Arm.

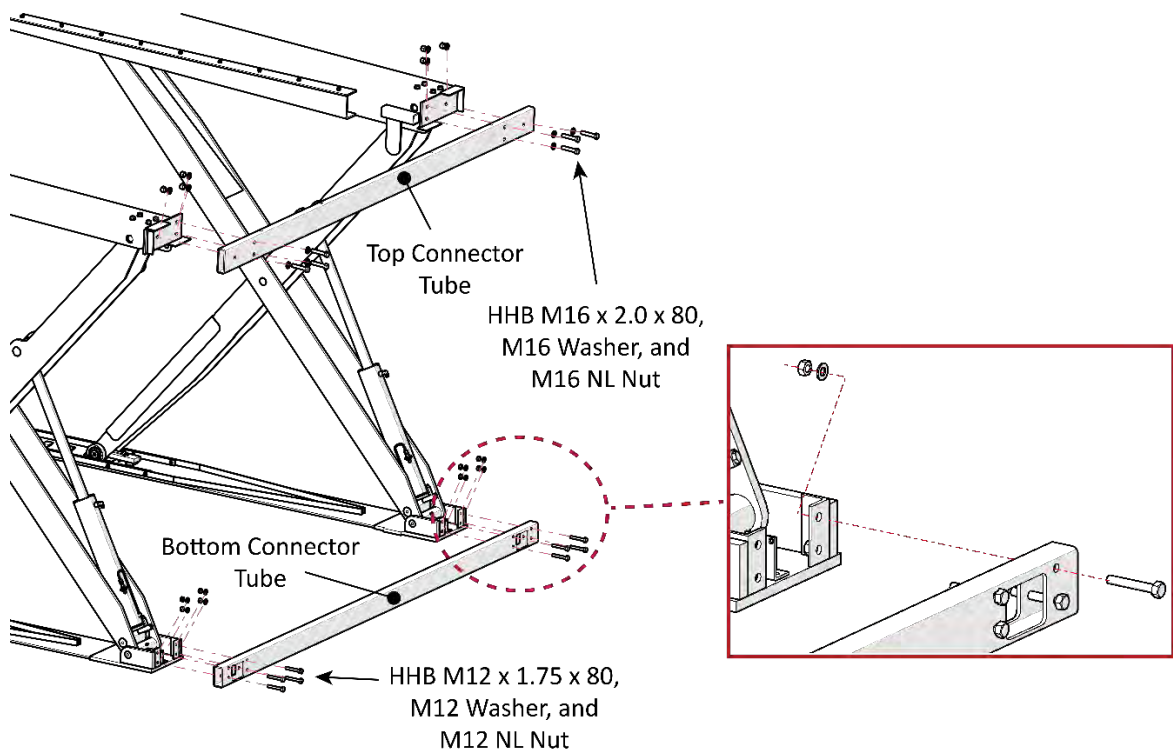

Drawing shows how to connect the Top and Bottom Connector Tubes to the Platform Arms. Not all components shown, some components exaggerated for clarity.

Anchor Bases to the Ground

Each Base has three holes in them for anchoring to the ground, with two holes placed in the front of each Leg Assembly and one located in the back.

Before you anchor your Autostacker, make sure the Leg Assemblies are correctly aligned. Measure to verify that the Left and Right Chalk Lines are parallel, then measure diagonally to make sure the two diagonal measurements are the same; this ensures your layout is correct.

⚠ CAUTION Poor alignment can affect how your Autostacker raises and lowers. Re-aligning the Leg Assemblies **after** you anchor them into place is difficult. It is well worth your time to align your Autostacker correctly before you anchor it into place.

⚠ WARNING You **must** wear OSHA-approved (publication 3151) personal protective equipment at all times when installing, using, maintaining, or repairing the Autostacker: leather gloves, steel-toed work boots, eye protection, back belts, and hearing protection are **mandatory**.

Concrete specifications are:

- **Depth:** 4.25 inches
- **PSI:** 3,000 psi, minimum
- **Cured:** 28 days, minimum

Anchor Bolt specifications are:

- **Length:** 4.75 inches
- **Diameter:** .75 inch
- **Anchor Torque:** 85 – 95 pound feet (do not torque more than 105 or less than 80)

The following drawing shows the locations of the Anchor Bolt holes in the Bases.

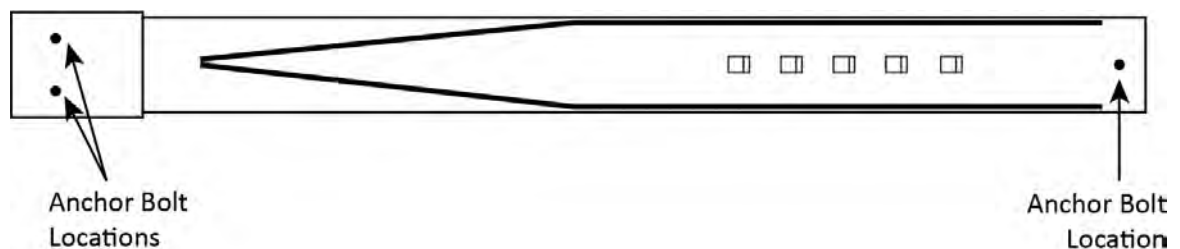

To anchor your Autostacker to the ground:

1. Verify the Bases are where you want them; once Anchor Bolts are torqued into position, they are **not** easily removed.
2. Using the holes in the Autostacker Bases as guides, drill the holes **4 inches / 101 mm** deep.

⚠ CAUTION Do **not** drill all the way through the Concrete; if you punch completely through the slab, you could compromise the holding strength of the Anchor Bolt.

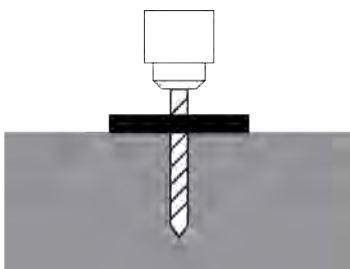

When drilling, go in straight; do not let the drill wobble.

Use a carbide bit (conforming to the current ANSI B212.15).

The diameter of the drill bit **must** be the same as the diameter of the Anchor Bolt. So if you are using a $\frac{3}{4}$ inch diameter Anchor Bolt, for example, use a $\frac{3}{4}$ inch diameter drill bit.

3. Use a wire brush or Vacuum to thoroughly clean each hole.

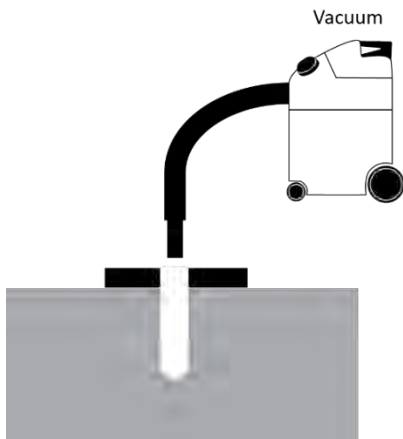

You can also use a hand pump or compressed air. Make sure to thoroughly clean the holes.

Do **not** ream the hole. Do **not** make the hole any wider than the drill bit made it.

4. Make sure the Washer and Nut are in place, then insert the Anchor Bolt into the hole.
5. Hammer or mallet the Wedge Anchor the rest of the way down into the hole.
Stop hammering when the Washer is snug against the Base.

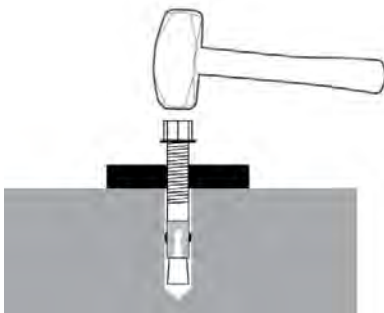

Use a hammer or mallet to get the Expansion Sleeve through the Base and down into the hole.

Even using a hammer or mallet, the Anchor Bolt should only go into the hole part of the way; *this is normal*. If the Anchor Bolt goes all the way in with little or no resistance, the hole is too wide.

Once past the hole in the Base, the Anchor Bolt eventually stops going down into the hole as the Expansion Sleeve contacts the sides of the hole; *this is normal*.

6. Wrench each Nut **clockwise** to the recommended installation torque, 85 – 95 pound feet, using a Torque Wrench.

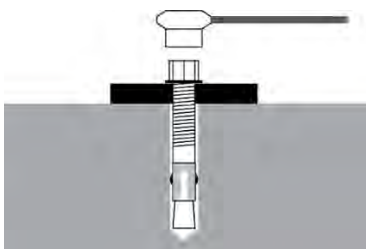

Wrenching the Nut forces the wedge up, pushing out the Expansion Sleeve and pressing it tightly against the Concrete.

Important: Do **not** use an impact wrench to torque the Anchor Bolts.

Assemble the Console and Attach the Power Unit

The Console can go on either side of the front of the Lift.



Tip

If you want to place the Console further than 30 inches from your Autostacker, you will need to get Hydraulic Hoses that are long enough to reach the Lift from where you want to put the Console. These should be relatively easy to obtain from the local hydraulics shop; you will also need a longer Return Line.

The following drawing shows the components that make up the Console.

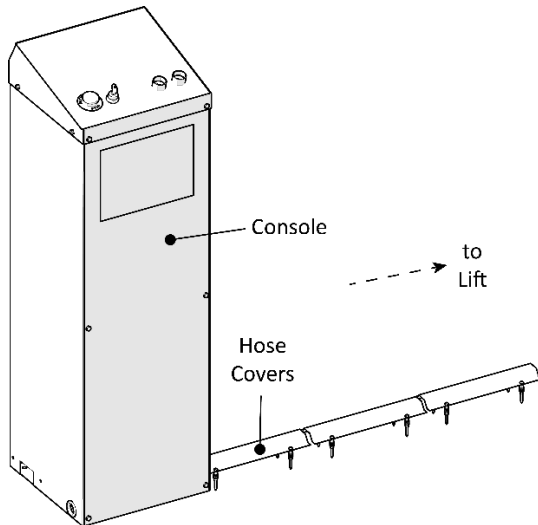

To assemble the Console and attach the Power Unit:

1. Select a site for the Console that permits operators to have a full, unobstructed view of the Lift.
2. Arrange all of the Console components as shown below.

Do not attach the Nuts at the top of the sides or the Back at this point; these will be attached later when you are ready to attach to the Top of the Console.

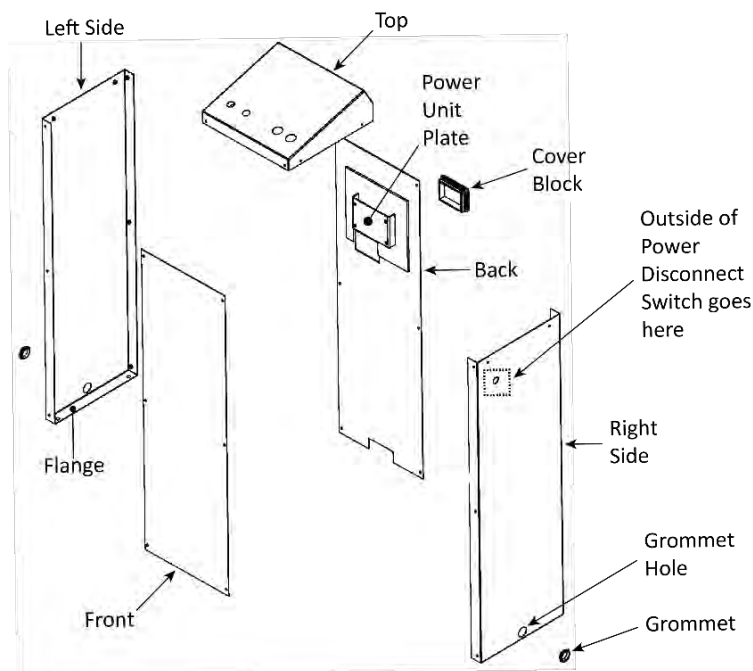

3. Remove the Power Unit from its packing material.
4. Stand up the Console, then attach the Power Unit to the Power Unit Plate using the supplied hardware.
5. Attach the Power Disconnect Switch; one piece goes on the inside of the Right Side, the clear piece goes on the outside of the Right Side; use four screws to connect the clear piece on the outside to the inside piece, then add the red/yellow switch on the outside using a single screw.

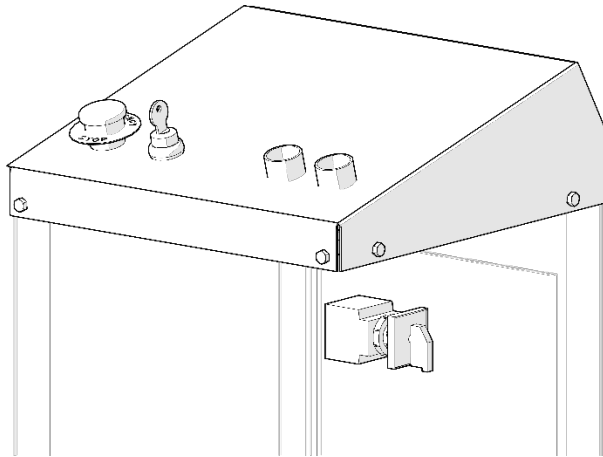

Drawing shows the Power Disconnect Switch on the right side of the Console.

Not all components shown.

Important: You are going to need to remove both the Top of the Console and the Front for Hose and Cable routing. See **Connect the Power Unit** for more information.

⚠ WARNING When accessing the Power Unit inside the Console for maintenance, do **not** use the Back Panel as the point of entrance; the Power Unit is mounted to the Back Panel. If the Back Panel is removed, the weight of the Power Unit may cause it to fall over and risk product damage and/or personal injury to anyone nearby.

6. Find the four holes in the bottom of the Console base (on the inside) and mark the locations.
7. Move the Console out of the way, then drill the holes 3/8" wide by 3" deep at the marked locations.

Do not let the drill wobble. Use a carbide bit (conforming to the current ANSI B212.15).

⚠ WARNING You **must** wear OSHA-approved (publication 3151) personal protective equipment at all times when installing, using, maintaining, or repairing the Autostacker: leather gloves, steel-toed work boots, eye protection, back belts, and hearing protection are **mandatory**.

8. Remove all dust from the Holes.
Use a wire brush, vacuum, hand pump, or compressed air. Do **not** ream the Hole. Do **not** make the hole any wider than the drill bit made it.
9. Reposition the Console, insert an Anchor Bolt with Washer into each hold, then tap it into the hole.
10. Wrench the Anchor Bolt **clockwise** to the recommended installation torque, 25-30 pound feet, using a Torque Wrench.



IMPORTANT! PLEASE READ NOW



Hydraulic Fluid Contamination

Hydraulic Fluid Contamination poses a **serious** issue for your Lift; contaminants such as water, dirt, or other debris can get into the Hydraulic Hoses and Fittings on your Lift, making your new Lift inoperable.

Your Lift is shipped with clean components; however, BendPak strongly recommends that you take secondary precaution and clean all Hydraulic Hoses and Fittings prior to making connections. It is better and less costly to take these extra steps now so that you do not need to take your Lift out of service later to fix issues that could have been prevented at the time of installation.

There are several ways to clean Hydraulic Hoses and Fittings:

- **Compressed Air.** Use an air compressor to blow out contaminants from each Hydraulic Hose and Fitting prior to installation. Clean, dry air is preferred. Wear eye protection (safety glasses, goggles, or face shield) when using compressed air for cleaning. Never point an air hose nozzle at any part of your body or any other person.
- **Fluid Flushing.** As long as the Hydraulic Fluid is clean and compatible with the system fluid, you can flush Hoses and Fittings to create turbulent flow and remove particulates. Always ensure that the fluid itself is contaminant-free.

Some additional steps that will help keep the Hydraulic Fluid clean:

- **Remove old thread seal tape.** Some ports on the Hydraulic Cylinders are shipped with temporary plugs secured with thread seal tape, so make sure to thoroughly remove any leftover thread seal tape that may inadvertently enter the Hydraulic System.
- **Use a liquid thread sealant only.** Teflon paste-type thread sealant or Loctite™ 5452 thread sealant is recommended for all NPT Fittings. Do not over tighten NPT Fittings or they may crack. Never use thread seal tape on JIC Fittings or ORB O-Ring Fittings.
- **Always use clean equipment.** If you use a dirty bucket or funnel to transfer the Hydraulic Fluid into the Hydraulic Fluid Reservoir, the contaminants will likely be introduced into the Fluid. When using cleaning rags, use a lint-free rag.
- **Proper storage.** Keep the Hydraulic Fluid sealed in its container until ready for use; store the Fluid in a clean, dry, and cool area.
- **Cover the Hoses and Fittings.** Before installation, do not leave the ends of the Fittings exposed; the same applies for the Hydraulic Hoses. As a general rule, keep the Hydraulic Hoses and Fittings capped and kept clean in a clean area until ready for use.
- **Filter the new Hydraulic Fluid.** Just because it is new does not necessarily mean it is *clean*. Use an offline filtration cart or kidney loop system to make sure the Hydraulic Fluid is clean before being transferred into the Hydraulic Fluid Reservoir (even using a heavy duty nylon mesh screen is better than trusting what is left at the bottom of the barrel).
- **Avoid mixing different types of Hydraulic Fluid.** If Hydraulic Fluid needs to be replaced, make sure to flush the Hydraulic System of the old Hydraulic Fluid before you add the replacement Fluid; do not mix the two together.

About Thread Sealants

Your Autostacker comes with a 4 ounce Bottle of Liquid Thread Sealant.

Liquid Thread Sealant lubricates and fills the gaps between the Fitting threads, and leaves no residue that could contaminate the Hydraulic Fluid. Other types of Thread Sealants (like Teflon Tape) can shred during installation or removal and eventually enter the Hydraulic System.

Thread Sealant is not the same as *Threadlocker*, Threadlocker holds assemblies tightly in place to prevent them from loosening over time, and is not easily removed.

Thread Sealant can be used with most Hydraulic Fittings, although you probably only need to use it with NPT connectors.

To apply Thread Sealant:

1. Make sure the Fittings and connectors you are going to use are clean and dry.

If you are adding Thread Sealant to a Fitting or connector that has already been used with a different sealant, use a wire brush to thoroughly remove the old sealant before adding more.

2. Apply a small amount of Thread Sealant to the first four threads of the Fitting.

 **WARNING** Always wear the proper protective equipment when handling Thread Sealant.

You only need a small amount because the sealant spreads to the other threads as it is tightened into place.

If you put too much, the excess liquid will be pushed out when the Fitting is tightened; use a rag to wipe the excess.

3. Tighten the Fitting into the connector; do **not** over tighten the Fitting.
4. Allow the manufacturer-recommended curing time before pressurizing the system.

Connect the Hydraulic Hoses

Both Hydraulic Hoses are routed through the Bottom Connector Tube, which is hollow.

If you have a Multi-Lift setup, this procedure will be different for you, see **Multi-Autostacker** towards the end of this manual for modified instructions.

The following drawing shows how the Hydraulic Hoses are routed to the Hydraulic Cylinders.

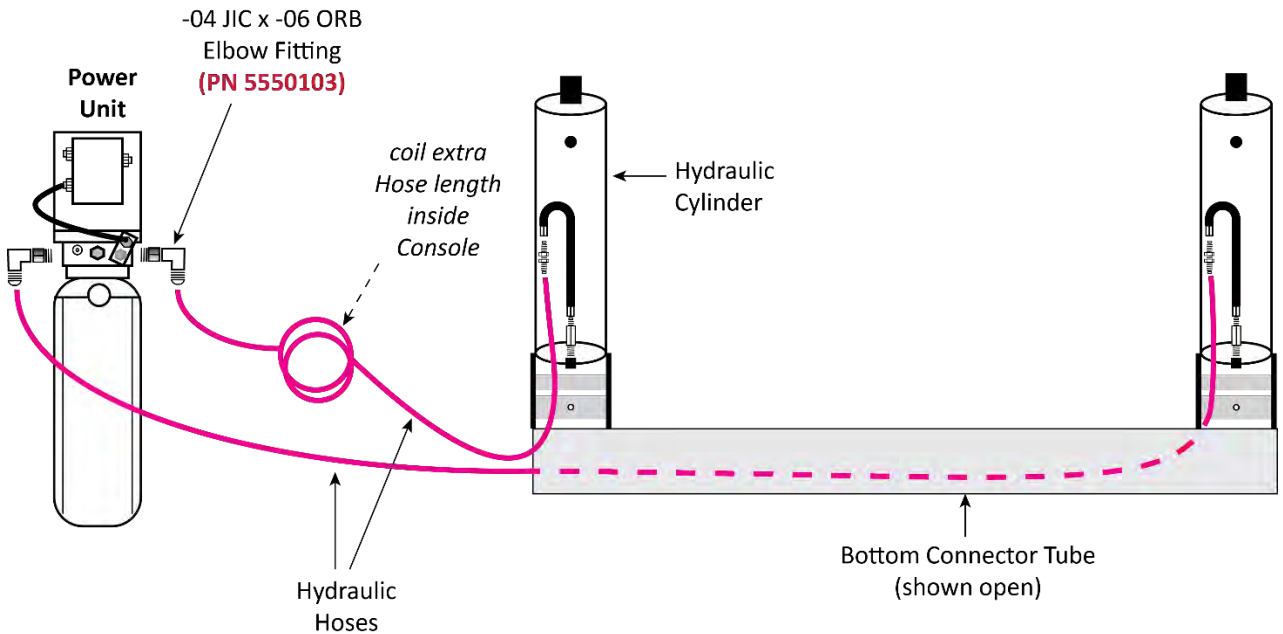

Not drawn to scale. Sample Power Unit shown, Console not shown. Hoses are routed through the Bottom Connector Tube.

The following drawing is a close-up of the connections to make to the Hydraulic Cylinders.

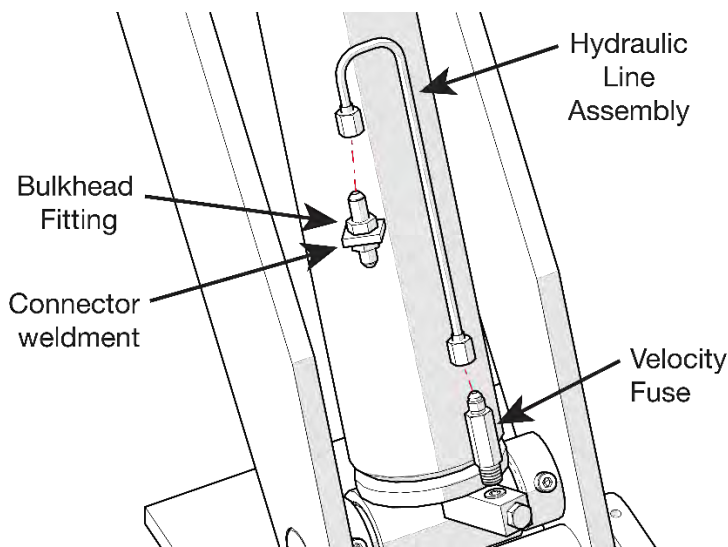

Not all components are shown.

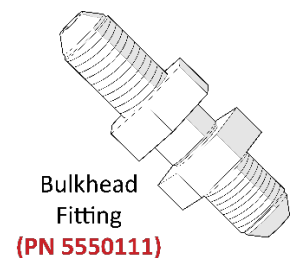

To connect the Hydraulic Hoses:

1. Locate the two Hydraulic Hoses that come with your Lift.

The two Hydraulic Hoses are the same length; it does not matter which Hydraulic Hose goes to which Hydraulic Cylinder on the Lift.

2. Starting near the Console, route both Hydraulic Hoses through the Bottom Connector Tube and pull it out at the Hydraulic Cylinder that is *furthest away* from the Console.

One Hydraulic Hose goes to the Hydraulic Cylinder that is closest to the Console, while the other Hydraulic Hose goes to the Hydraulic Cylinder that is furthest away from the Console.

Leave enough of the Hydraulic Hose on the Console end to allow the Hydraulic Hoses to be connected to the Power Unit up through one of the openings at the bottom of the Console.

Pull out enough of the Hydraulic Hose to reach the Bulkhead Fittings when it is time to put all of the components together.

3. On each Hydraulic Cylinder, install Velocity Fuses in the Ports near the bottom of each Hydraulic Cylinder. Finger tighten the connection.

Use Thread Sealant on NPT Threads only.

Refer to [About Velocity Fuses](#) for more information.

4. For both Hydraulic Cylinders, remove one Nut from the Bulkhead Fitting, put the Bulkhead Fitting into the Connector Weldment, put the Nut you just removed back onto the Bulkhead Fitting, and finger tighten both Nuts around the Connector Weldment.
5. For both Hydraulic Cylinders, connect the Hydraulic Line Assembly to the top end of the Bulkhead Fitting and the other end to the top end of the Velocity Fuse. Finger tighten the connections.
6. For both Hydraulic Cylinders, connect the Hydraulic Hose to the bottom end of the Bulkhead Fitting. Finger tighten the connections.
7. Attach two Elbow Fittings to both Hydraulic Pressure Ports on the Power Unit.

There are two Hydraulic Pressure Ports on a Power Unit, in varying locations (depending on the Power Unit you have). Refer to [Connect the Power Unit](#) to identify your Power Unit layout.

8. Route the two Hydraulic Hoses, one at a time, through an opening along the bottom of the Console and up to one of the Elbow Fittings, then connect them. It does not matter which Hydraulic Hose goes to which Hydraulic Pressure Port.

Coil any additional Hydraulic Hose length inside the Console.

9. Once all connections have been made, use the appropriate tools to fully tighten all of the finger-tightened connections.

Working with Return Lines and Compression Fittings

Autostacker uses Return Lines made of a roll of ¼ inch, polyethylene Tubing (also called Poly-Flo®) that is used with Compression Fittings to attach to the Air Cylinders and the Return Line Connectors.

The components involved with Compression Fittings include:

- **¼ inch, black, polyethylene Tubing.** The Return Lines require several lengths of tubing to make the necessary connections back to the Console.
- **Elbow Compression Fittings** (also called a 90° fitting). The Return Lines use Elbow Fittings to attach to each Hydraulic Cylinder and one that connects to the Console.
- **Tee Compression Fitting.** The two Return Lines hooked up to the Hydraulic Cylinders connect to a Tee Compression Fitting that goes back to the Power Unit.
- **Nuts, Ferrules, Rods, and Threads.** Each connector on Elbow and Tee Compression Fittings have a Nut, Ferrule, Rod, and Threads. The Nut holds the tubing and Fitting together. The Ferrule compresses when you tighten the Nut on the Threads to make a secure connection. The Rod goes inside the Tubing so that there are no leaks.

The following drawing shows the components of a connector on a Tee Compression Fitting

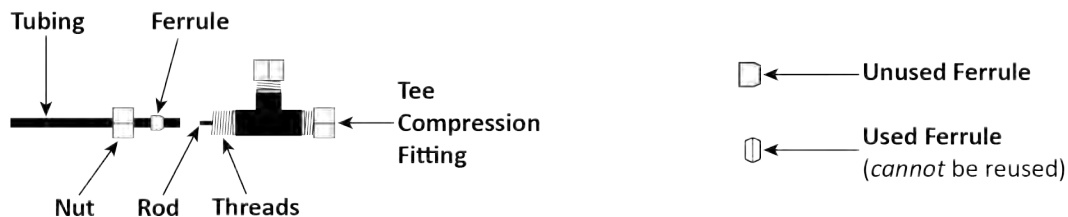

Important: ***Ferrules can only be tightened once.*** When you tighten the Nuts on the Threads, the Ferrules get compressed; it changes shapes and **cannot** be used again.

Connect the Return Line

The Return Line takes extra Hydraulic Fluid from the Hydraulic Cylinders and returns it to the Power Unit's Hydraulic Fluid Reservoir; it also allows air to move in and out of the Hydraulic Cylinders.

One end of the Return Line connects to the Power Unit (where it goes into the Reservoir). There are two other ends; they attach to Return Line Connectors, which are near the top of each Hydraulic Cylinder.

The Return Line comes as one long roll of tubing; you need to cut it into sections of the right length.

If you have a Multi-Lift setup, this procedure will be slightly different for you, see **Multi-Autostacker** for modified instructions.

The following diagram shows how the Return Lines should be arranged.

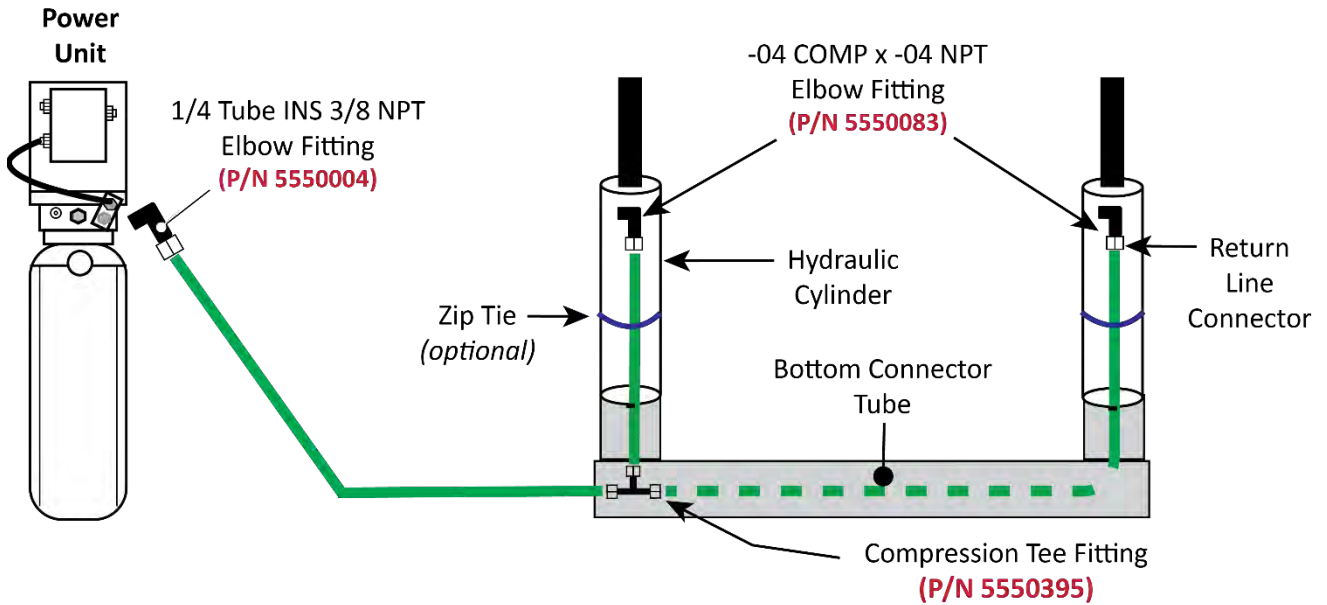

Not drawn to scale. Sample Power Unit shown. Power Unit goes inside the Console. Not all components shown for clarity. Return Line is routed through the Bottom Connector Tube.



Tip

If you want, you can use zip ties (also called cable ties, not supplied) to hold the Return Lines in place once they are connected.

To connect the Return Line:

1. Attach an Elbow Fitting to one of the two Return Line Ports on the Power Unit.

Use Thread Sealant with NPT Threads only.

There are two Hydraulic Return Ports on the Power Unit; they work the same, so choose the one that is best for you. **You only need to use one, not both.** They are shown in the drawing in **Connect the Power Unit**.

2. Attach an Elbow Fitting to both Return Line Connectors near the top of each Hydraulic Cylinder.

Use Thread Sealant with NPT Threads only.

3. Locate a Tee Fitting and put it near the bottom of the Hydraulic Cylinder closest to the Console.
4. Locate the Return Line tubing and cut the appropriate lengths for each of the three Return Line segments.
5. Connect a Return Line between the Power Unit and the Tee Fitting.
6. Connect a Return Line between the Tee Fitting and the Return Line connector on the Hydraulic Cylinder nearest the Console.
7. Connect the final Return Line to the Tee Fitting, route it through the Bottom Connector Tube, then connect it to the Return Line connector on the Hydraulic Cylinder furthest from the Console.

Connect the Power Unit

The Power Unit comes assembled from the factory. You need to attach it to the back of the Console and then make the proper connections.

If you have a Multi-Lift setup, this procedure will be different for you, see **Multi-Autostacker** for more information.

The Power Units that can be used with your Autostacker include either 110 VAC, 220 VAC at 50/60 Hz, 1 Ph or 380 VAC at 50 Hz, 3 Ph.

⚠ DANGER All wiring **must** be performed by a licensed, certified Electrician.

Refer to **Wiring Diagrams** for wiring information.

⚠ CAUTION The Power Unit's motor is **not** thermally protected.

The Power Unit has multiple connections:

- **Two Hydraulic Hoses and One Return Line.** Already in place and connected.
- **Power Cable.** The Power Cable on the Power Unit connects to the top of the Power Disconnect Switch. A licensed, certified Electrician is required for this connection.
- **Power Source.** The Power Source connects to the bottom of the Power Disconnect Switch. Also requires a licensed, certified Electrician.
- **Controls.** The Female (Molex™) Connector on the Power Unit connects to a Male Connector coming down from the Controls in the Top of the Console.

The following diagram shows a sample Autostacker Power Unit.

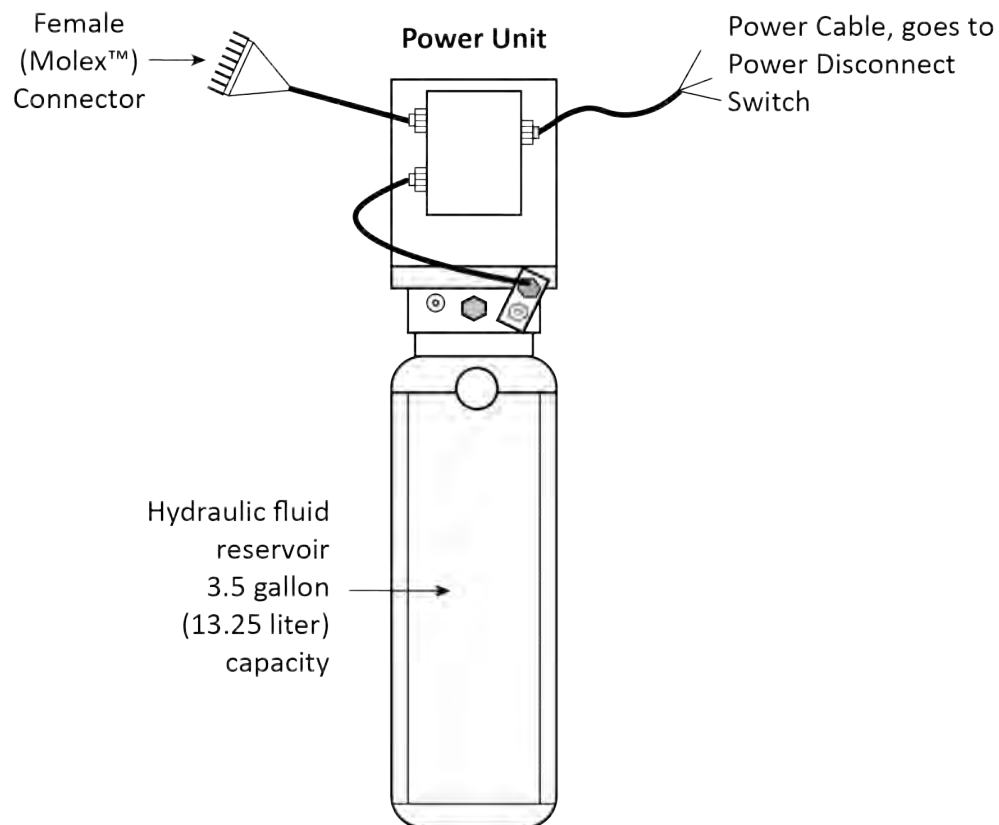

Depending on your Power Unit, the connector locations may be different. Use the drawing below to identify your layout and then attach your Hydraulic Hoses and Return Line appropriately.

⚠ CAUTION The Hydraulic Power Ports are almost always labeled **P1/P2**; the Hydraulic Return Ports are commonly labeled **T1/T2** or **CV1/CV2**. Do not accidentally attach a Hydraulic Hose to the Return Line Port. Your Autostacker will not work right unless the Hydraulic Hoses and the Return Line are attached to the correct connector.

The following drawing shows the possible configurations for your Power Unit.

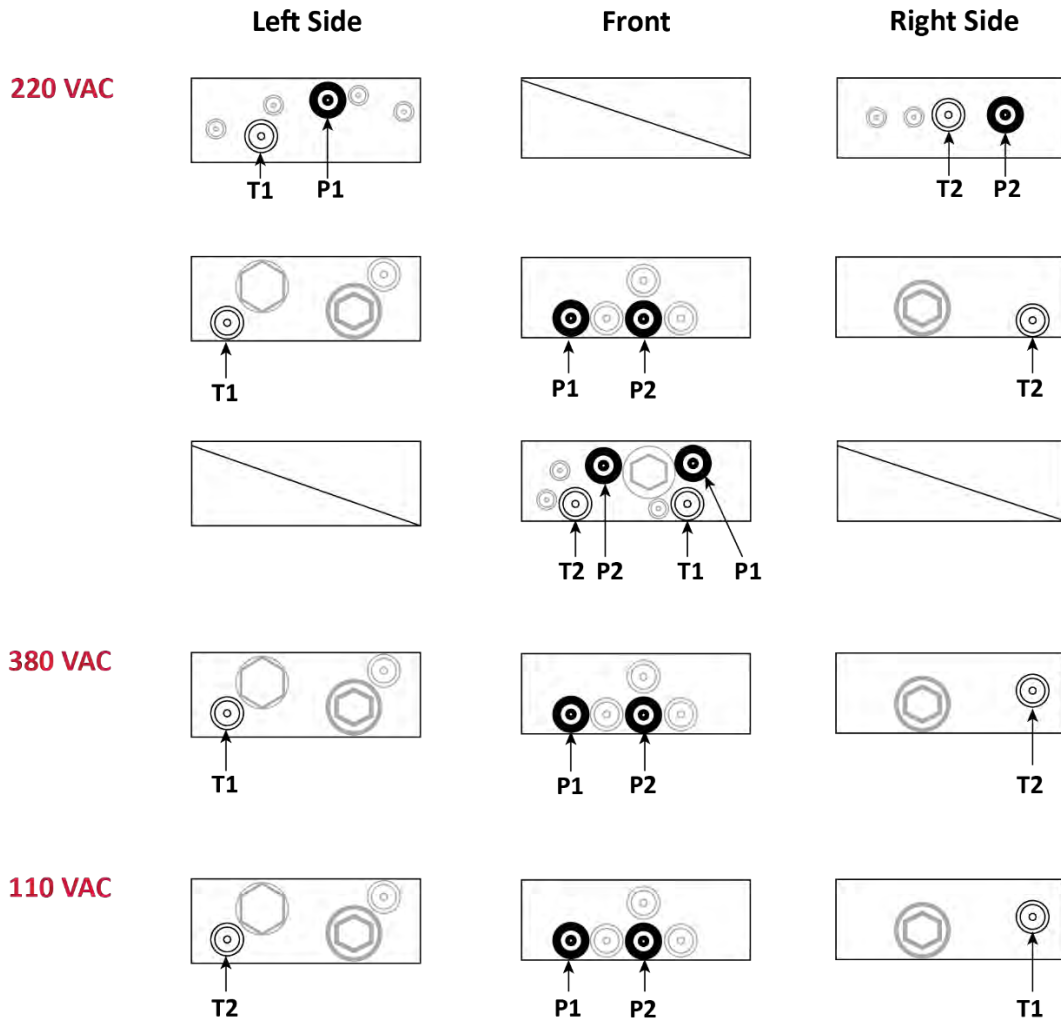

Not to scale. Not all components of the Power Unit shown.

To make connections to the Power Unit and add Hydraulic Fluid:

1. Remove the Top and Front of the Console if they are currently in place.
2. Locate the Female (Molex™) Connector on the Power Unit and attach it to the Male Connector that comes from the Controls in the Top of the Console.

Make sure to orient the two Connectors correctly.

3. Have an Electrician connect the Power Cable on the Power Unit to the **top** of the Power Disconnect Switch, and then connect your selected VAC power source to the **bottom** of the Power Disconnect Switch.

Refer to **Wiring Diagrams** for proper wiring information. Note that the cord from the power source to the bottom of the Power Disconnect Switch is **not** supplied.

⚠ DANGER All wiring **must** be performed by a licensed, certified Electrician. Do not perform **any** maintenance or installation on the lift without first making sure that main electrical power has been disconnected from the lift and **cannot** be re-energized until all procedures are complete.

Important electrical information:

- Improper electrical installation can damage the Power Unit motor; this damage is not covered under warranty.
 - Use a separate circuit breaker for each Power Unit.
 - Protect each circuit with a time-delay fuse or circuit breaker.
 - For a 220 VAC, single phase circuit, use a 25 amp or greater fuse.
 - For a 380 VAC, three-phase circuit, use a 20 amp or greater fuse.
 - Position the Power Unit near the circuit breaker and incoming power source; for Power Units placed at a larger distance away, consult your Electrician.
 - Use the proper wire size for your Power Unit.
 - For 220 VAC, 50 Hz, 1 Ph or 208-230 VAC, 60 HZ, 1 Ph, 2 HP, use a minimum 12 AWG wire.
 - For 380 VAC, 50 Hz, 3 Ph, 2 HP, use a minimum 12 AWG wire.
 - For 110 VAC, 50/60 Hz, 1 Ph, use a minimum 10 AWG wire.
4. Have an Electrician check all connections for loose wiring.
 5. Fill the Hydraulic Fluid reservoir.

The Power Unit's Hydraulic Fluid reservoir must be filled with Hydraulic Fluid or Automatic Transmission Fluid **before** you begin operation. When you receive it, the reservoir is empty; the Power Unit will not work correctly until it is filled with approved fluids.

Approved fluids are any general purpose ISO-32, ISO-46, or ISO-68 hydraulic oil or approved automatic transmission fluids such as Dexron III, Dexron VI, Mercon V, Mercon LV, or any synthetic multi-vehicle automatic transmission fluid.

⚠ WARNING Do not run your Power Unit without Hydraulic Fluid; you will damage it. Keep the Power Unit dry; damage to the Power Unit caused by water, detergents, acid, and other liquids is not covered by the warranty.

Wiring a Power Disconnect Switch

⚠ DANGER All wiring **must** be performed by a licensed, certified Electrician. Do not perform **any** maintenance or installation on the Lift without first making sure that main electrical power has been disconnected from the lift and **cannot** be re-energized until all procedures are complete.

⚠ WARNING User-supplied wiring connects to the wiring **inside** the Electrical Box; remove the front cover to access the inside. Do not accidentally connect to the electrical components on the underside of the Console Top.

The following diagram shows the components related to installing a Power Disconnect Switch.

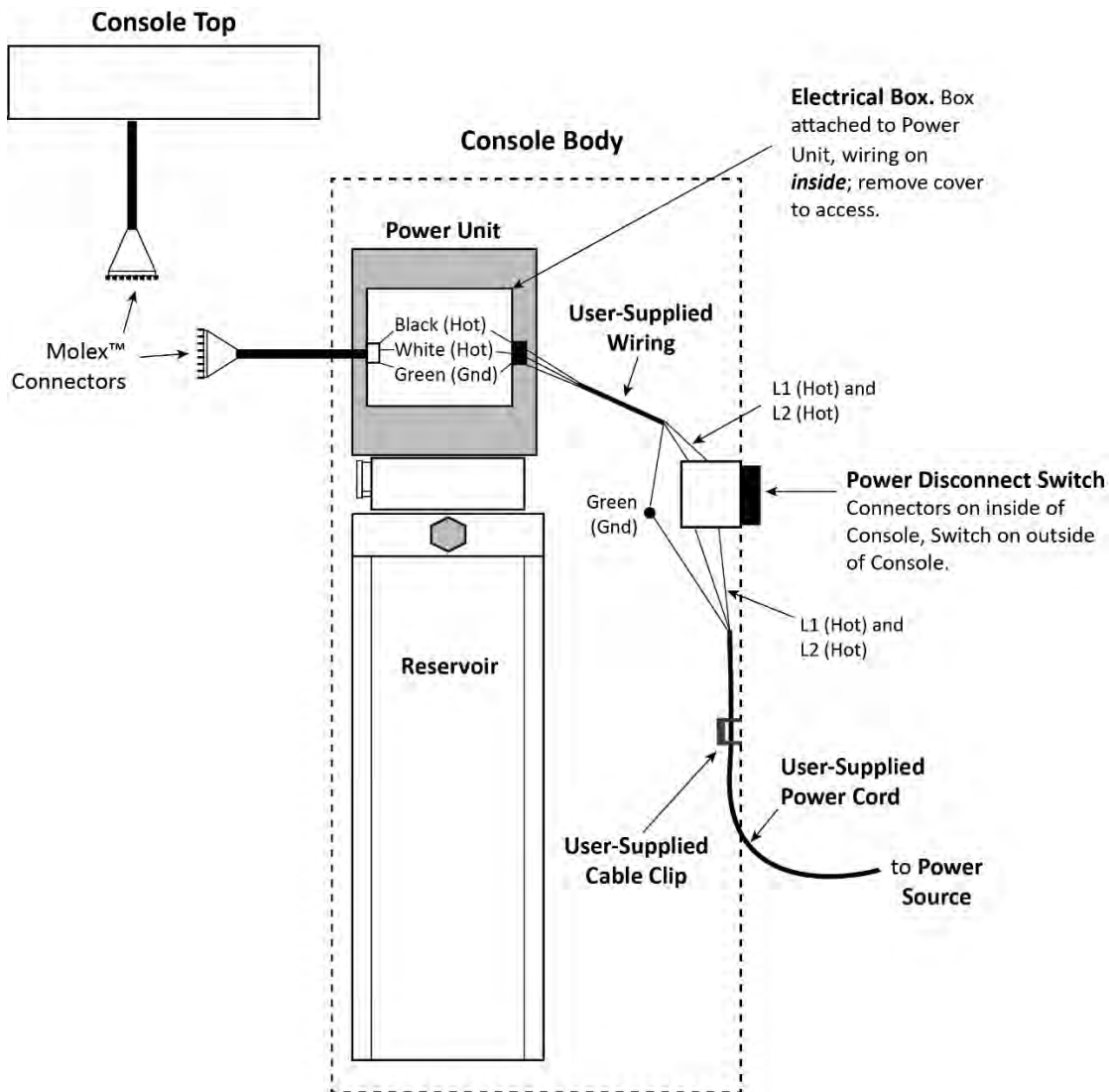

Drawing not to scale. Not all components shown. Only connect Molex connectors to each other.

⚠ DANGER Do not perform the following procedure until you are certain the Power Unit is disconnected from power and cannot be re-energized. All electrical work **must** be performed by a licensed, certified Electrician. If your organization has Lockout/Tagout policies, make sure to implement them after connecting to a power source.

To install the Power Disconnect Switch on an Autostacker:

1. Remove the two screws from the sides of the Electrical Box and remove the cover.
2. Locate the three available wires: Black (Hot), White (Hot), and Green (Ground).
3. Connect the three available wires to a User-supplied wiring.
4. Connect the two Hot wires, Black and White, to the top of the Power Disconnect Switch.
5. Route the Green (Ground) wire around the Power Disconnect Switch to the User-Supplied Power Cord.
6. Attach the Brown (Hot) and Blue (Hot) wires in the User-Supplied Power Cord to the bottom of the Power Disconnect Switch.
7. Replace the cover of the Electrical Box and screw it back on.
8. Attach a Cable Clip to the inside of the Console, to hold the Power Cord securely; Cable Clips also help support the weight of the Power Cord.
Cable Clips are *not* supplied with the Power Unit.
9. Connect the User-Supplied NEMA rated Power Cord to an appropriate power source.

Install a Thermal Disconnect Switch

⚠ WARNING The Autostacker comes with a **Power** Disconnect Switch, but the Autostacker motor has no **thermal** overload protection.

Have an Electrician connect a Thermal Disconnect Switch or overload device that will make sure the equipment shuts down in the event of an overload or an overheated motor.

⚠ DANGER Installing a Thermal Disconnect Switch **must** be performed by a licensed, certified Electrician. Do not perform **any** maintenance or installation on the lift without first making sure that main electrical power has been disconnected from the lift and **cannot** be re-energized until all procedures are complete.

High electrical current that exceed the motor's full load amps (FLA) rating may result in permanent damage to the motor.

Autostacker strongly recommends you **not** exceed the rated duty cycle of the Autostacker motor.

Test the Autostacker

Before putting your Autostacker into normal operation, we recommend breaking it in by raising and lowering it a few times. This will help you get a feel for how to operate it and also helps to get any residual air out of the hydraulic system.



Tip Residual air in the hydraulic system can cause the Autostacker to shake, move erratically, or squeak; this is normal. If it happens to you, do not worry; it will go away quickly as the Autostacker is self-bleeding.

Neither the Platform nor the Drive-On Ramp need to be installed to test the lift. You also do not need weight on the Lift.

Note: The Autostacker lowers a little slower with no weight on it.

To test your Autostacker:

1. Check the area around and above the Autostacker for obstructions.
Move them if you find any.
2. Insert the key and move it to the On position.
3. Press and hold **Up**.
4. Before reaching the first Safety Lock, release **Up**.
5. Press and hold **Down**.
6. When the Autostacker gets to the ground, it stops lowering; release **Down**.
7. Wait for one minute.

 **WARNING** The Power Unit is not a constant duty motor; it *cannot* be run continuously.

8. Repeat the process, this time raising the Autostacker just past the first Safety Lock.

You can tell when the Autostacker passes a Safety Lock: when the Lock Hood goes past a Lock Block, it hits the base and makes an audible click. Refer to **About Safety Locks** for more information.

9. If the Autostacker is working without shaking, moving erratically, or squeaking, there is no need to repeat the procedure.

If the Autostacker is shaking, moving erratically, or squeaking, repeat the procedure one more time, raising the Autostacker to the second Safety Lock.

It is normal for the Autostacker to shake, move erratically, or squeak when you first get it. Using it a few times almost always fixes those issues.

If your Autostacker continues to have problems well past the break-in period, refer to **Troubleshooting** for additional information.

Add the Tire Trough and Tire Stops

The Tire Trough is a lowered section of the Platform that holds the tires of the Vehicle. The Tire Stops attach to the top of the Tire Trough and add a bit of extra height for holding Vehicles with larger tires.

Important: The forward wheels of the Vehicle on the Platform must **always** be sitting fully in the Tire Trough.

⚠ WARNING The Tire Trough is heavy. Move it into position using a lifting device such as a Forklift or Shop Crane. If this is not an option, have at least two people to move it. **Do not allow just one person to move the Tire Trough**, they could be injured.

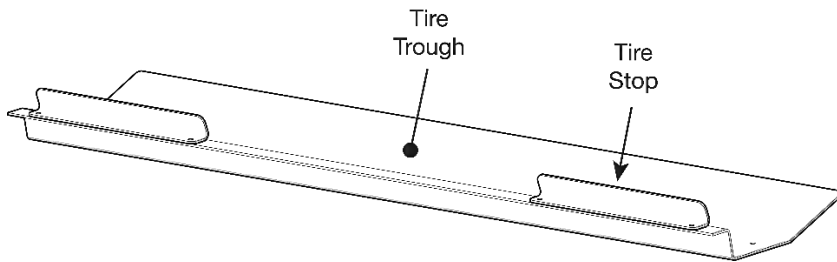

The Tire Stops attach to the top of the Top Trough, functioning as a Tire Chock. Not to scale.

To install the Tire Trough and Tire Stops:

1. Move the Tire Trough into position next to the Top Connector Tube.
A section of the Tire Trough rests on the Top Connector Tube. This is where the Tire Stops go and where you attach the Tire Trough to the Top Connector Tube.
2. Get the necessary Bolts (4), Nuts (4), and Washers (8) from the Parts Bag.
3. Put the Tire Stops on top of the Tire Trough; align the holes in the bottom of the Tire Stops with the holes in the Tire Trough and the Top Connector Tube.
4. Orient the Tire Stops so that the vertical portion is on the Tire Trough side, then secure the Tire Trough and Tire Stops in place, as shown below.

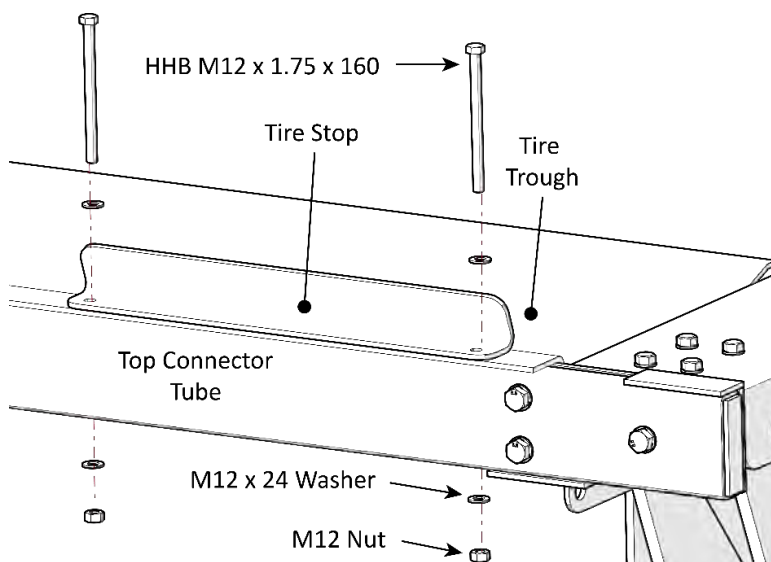

Drawing shows how to connect the Tire Stops and Tire Trough in place.

Not all components are shown.

5. Repeat Steps 4 and 5 for each of the other holes.

Add the Platform Sections and the Drive-Up Ramp

The Platform sections, when installed, create the Platform. The Drive-Up Ramp lets you drive a vehicle onto the Platform. The Platform sections are most easily installed from underneath. Raise the Autostacker to a height that is good for you.

⚠ WARNING Do not go under the Autostacker until it is securely on a Safety Lock.

When you get to the Drive-Up Ramp, it secures only on the sides, not in the middle.

To add the Platform sections and the Drive-Up Ramp:

1. Starting next to the Tire Trough, put a Platform section next to the Tire Trough and then slide the end closest to the Tire Trough under it slightly; bolt the ends of the Platform section into the Platform Arm.

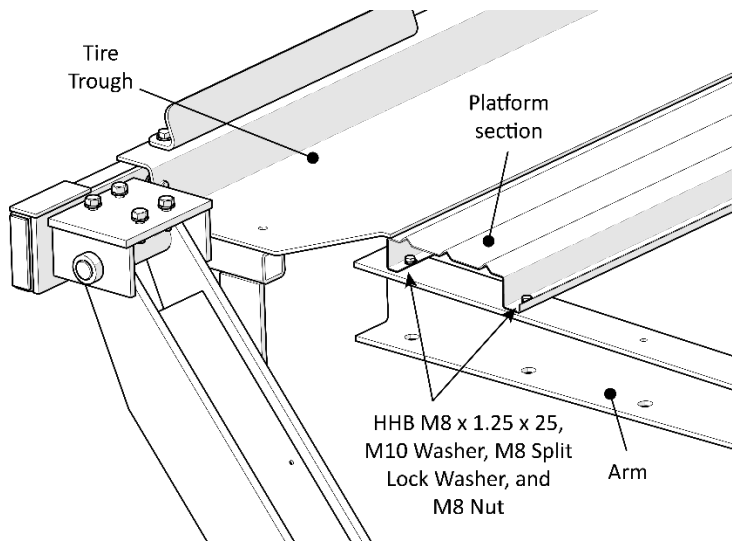

Top/Side view of Autostacker Arm. Graphic shows how to place the first Platform section just under the Tire Trough.

Some components stripped away in graphic for clarity.

2. Put the next Platform section into place against the first one.
You know the two are oriented correctly when the holes line up.
3. Attach the Platform sections to each other by putting in a Nut and Bolt in their center holes.
It is not necessary to put in all of the Nuts and Bolts now; wait until all of the sections are in place.

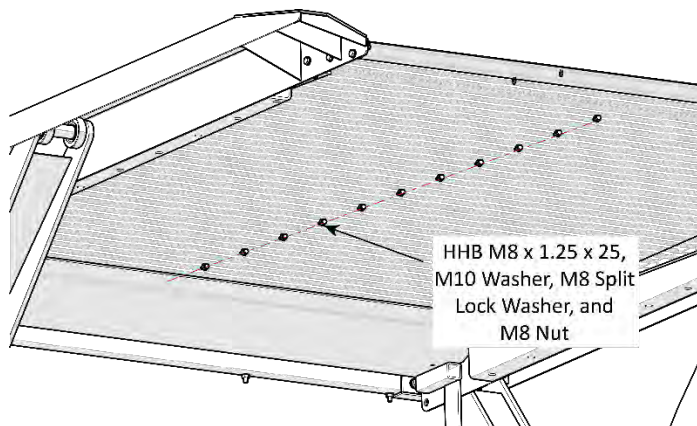

View is from underneath the Platform. Graphic shows the connections to make to the individual Platform sections.

Not all components are shown.

- When the last Platform section is in place, move the Drive-Up Ramp into place.
If it makes installation easier, you can lower the lift to a more appropriate height.

⚠ WARNING The Drive-Up Ramp is heavy. Move it into position using a lifting device such as a forklift or crane. If this is not an option, use at least two people to move it. **Do not allow just one person to move the Drive-Up Ramp**; they could be injured.

The end of the last Platform section and the top of the Drive-Up Ramp need to overlap.

- When the Drive-Up Ramp is correctly oriented, connect it to the Platform Arm using three Bolts, Washers, and Nuts on each side, as shown below.

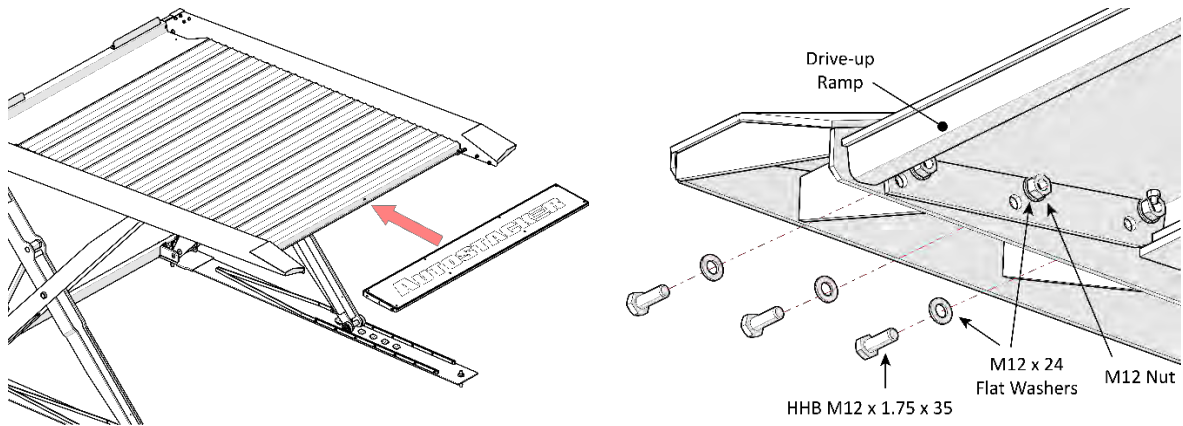

Left drawing shows the Drive-up Ramp being put into position, the right shows how to connect the Ramp to each Platform Arm.

- Make sure all of the Platform pieces and the Drive-Up Ramp are correctly positioned.
- Put in the rest of the Nuts and Bolts that attach the Platform sections to each other.
- Push the Rubber Edge up into place along the outside Rail of each Leg, at the Rear of the Lift, one Rubber Edge per Leg.

The Rubber Edges help in case you bump your head when passing underneath the Platform; they come in the Parts Box and are about 38 inches long.

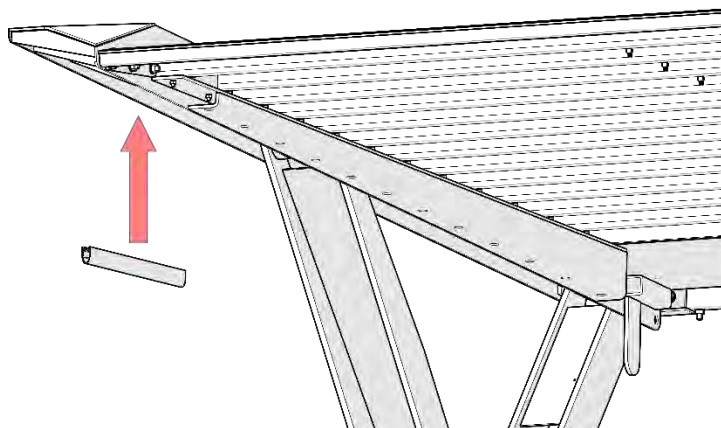

View is from the approach side of the Lift, underneath the Platform. One Rubber Edge per Leg.

Not all components are shown.

Lubricate the Lift

The Autostacker has eight Lubrication Points, four on each Leg Assembly. You must grease the Threaded Grease Fitting (P/N 5550025) at the Lubrication Points before you start normal operation of your Autostacker. Refer to **Maintenance** for more information.



Tip

Autostacker recommends using white lithium grease, or similar, and a grease gun with an appropriate tip (a Lube-Link™, for example) when lubricating your lift.

The Threaded Grease Fittings / Lubrication Points on each Leg Assembly are:

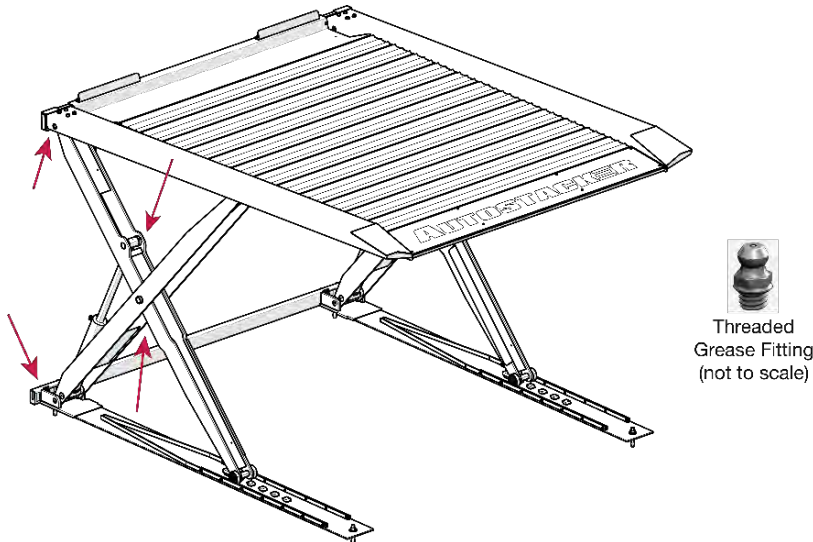

Final Checklist

Make sure these things have been done before using your Lift:

- Review the **Installation Checklist** to make sure all steps have been performed.
- Make sure the Power Unit is getting power from the power source.
- Check the Power Unit's Hydraulic Fluid reservoir; it must be full of approved Hydraulic Fluid or automatic transmission fluid. You can harm the motor by running it without enough fluid.
- Check the Hydraulic System for leaks.
- Check to see that all Anchor Bolts are properly tightened.
- Make sure that all Safety Locks are cleared and free.
- Make sure a copy of the *Installation and Operation Manual* is left with the equipment, so that it is available to all operators, and make sure all labels are visible.
- Raise the Autostacker to each of the six Safety Locks and measure the space between the ground and the bottom of the Drive-Up Ramp. Check these values against the values shown in **Raising a Vehicle**. These are the actual values that you should use to determine what Vehicles you want to put where.
- Perform an operational test of the Lift with a typical Vehicle.

During the operational test, observe all operating components and check for proper installation and operation. Do not raise any additional vehicles until a thorough operational check has been performed with a typical Vehicle.

If the Autostacker fails the operational test, take it out of service, then consult **Troubleshooting** to begin addressing the problem.

Operation

This section describes how to operate your Autostacker.

- ⚠ WARNING** Always use care when you are around the Autostacker. When it is lowered, be careful not to trip over it. When it is raised, be careful not to bang your head on the Drive-Up Ramp or Platform. **When the Autostacker is moving, keep all people, animals, and objects at least 30 feet away from it.**

Preparing to Raise or Lower a Vehicle

Before you raise or lower a Vehicle using Autostacker, do the following:

- **Check the Autostacker.** Check the Autostacker for any missing, heavily worn, or damaged parts. Do not operate the Autostacker if you find any issues; instead, take the Lift out of service, then contact your Autostacker dealer, visit autostacker.com/support, email support@autostacker.com, or call Autostacker at **(888) 977-8225**.
- **Check the area.** Check the area around the Autostacker for obstructions; anything that might block the Lift. Do not forget to check **above** the Autostacker. If you find an obstruction, move it out of the way. Do not allow people or animals within 30 feet of the Autostacker while it is in motion.
- **Check the operators.** Make sure that everyone who is going to operate the Autostacker has been trained in its use, has read the labels on the unit, and has read the manual. Only the operator at the Console should be within 30 feet of the Autostacker when it is in motion.
- **Check for safety.** Make sure everyone who is going to be walking near the Autostacker is aware of its presence and takes appropriate safety measures. Only put Vehicles on the Platform. **When raising the Autostacker, do not leave it until it is on a Safety Lock.** When lowering the Autostacker, do not leave it until it is on the ground. Do not allow children to operate the Lift. Do not allow anyone under the influence of drugs or alcohol to operate the Lift.

The Autostacker Console

Your Autostacker is controlled via its Console.



The parts of the Autostacker Console are:

- **Emergency Stop button.** Press to immediately stop the Autostacker from moving. This button is for use in unexpected or dangerous situations.
- **On/Off key.** Insert the key and turn it to On when you want to raise or lower the Lift. Set it to Off and remove the key when the Lift is not in use. **Do not leave the key in all the time;** this is a security and safety risk.
- **Up button.** Press and hold **Up** to raise the Lift. Release **Up** to stop the Lift from going up.
- **Down button.** Press and hold **Down** to lower the Lift. Release **Down** to stop the Lift from going down. The alert sound goes on automatically when the Lift is moving down.

About Safety Locks – Read Carefully before Operation!



Each Scissor Lift Arm has a Safety Lock and each Base has five welded Safety Lock positions. These Locks serve one important function and that is to keep you safe. Learning to recognize when the Autostacker is in a **LOCKED** and **UNLOCKED** condition is important to your safety.

Do not walk under your Autostacker or leave the area until you have confirmed that **both** Safety Locks are securely locked on a Stop Block. Although rare, it is possible for Hydraulic Fluid in the Cylinders to leak, causing the Lift to slowly lower.



WARNING

**NEVER LEAVE THE AUTOSTACKER IN AN UNLOCKED CONDITION!
Leave the Autostacker on the ground or on its Safety Locks ONLY!
There is ONLY ONE CORRECT LOCKED position for the Autostacker!**



WARNING

**FAILURE TO FOLLOW THESE INSTRUCTIONS CAN RESULT IN
PROPERTY DAMAGE, SERIOUS INJURY OR DEATH.**

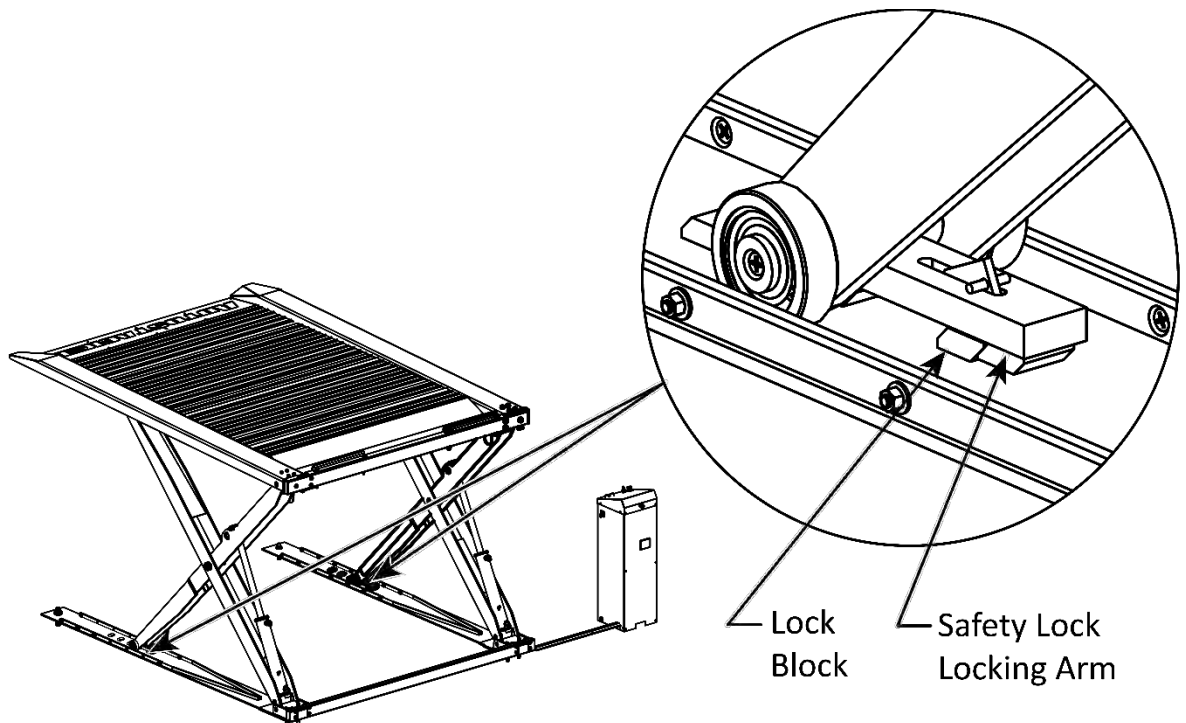

Safety in the LOCKED POSITION

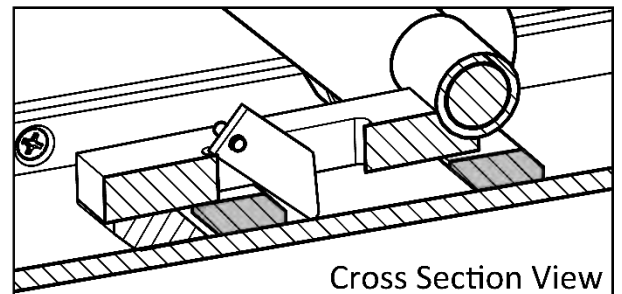
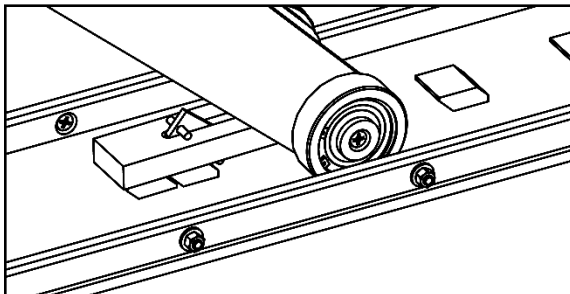

❌ NO! Safety NOT in LOCKED POSITION

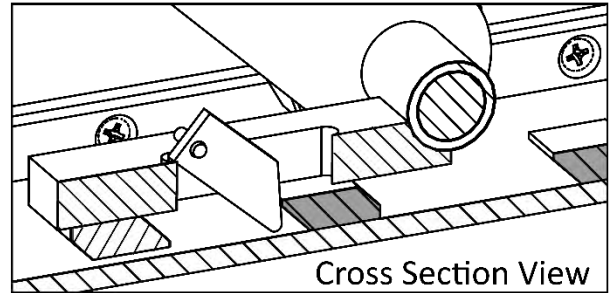
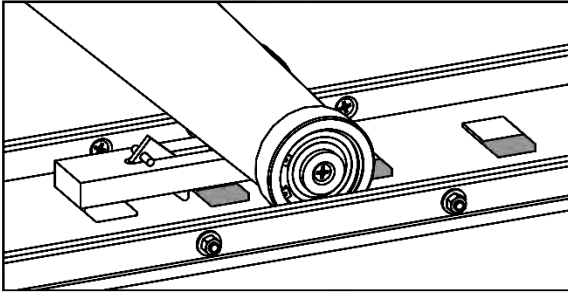

Cross Section View

❌ NO! Safety NOT in LOCKED POSITION

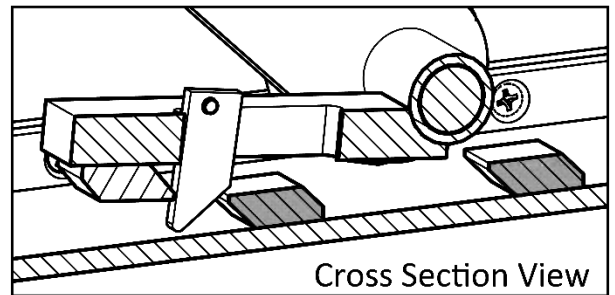
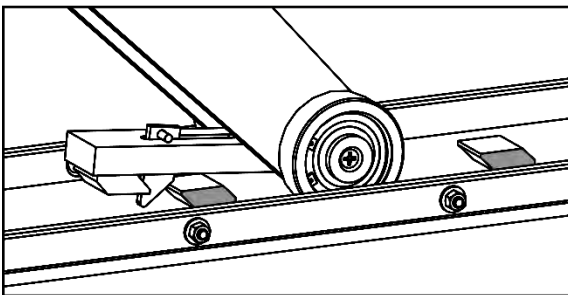

Cross Section View

❌ NO! Safety NOT in LOCKED POSITION

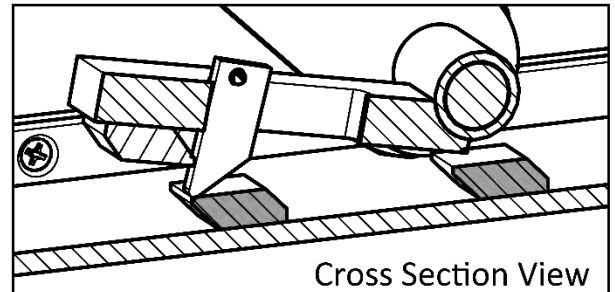
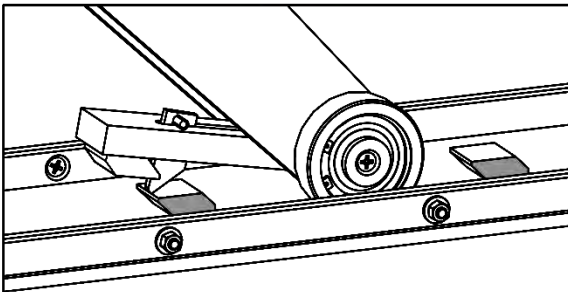

Cross Section View

❌ NO! Safety NOT in LOCKED POSITION

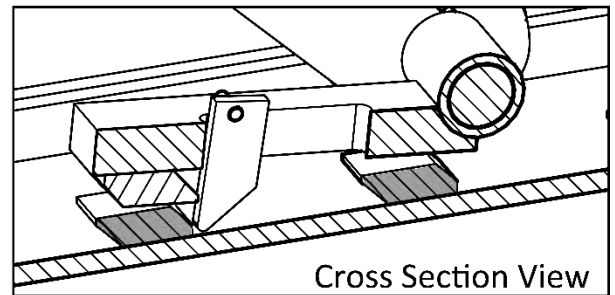
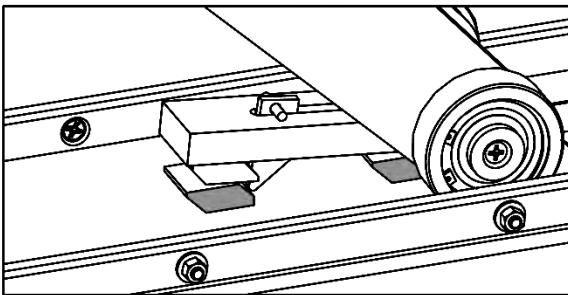

Cross Section View

Detailed description of the Safety Locks and their operation:

⚠ WARNING Keep the Bases of the Autostacker clean and free of debris that may interfere with the operation of the Safety Locks.

Safety locks mechanically hold the Lift Platform in place. Once your Autostacker is properly engaged on its Safety Locks, the weight of the Vehicle holds the Platform against the Safety Locks without requiring any hydraulic energy. If you turn the Power Unit off, if the power goes out, or the hydraulics develop a leak, the Safety Locks hold the Platform in place.

The figure below details the Autostacker in a **Locked Condition**.

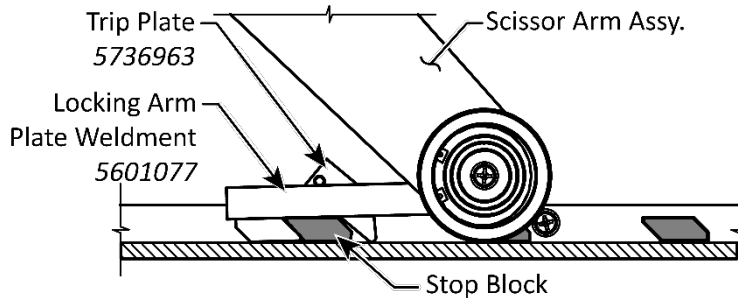

To move your Autostacker off of and onto a Safety Lock:

1. Beginning from the ground or the **locked** position pictured above, press the **Up** button to move the Platform up past one of the Lock Blocks. This action also moves the Safety Locking Arm and Trip Plate off of the Safety Block. Move the Platform **Up** until the Safety Lock Arm and Trip Plate move past a Stop Block.

The Autostacker is in an **Unlocked Condition**, detailed below.

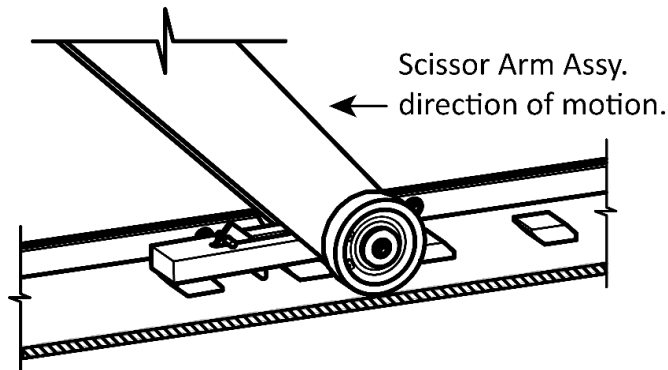

Not to scale. Some components removed for clarity.

2. Press the **Down** button to lower the Platform.

The cross-section below details the Trip Plate contacting the Stop Block.

The Autostacker is in an **Unlocked Condition**, pictured below.

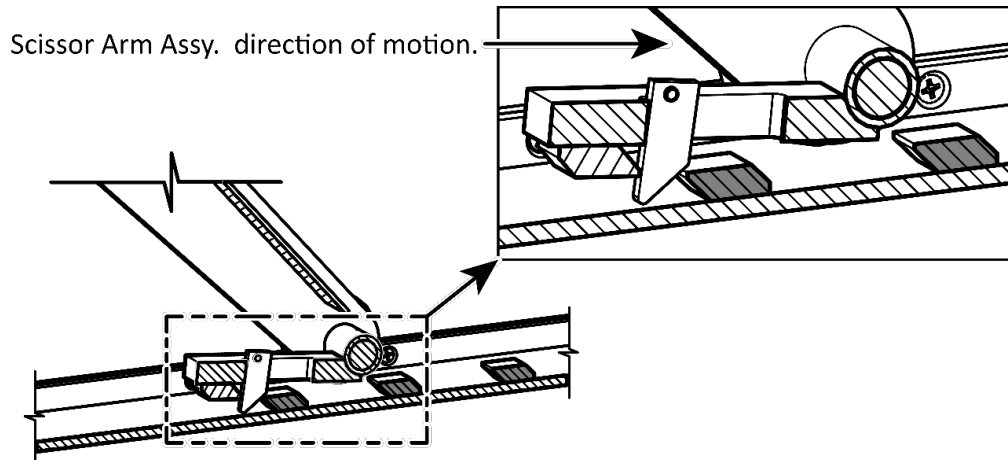

Not to scale. Some components removed for clarity.

3. Continue to press the **Down** button. The Trip Plate will force the Locking Arm to rotate up and over the Stop Block as the Scissor Arm moves.

The Autostacker is in an **Unlocked Condition** as pictured below.

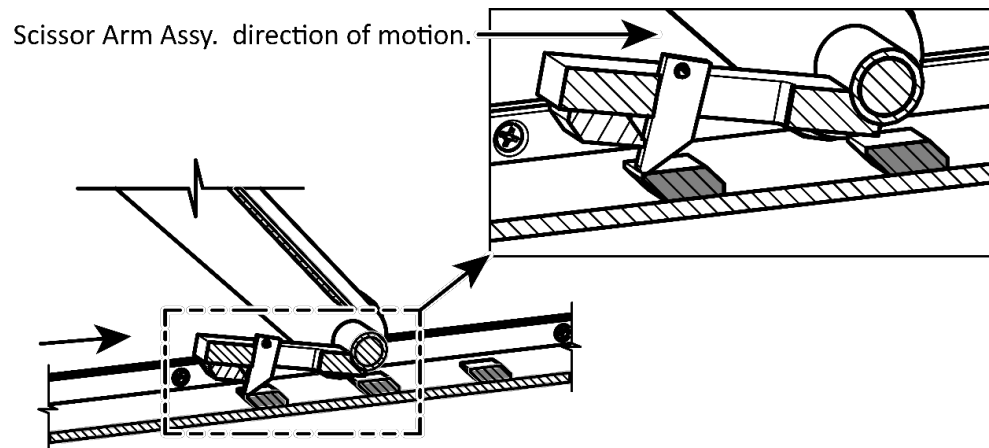

Not to scale. Some components removed for clarity.

4. Continue to press the **Down** button. When the Locking Arm and Trip Plate move past a Stop Block, it makes an audible **click** as it contacts the Autostacker Base.

IMPORTANT: With the Trip Plate in the position pictured on the next page, the Autostacker could move past **all** the Stop Blocks and be lowered to the ground.

The Autostacker is in an **Unlocked Condition**, pictured below.

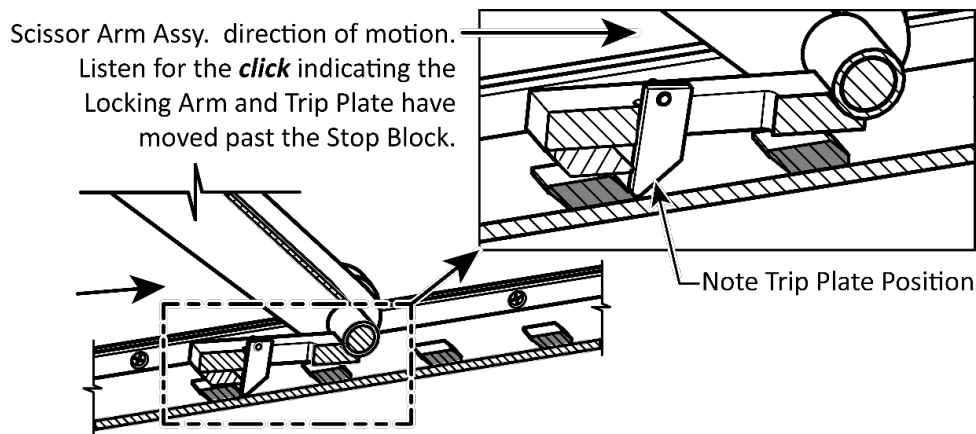

Not to scale. Some components removed for clarity.

5. Release the **Down** button, then press the **Up** button. The Autostacker Platform and Scissor Arms will reverse direction and the Locking Arm will rotate up and over the Stop Block.

IMPORTANT: Note the Trip Plate position. This position allows the Locking Arm to drop down to the Base putting it in a position to engage the Stop Block.

The Autostacker is in an **Unlocked Condition** as pictured below.

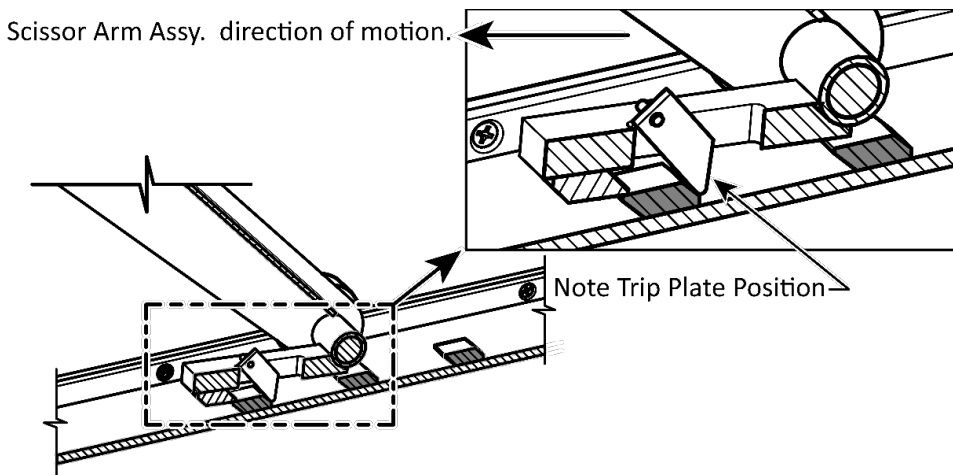

Not to scale. Some components removed for clarity.

6. Continue to press the **Up** button until the Locking Arm Drops down to the Base making an audible **click**, then release the **Up** button.
7. Press the **Down** button until the Locking Arm contacts the Stop Block and the Platform stops moving.

The Autostacker is now in a **Locked Condition**, detailed below.

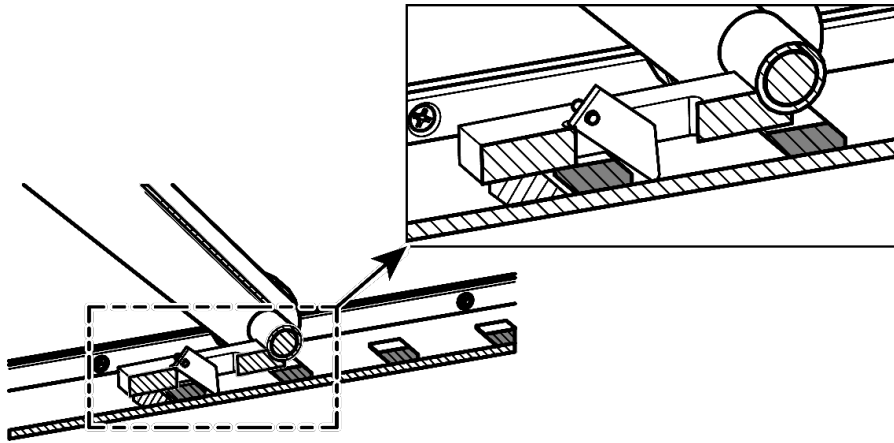

Not to scale. Some components removed for clarity.

⚠ WARNING: Do not walk under the Lift or leave the area until you have confirmed **both** Safety Locks are securely locked on a Stop Block. Failure to do so could result in product/vehicle damage and or personal injury.

Parking a Vehicle Under Autostacker

This section describes how to park a Vehicle under the Autostacker Platform.

To park a Vehicle under the Platform:

1. Check the height of the Vehicle against the amount of space that is available under the Autostacker Platform; there needs to be enough space to accommodate the height of the Vehicle.
2. If necessary, raise the Autostacker Platform to a higher Safety Lock.

If the Autostacker Platform is already on the highest Safety Lock, and there still is not enough space available, **you cannot park that particular Vehicle under the Autostacker Platform.**

If desired, lower the Vehicle's antenna and fold in any side mirrors.

3. Drive the Vehicle into the center of the space under the Autostacker Platform.
4. Put the Vehicle in park, engage the parking brake, and turn off the Vehicle.
If the Vehicle has a manual transmission, put it into first gear before turning off the Vehicle.
5. Open the car door(s) carefully, making sure not to strike the door against the Autostacker's Scissor Legs.

Although the Autostacker comes with Patented Door-Sentry™ car door protectors, you should always carefully open the car doors when exiting a Vehicle parked underneath the Platform.

6. Exit the Vehicle, taking care not to bump your head on the Autostacker Platform or trip over the Autostacker Bases.
7. To get the parked Vehicle back out again, simply reverse this process.

Lowering a Vehicle

This section describes how to move a Vehicle off the Autostacker Platform.

To lower a Vehicle:

8. Check the items listed in **Preparing to Raise or Lower a Vehicle**.
If you find any issues, resolve them **before** lowering the Vehicle.
9. At the Console, insert your key and turn it to the **On** position.
10. Press and hold the **Up** button to raise the Lift off of the Safety Lock Block.

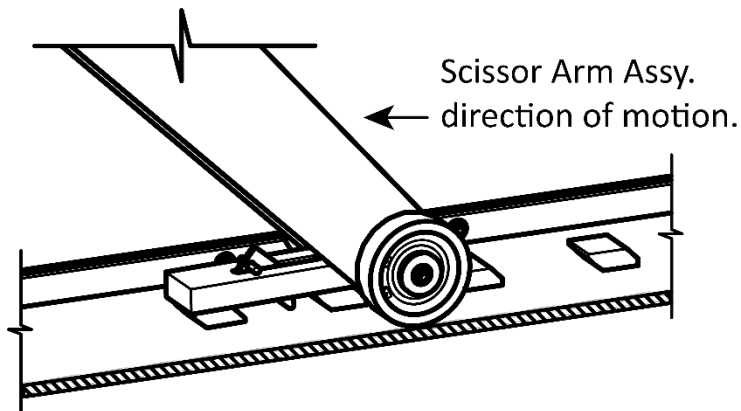

The Lock Plate and Lock Cam move nearly to the next Lock Block in order to disengage completely from the Safety Lock Block it was secured on.

11. Once disengaged from the Lock Block, the Trip Plate will be facing down, as shown above.
Press and hold the **Down** button.
12. When the Autostacker Platform is resting on the ground, release the **Down** button.
13. Carefully drive the Vehicle off the Autostacker Platform.
14. Turn the key on the Console to the **Off** Position, then remove it.

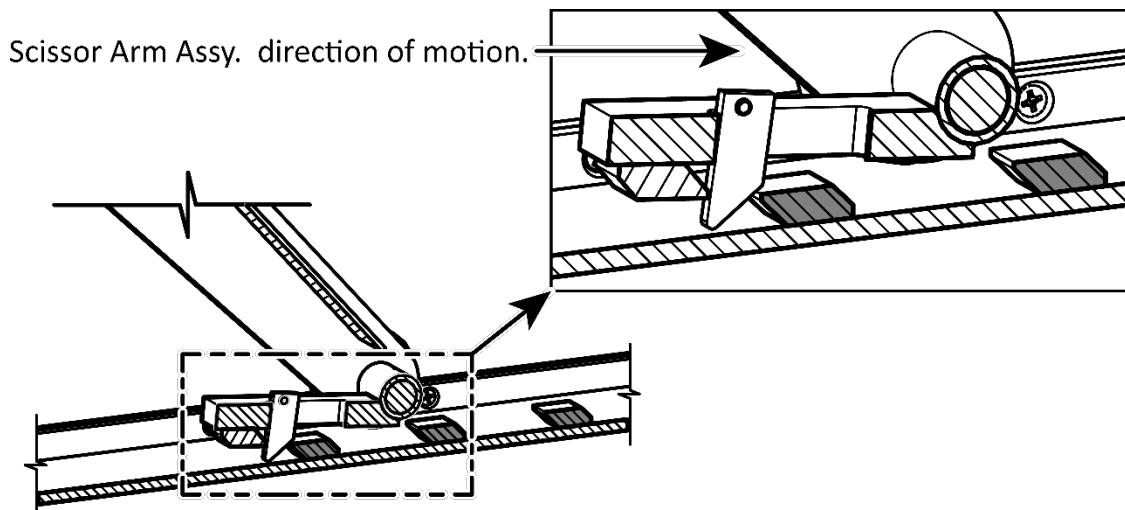

Raising a Vehicle

This section describes how to position a Vehicle on the Autostacker and raise it.

To raise a Vehicle:

1. Make sure the Platform is fully lowered, then drive the Vehicle onto the Platform.

 **CAUTION** When driving a Vehicle onto or off of the Platform, keep to the middle of the Platform. Also, be careful driving onto the Platform with a Vehicle that has wet tires, it can be difficult for the wheels to gain traction.

2. Put the Vehicle's forward wheels into the Tire Trough. The wheels **must** be in the Tire Trough.
3. Put the Vehicle in park, put on the parking brake, and turn off the Vehicle.

If the Vehicle is a manual transmission, put it into first gear before turning off the Vehicle.

4. Get out of the Vehicle and make sure the forward wheels are securely in the Tire Trough.

If the forward wheels are not situated correctly in the Tire Trough, get back into the Vehicle and reposition the wheels; the Rear Wheels **must** fit on the Platform or Drive-up Ramp.

5. Double check that there are no obstructions that will interfere with the raising of the Lift.
6. At the Console, insert your key, turn it to On, then press and hold the **Up** button.
7. Watch the Vehicle and the Lift as they rise.

If the Lift becomes unstable or the Vehicle starts moving on the Platform, press the red **Emergency Stop** button.

8. When the Platform passes the desired height, release the **Up** button.
9. Press the **Down** button to move the Lift down onto the most recently passed Safety Lock.



Tip If you move the Lift too far past a Safety Lock, it will **not** catch on the way back down. If this happens, simply move the Lift back up again, just past the Safety Lock, and then lower it back down onto the Safety Lock.

The Safety Lock heights are:

- **Top Safety Lock:** 81.25" / 6.9' / 2,066 mm of space under Platform
- **Second Safety Lock:** 75.25" / 6.3' / 1,911 mm of space under Platform
- **Third Safety Lock:** 68.5" / 5.9' / 1,741 mm of space under Platform
- **Fourth Safety Lock:** 61" / 5.1' / 1,549 mm of space under Platform
- **Lowest Safety Lock:** 52" / 4.4' / 1,326 mm of space under Platform

Using the top Safety Lock frees up more space for the Vehicle you are parking under the Platform; using the lowest Safety Lock frees up more space for the Vehicle you are parking on the Platform.

Note: Depending on the installation, these figures can vary 1/2 an inch in either direction. If your measurements indicate that your Vehicle is too close to these heights, raise the Lift to the next Safety Lock. If the Platform is already on the highest Safety Lock, and there is still not enough space available, **you cannot park that particular Vehicle underneath the Platform.**

About Velocity Fuses

Velocity Fuses are a safety feature. They stop hydraulic flow in the event of a Hydraulic Hose failure. Every Autostacker comes with one Velocity Fuse per Hydraulic Cylinder.

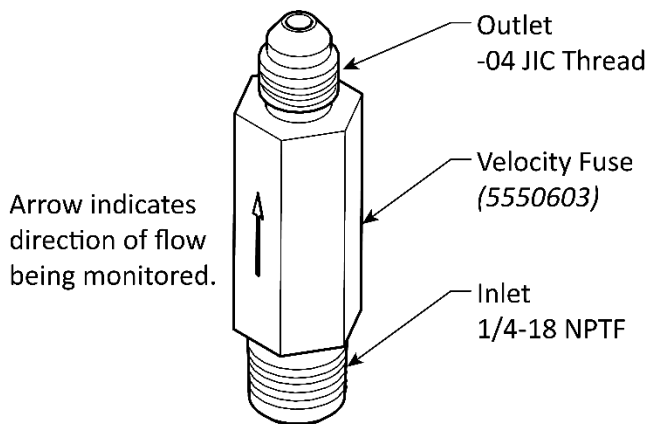

When the Platform is being raised, Hydraulic Fluid moves under pressure from the Power Unit to the Hydraulic Cylinder, which uses this force to raise the Platform. When the Platform is being lowered, Hydraulic Fluid moves back from the Hydraulic Cylinder to the Power Unit.

The Velocity Fuse monitors the flow of Hydraulic Fluid *back to the Power Unit*. The arrow on the Velocity Fuse shows the flow direction it is monitoring. The other direction is not monitored.

Most of the time, the force of the flow back to the Power Unit is beneath the trigger value of the Velocity Fuse. If, however, the Hydraulic Hose were to be accidentally cut, for example, the force of the flow back towards the Power Unit would increase significantly. If the force of the flow goes above the trigger value of the Velocity Fuse, the Velocity Fuse kicks in and blocks the flow thus stopping descent.

Outdoor Usage

Autostacker is designed for *indoor use*, so if you decide to use it outside, here's what you should know:

- **You may void your warranty.** Damages to the Motor or rusted components on the Lift caused by outdoor elements are *not* covered by warranty.
- **Cover the Lift.** Use a canopy or something similar to block the Lift from the sun and any precipitation, reducing the impact from it being outside.
- **Protect the Power Unit. *This one is really important.*** The Power Unit has an electric motor, so if that motor gets wet, it is possible for someone to get electrocuted, a fire can start, and most certainly the motor will short circuit and stop functioning. Always keep the Power Unit, Lift controls, and all electrical wiring covered, clean, and dry. For a Multi-Lift setup, make sure to keep the Master Power Unit and Control Stands protected and away from all sources of moisture.
- **Increased Maintenance.** Placing your Lift outside subjects it to the outdoor elements like wind, rain, dust, sunlight, snow, and other corrosive elements; you will need to double the maintenance on your Lift to minimize the impact from it being outside. For example, if the maintenance suggests doing something weekly, then do it 2-3 times a week.
- **Increased Replacement Parts.** Everything on the Lift breaks down faster if the Lift is outside, so be prepared to order replacement parts much sooner than with indoor Lifts.

Maintenance

Routine maintenance and adjustments should be carried out on a regular basis. For more complex maintenance and repairs, contact your independent maintenance contractor.

Routine maintenance and adjustments are the **responsibility of the owner/user** and are **not** covered under warranty.

⚠ DANGER: Before performing any maintenance on your Autostacker, make sure it is **completely disconnected from power**. If your organization uses Lockout/Tagout policies, make sure to implement them after connecting to a power source.

To maintain your Autostacker:

- **Daily:** Keep the Autostacker clean. Wipe up any spills, clean any dirt.
- **Daily:** Make a visual inspection of all moving parts and check for damage or excessive wear. Replace any damaged or worn parts before using the Lift.
- **Daily.** Check all Hydraulic connections for any leaks.
- **Daily:** Make sure Safety Locks are in good working condition. Do not use your Autostacker if the Safety Locks are damaged or excessively worn.
- **Twice a Week:** Sweep the Bases, removing all debris. Pay special attention to the Safety Locks and the wheel tracks; if these areas are dirty, the Lift may not work normally.
- **Weekly:** After cleaning the wheel tracks, apply a lubricant (WD-40®, for example) to the wheel tracks to help them roll easily. The wheels are self-lubricating.
- **Weekly:** Check all controls, including emergency stop, to make sure they are functioning normally.
- **Weekly:** Check all labels on the Autostacker. Replace them if they are illegible or missing.
- **Every Two Weeks:** Lubricate the Grease Fittings on the Lift.
- **Monthly:** Check the Hydraulic Fluid levels. Refill if low.

⚠ WARNING When accessing the Power Unit inside the Console for maintenance, do not use the Back Panel as the point of entrance; the Power Unit is mounted to the Back Panel. If the Back Panel is removed, the weight of the Power Unit may cause it to fall over and risk product damage and/or personal injury to anyone nearby.

- **Every Two Months:** Check all Bolts to make sure they are tight. If not, tighten them.
- **Every Three Months:** Damp wash all exposed surfaces to protect against corrosive debris.
- **Every Six Months.** Check the electrical wiring for loose connections; if you find any, secure them.

⚠ WARNING Do not operate your Autostacker if you find issues; instead, take it out of service, then contact your Autostacker dealer, visit autostacker.com/support, email support@autostacker.com, or call **(888) 977-8225**.

Troubleshooting

This section describes how to troubleshoot your Lift.

Note: If your Lift is not functioning correctly, you must take it out of service until it is fixed.

Important: All repair work **must** be done by qualified personnel.

Issue	Action to Take
Platform moves erratically or squeaks when in use.	Move the Platform up and down a few times, with a break between each; there could be residual air in the Hydraulic Hoses, also known as “self-bleeding”.
Platform does not go up or down.	Make sure there is sufficient Hydraulic Fluid in the reservoir. Make sure there is no air in the Hydraulic System. Make sure none of the Hydraulic Hoses are pinched or leaking. Make sure the Power Unit is getting power. If the Hydraulic Fluid is dirty, replace it with clean Hydraulic Fluid. Make sure lift is not overloaded. Lowering Valve may be clogged. Remove the valve, then check the valve opening for blockage; clear blockage if found.
Hydraulic Fluid is dirty.	Replace the dirty fluid with clean, approved Hydraulic Fluids, such as Dexron III, Dexron VI, Mercon V, Mercon LV, Shell Tellus S4 / S3 / S2, or comparable.
Lift makes odd noises.	Lubricate hinge points using white lithium grease.
The Platform is slowly lowering.	Make sure the Lift is on a Safety Lock (if not, Hydraulic Fluid could be leaking out, lowering the Platform).
Motor not running.	Check connection to power source. Check the wiring diagram.

If your Autostacker continues to have issues, contact your Autostacker dealer, visit [autostacker.com/support](https://www.autostacker.com/support), email support@autostacker.com, or call **(888) 977-8225**.

Optional Access Panel

The Access Panel gives you access to the underside of the Vehicle that is raised on an Autostacker; you can install up to two Access Panels per Autostacker.

An Access Panel is made up of two pieces:

- **The Structure.** Is bolted to the Lift in place of three Platform sections. Holds the Removable Panel.
- **The Removable Panel.** Sits in the Structure. Remove to access the underside of a Vehicle parked on the Platform. Dimensions are 35 inches by 53 inches.

⚠ WARNING: The Removable Panel does not take up the entire width of the Platform; when parking a Vehicle on the Platform, try to keep the tires off the Removable Panel — keep them on the Structure instead.

The following image shows the major parts of the Access Panel.

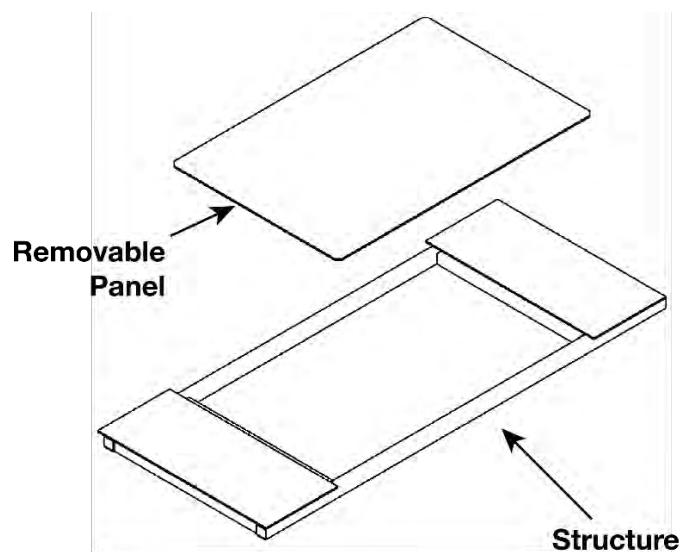

To install an Access Panel:

1. If you have already installed the Platform sections, remove them.
2. Put the Access Panel in the general location where you want it.
3. Starting next to the Tire Trough, put a Platform section next to the Tire Trough and then slide the end closest to the Tire Trough under it slightly.
4. Keep adding Platform sections the same way until you get to the Access Panel.
5. Move the Access Panel next to the last Platform section you added, then slide the end closest to the Platform section under it slightly.
6. Add the remaining Platform sections.

Each Access Panel takes the place of three Platform sections.

7. When the last Platform section is in place, move the Drive-Up Ramp into place.

The end of the last Platform section and the top of the Drive-Up Ramp **must** overlap.

 **WARNING** The Drive-Up Ramp is heavy. You should move it into position using a lifting device such as a Forklift or Shop Crane. If this is not an option, use at least two people to move it. **Do not allow just one person to move the Drive-Up Ramp**; they could be injured.

8. Check to make sure all of the Platform pieces and the Drive-Up Ramp are correctly positioned.

Multi-Autostacker

Autostacker is available in a Multi-Lift configuration where you can control up to 12 Lifts with one Master Power Unit; however, only **one** Lift can be raised or lowered at a time.

The installation for each Autostacker in a Multi-Lift setup is similar to that of a single Autostacker. The main differences include separate procedures for routing the Hydraulic Hoses and the Return Line to a Master Power Unit, in addition to installing a Control Stand **for each Lift** that allows you to operate a specific Autostacker in your setup. The following pages describe those procedures.

For a Multi-Lift setup, you will need the following:

- **Autostacker Lifts.** You decide how many Lifts (up to 12) you want in your setup.
- **Control Kits.** Connects the Control Stand and Hydraulic Hoses to the Lift. One Kit per Lift.
- **MPU (Master Power Unit).** Provides the Hydraulic force needed to operate the Lifts. One MPU for up to 12 Lifts.
- **MPU Plumbing Kit.** Connects the Master Power Unit to the first Lift. One Kit total.
- **MPU Enclosure.** *Optional, not included.* Protects the Power Unit from the outdoor elements.

The following drawing shows the Control Stands at the Front of the Lifts.

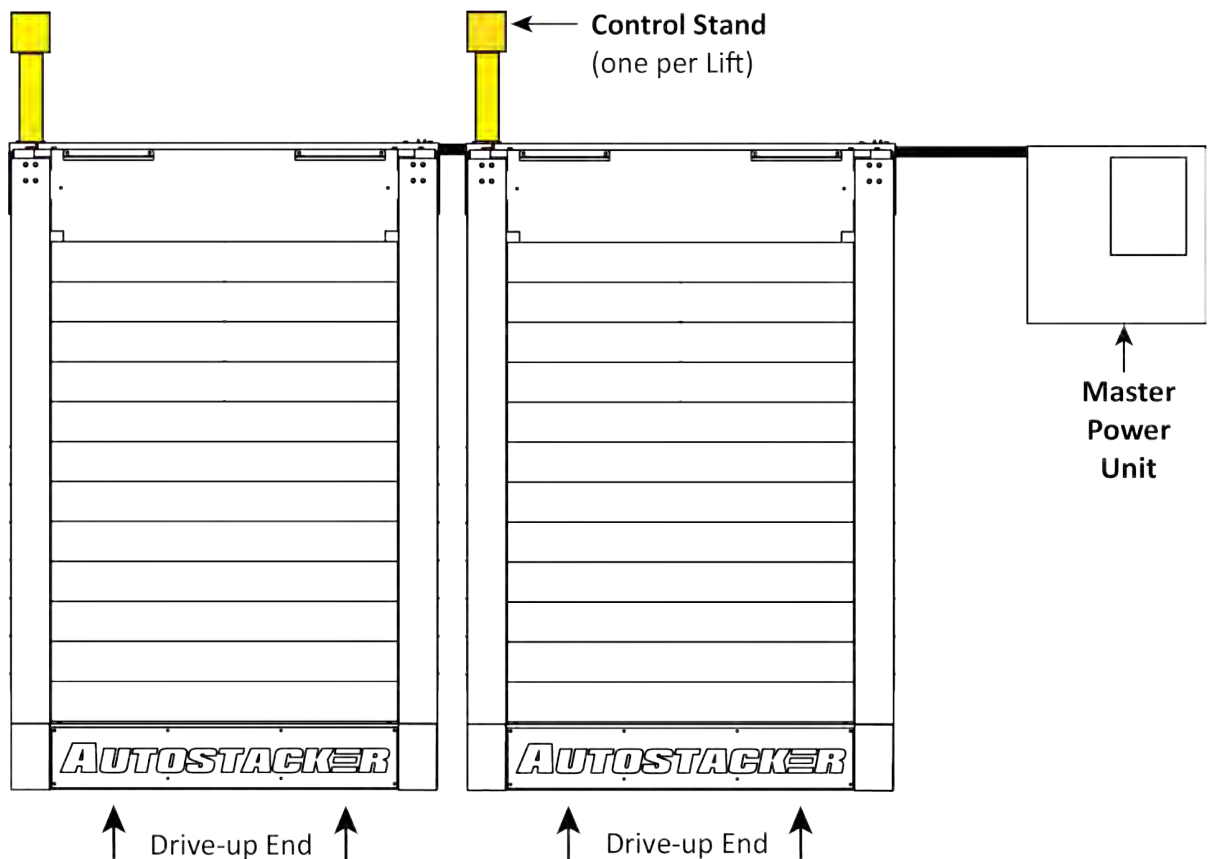

Not necessarily to scale. Not all components are shown. The Front of the Lift is where the Front of the Vehicle commonly rests once driven onto the Platform.

Specifications

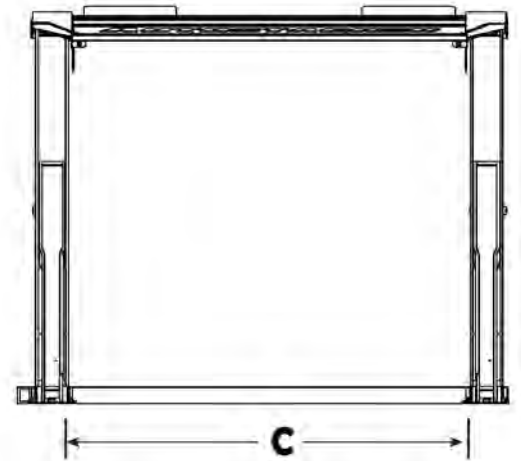
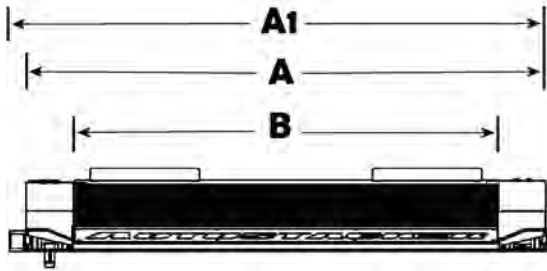

Control Stand – Front of the Lift	A-6S	A-6W
A Total width	103" (8.6 feet) / 2,616 mm	111" (9.3 feet) / 2,815 mm
B Platform width	83.75" (7 feet) / 2,127 mm	91.75" (7.7 feet) / 2,331 mm
C Drive-thru width	83" (7 feet) / 2,112 mm	90.75" (7.7 feet) / 2,305 mm
Control Stand – Rear of the Lift		
A Total width	103" (8.6 feet) / 2,616 mm	111" (9.3 feet) / 2,815 mm
A1 Total width (with Window in Bottom Connector Tube)*	106" (9 feet) / 2,695 mm	114" (9.6 feet) / 2,898 mm
B Platform width	83.75" (7 feet) / 2,127 mm	91.75" (7.7 feet) / 2,331 mm
C Drive-thru width	83" (7 feet) / 2,112 mm	90.75" (7.7 feet) / 2,305 mm
Rise/Lower speed	30 seconds	
Motor	220 VAC at 60 Hz, 5 HP, 1 Ph 208-230/460 VAC at 50/60 Hz, 10 HP, 3 Ph	

*For installations placing the Control Stand at the **Rear** of the Lift, use total width measurement (**A**) for creating Chalk Line Guides; do not use the A1 measurement.

Positioning the Bottom Connector Tube

If you want to position the Control Stand at the **Rear** end of Lift (the Drive-up end), make sure the Window for routing the Control Stand wires through the Bottom Connector Tube is on the same side of the Lift where the Control Stand will go.

If you want to place the Control Stand at the **Front** of the Lift, continue to the next section.

The Window for the Control Stand wiring can go on either side of the Lift, as long as the small gap on the Bottom Connector Tube (from the top Bolts to the top of the Tube) remains at the top and the large gap (from the bottom Bolts to the bottom of the Tube) is at the bottom, as shown below.

The Power Unit must also be near the Front of the first Lift (the Lift closest to the Power Unit); it can go on either side of your setup, up to 30 inches away.

The following drawing shows the general arrangement for the Bottom Connector Tube.

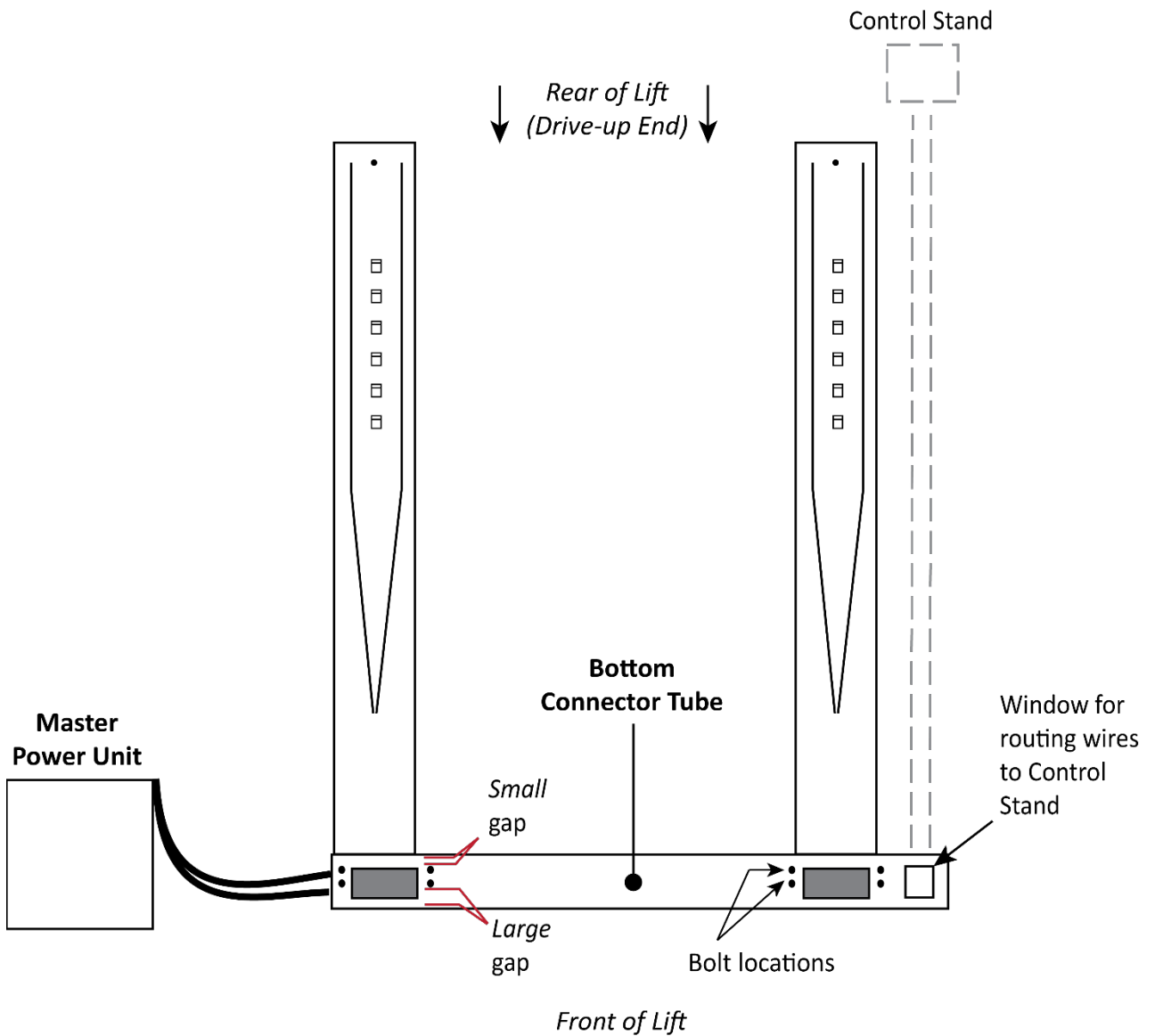

Installing the Hydraulic Hoses

To install the Hydraulic Hoses, you will use parts from two separate kits: The MPU Plumbing Kit and the Control Kit.

To connect the Power Unit to the first Lift, you will need from the **MPU Plumbing Kit**:

- **1 Medium Hydraulic Hose**
- **1 Extra-Long Hydraulic Hose**
- **2 Steel Hydraulic Lines**
- **2 JIC x JIC Nipple Fittings**
- **2 JIC x ORB Elbow Fittings**
- **2 JIC Cap Fittings**

In addition, for **each** Lift in your setup, you will need from the **Control Kit**:

- **2 Solenoid Valve Blocks**
- **2 Short Hydraulic Hoses**
- **2 Long Hydraulic Hoses**
- **2 JIC x ORB Elbow Fittings**
- **2 ORB x NPT Fittings**

The following drawing shows the major connections to make to your Hydraulic System.

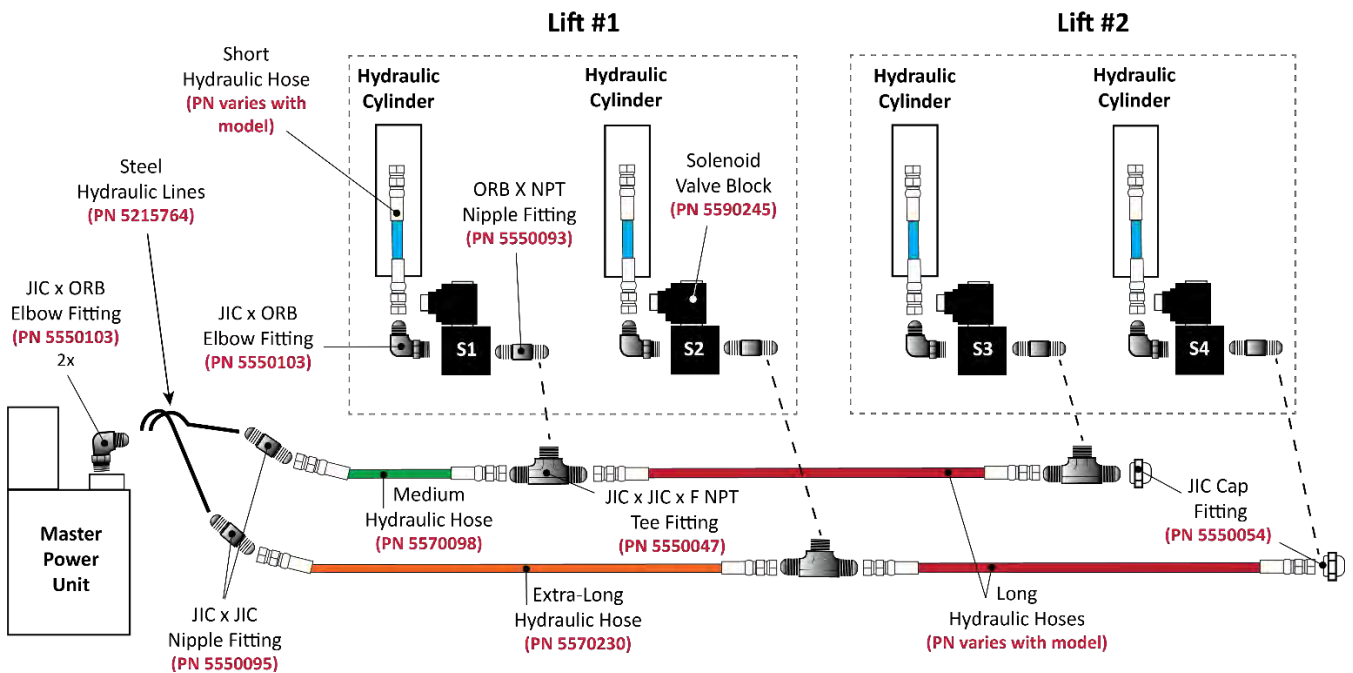

Front/Side view. Not to scale. Not all components show; some exaggerated for easier understanding. Hydraulic Hoses are routed through the Bottom Connector Tube.

To install the Hydraulic Hoses:

1. Install a Velocity Fuse in the connectors near the bottom of each Hydraulic Cylinder; finger tighten those connections, as shown in the graphic on the following page.
To learn about Velocity Fuses, refer to [About Velocity Fuses](#) for more information.
2. On each Cylinder, remove one Nut from the Bulkhead Fitting, put the Bulkhead Fitting into the Connector Weldment, put the Nut you just removed back onto the Bulkhead Fitting, and finger tighten both Nuts around the Connector Weldment.
3. On each Cylinder, connect the Hydraulic Line Assembly to the top end of the Bulkhead Fitting and the other end to the top end of the Velocity Fuse; finger tighten all the connections.

The following drawing shows a close-up of the connections to make to the Hydraulic Cylinders.

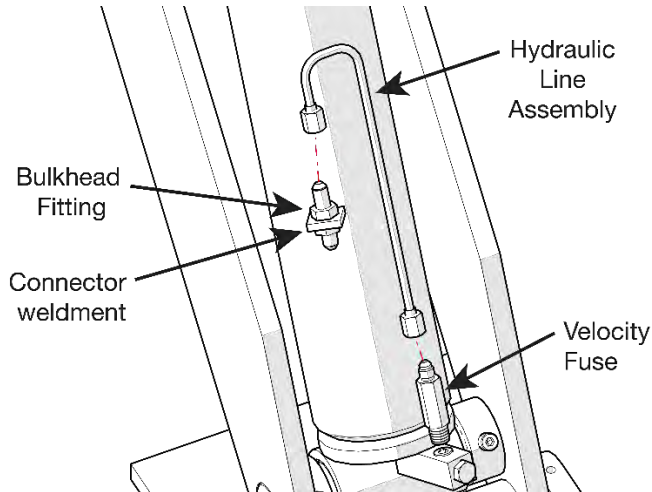

View is a close-up of the Hydraulic Cylinders on the Lift.

Not all components are shown.

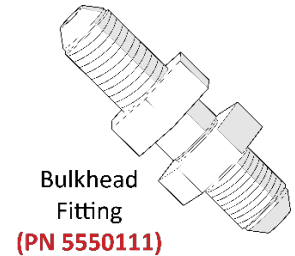

4. Find the necessary components for preparing the Solenoid Valve Blocks.
5. Prepare two Solenoid Blocks, with an Elbow Fitting and a Nipple Fitting in their required locations.

Use Thread Sealant on NPT Threads only.

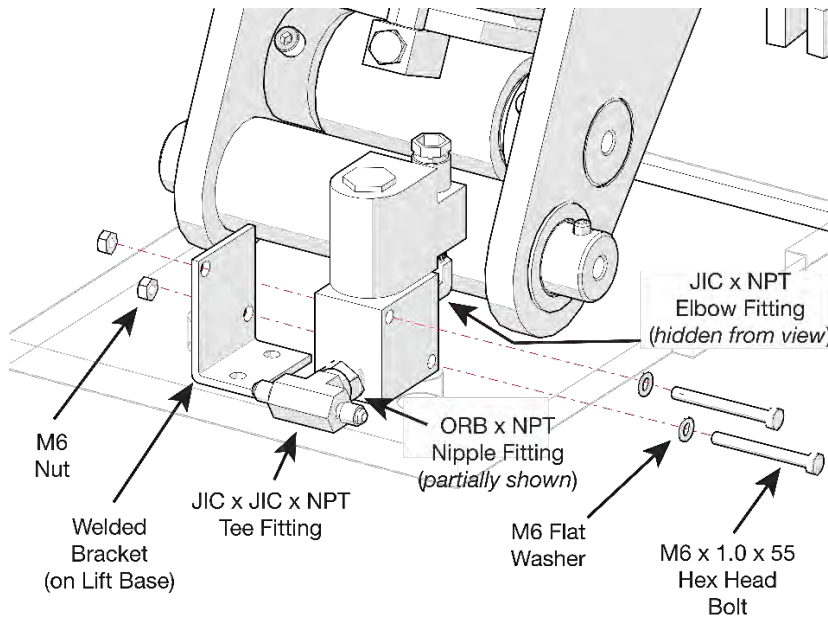

Drawing shows a close-up of the Solenoid connections.

Not all components are shown.

6. Attach the NPT end of the Tee Fitting to each Straight Fitting, then secure the Solenoid Blocks to the Lift Bases using two M6 x 1.0 x 55 Bolts, M6 Nuts and M6 Flat Washers per each Block.

Use Thread Sealant on NPT Threads only.

7. Attach a Short Hydraulic Hose to each Hydraulic Line Assembly, then attach the other end of each Hose to the Elbow Fitting on the Solenoid Blocks.

The Solenoid Valve Blocks are **not** labeled S1 through S4; they are only labeled in this section to distinguish between the various components.



Tip Reference the illustration on Page 51 for the overall Hydraulic Hose routing.

8. Remove the Power Unit from its packaging, then place the Power Unit near the first Lift.
9. Attach an Elbow Fitting from the MPU Plumbing Kit to each Hydraulic Out Port on the Power Unit.

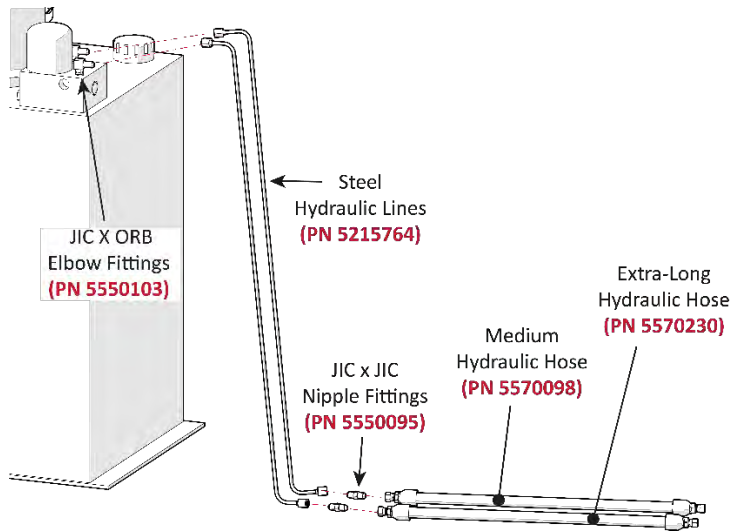

Drawing shows the Hydraulic connections to make to the Master Power Unit.

Not all components are shown.

10. Connect the two Steel Hydraulic Lines from the MPU Plumbing Kit to the Hydraulic Elbow Fittings you just connected to the Power Unit.
11. Find the Medium and Extra-Long Hydraulic Hose from the MPU Plumbing Kit and connect them to the Steel Hydraulic Lines using two Nipple Fittings.
12. Connect the other end of the Medium Hydraulic Hose to the Tee Fitting attached to S1.
13. Connect the other end of the Extra-Long Hydraulic Hose to the Tee Fitting attached to S2.
14. Take the Long Hydraulic Hose and connect it to the unattached end of the Tee Fitting on S1.
15. Using the components from the Control Kit for the next Lift, prepare the next set of Hydraulic Cylinders. Refer to Steps 1 through 8 for additional instruction.
16. Using the same Long Hydraulic Hose attached to S1 on the first Lift, connect the other end to the Tee Fitting on S3 on the next Lift.
17. Connect the second Long Hydraulic Hose to the Tee Fitting on S2 on the first Lift, then connect the other end of the same Hose to the Tee Fitting connected to S4 on the next Lift.
18. If there are no further Lifts to connect to, secure the unattached ends of the Tee Fittings with a Cap Fitting, as shown in the following drawing.

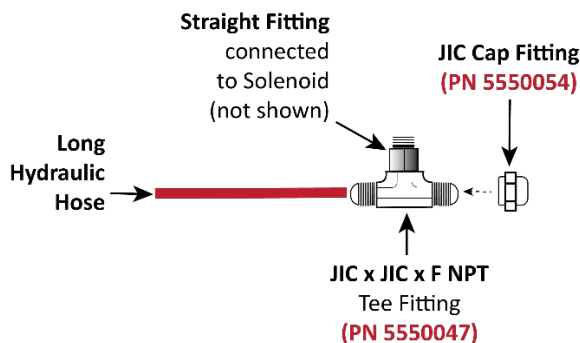

Drawing shows the connections to make to the last set of Long Hydraulic Hoses.

Not all components shown. Not drawn to scale.

NOTICE If there are additional Lifts to connect the Hydraulic Hoses to, continue repeating Steps 1 through 17 until you reach your desired configuration, and then complete Step 18.

Installing the Return Line

As previously mentioned, the Return Line takes extra Hydraulic Fluid from the Hydraulic Cylinders and returns it to the Power Unit's Reservoir; refer to [Connect the Return Lines](#) for more information.

Use Thread Sealant with NPT Threads only.

The following drawing shows how to connect the Return Lines between two Autostackers.

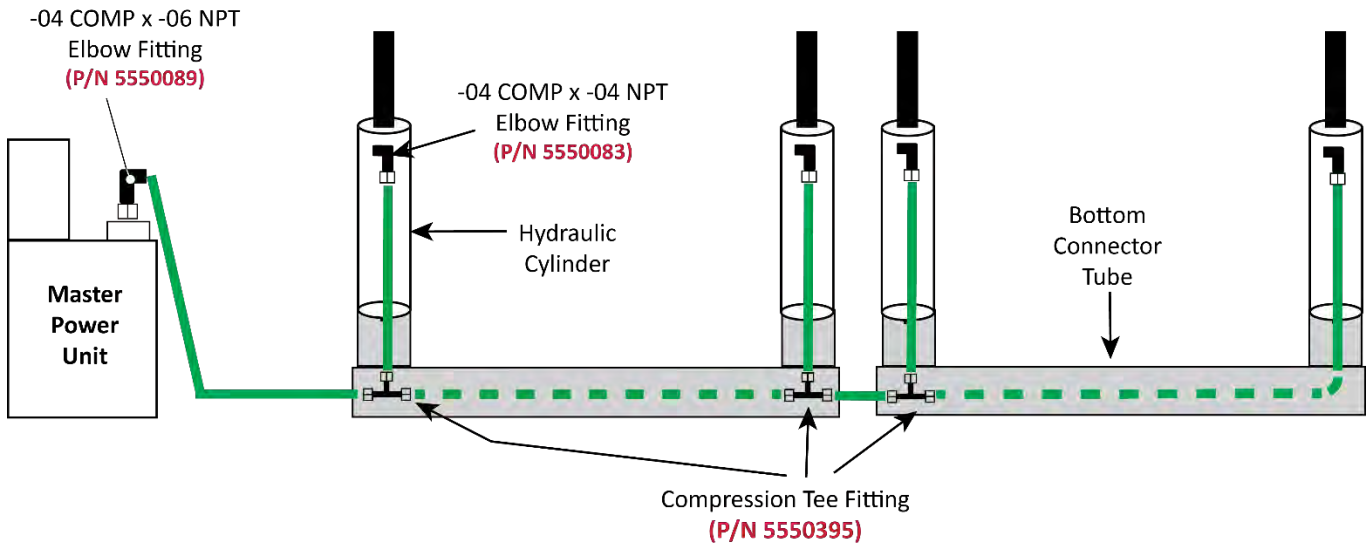

*Front/Side view. Not to scale. Some components not shown or exaggerated for easier understanding. The Return Line is routed **through** the Bottom Connector Tube.*

To install the Return Line:

1. Attach an Elbow Fitting to the Hydraulic Return Port on the Power Unit.

⚠ CAUTION The Hydraulic Return Ports are commonly labeled **T1/T2**, **CV1/CV2**, or **G**; the Hydraulic Pressure Ports are almost always labeled **P1/P2**. Do not accidentally attach a Hydraulic Hose to the Return Line Port or vice versa. Your Autostacker will **not** work right unless the Return Line and Hydraulic Hoses are attached to the correct Ports.

2. Attach an Elbow Fitting near the top of each Hydraulic Cylinder.
3. Attach a Tee Fitting near the bottom of each Cylinder.

The Hydraulic Cylinder furthest from the Power Unit (on the last Lift in your Multi-Lift configuration) does not need a Tee Fitting, as shown in the drawing.

4. Find the Return Line Tubing and measure the lengths of the segments you need, then cut the appropriate lengths.
5. Connect the various pieces of Tubing to the Elbow Fittings and Tee Fittings on each Lift in your setup, as shown in the drawing above.

See [Working with Return Lines and Compression Fittings](#) for more information.

6. If there are no further Lifts to connect to, connect a final Return Line to the top of the last Hydraulic Cylinder, and the other end to the Tee Fitting on the first Hydraulic Cylinder (on the same Lift).

Make sure the final segment is long enough to reach from the Tee Fitting, through the Bottom Connector Tube, and to the top of the last Hydraulic Cylinder.

Attach the Conduit Tube

In order to place the Control Stand at the **Rear** of the Lift, you need to first attach the Conduit Tube to the Bottom Connector Tube; the Conduit Tubes protects the Control Stand wiring from being exposed and damaged.

If you plan to position the Control Stand at the **Front** of the Lift, continue to the next section.

The components involved include:

- **Conduit Cover Plates.** Attach to the Windows on either side of the Bottom Connector Tube.
- **Conduit Fitting.** Attaches to the Conduit Cover Plate and holds one side of the Conduit Tube.
- **Conduit Tube.** Attaches to the Conduit Fitting. Used for routing the Control Stand wiring.

The following drawing shows how to attach the Conduit Tube to the Bottom Connector Tube.

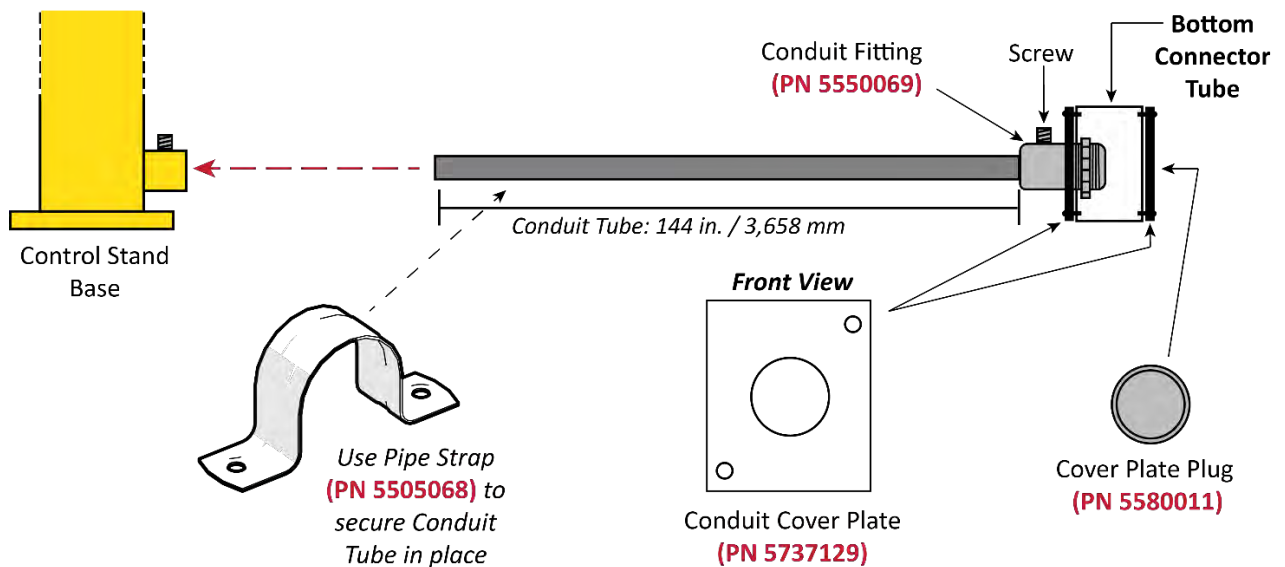

Side view. Not to scale. Not all components are shown.

Note: Depending on your layout, you can trim the Conduit Tube to fit different Control Stand locations; some customers prefer to have the Control Stand closer to the Lift for easier Vehicle drive-on and drive-off. For safety purposes, the Control Stand must be kept within a safe distance from the Lift and **the Control Stand operator must always have a clear, unobstructed view of the Lift.**

To attach the Conduit Tube:

1. Find the Conduit Cover Plates (2), Conduit Fitting, and Cover Plate Plug.
2. Attach the Conduit Fitting to the Conduit Cover Plate, then attach the Conduit Cover Plate to the Window on the Bottom Connector Tube; the other Cover Plate goes on the other side of the Bottom Connector Plate.

Use four M6 x 1 x 10 Screws.

For the Conduit Cover Plate facing the non-approach side of the Lift, insert the Cover Plate Plug in place.

3. Connect the Conduit Tube to the Conduit Fitting, then adjust the screw on the Fitting to hold the Tube securely in place.

Installing the Control Stands

The Control Stand holds the Controls to operate a Lift in your setup; each Lift has its **own** Control Stand. The Control Stand can be placed at the Front or Rear of the Lift, although the installation for either orientation is different. Those procedures are described here.

NOTICE The following steps explain how to **install**, but not make the connections to, the Controls for each Lift. An Electrician is **not** needed to install the Controls, only to connect them to the Power Unit.

⚠ DANGER Do not connect the wires to the Power Unit at this point; that task is for an Electrician. **All wiring connections to the Power Unit must be performed by a licensed, certified Electrician.**

Each Control Stand requires three Electrical Cables:

- **#14Awg – 6 wires**; one end of the Cable goes to the Power Unit, and the other end goes through the Bottom Connector Tube, interlinking all of the Lifts in your configuration.
- **#14Awg – 8 wires**; one end of the Cable connects the Controls on each Stand, the other end connects to the 14Awg-6 Cable in the Bottom Connector.
- **#16Awg – 2 wires**. Connects the two Solenoids on each Lift, and the other end goes to the Controls on the Control Stand.

The following graphic shows the various connections to make to the Control Stands.

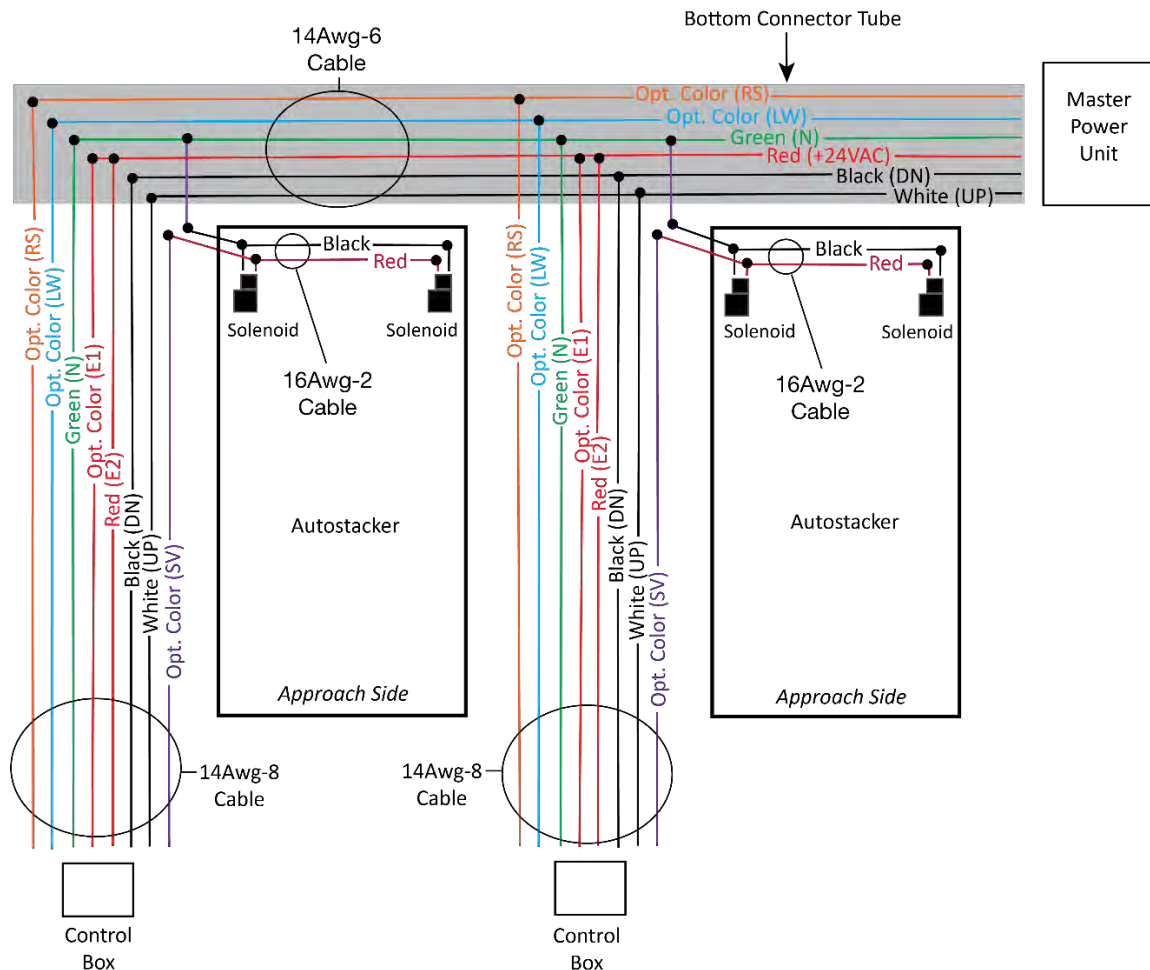

Not drawn to scale. Some components are missing or exaggerated for easier understanding.

The following drawing shows the Control Stand at the **Front** of the Lift.

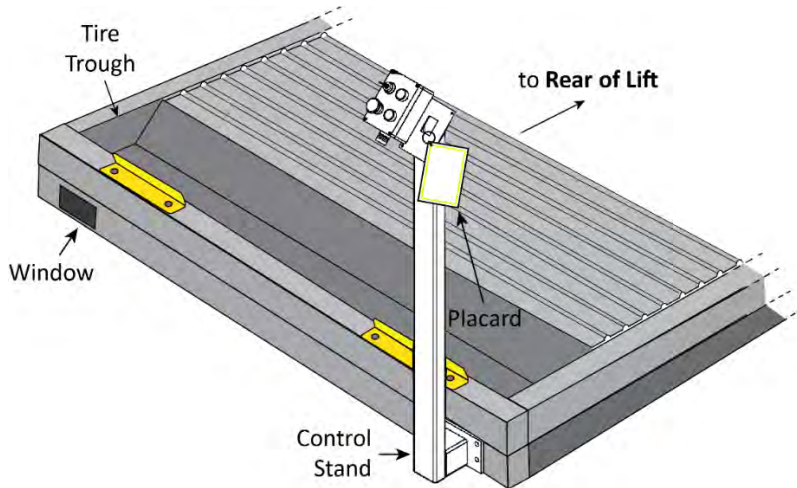

Drawing shows the Stand at the Front of the Lift.

Not necessarily to scale. Not all components shown.



Safety Placard

To install the Control Stand at the Front of the Lift:

1. Find the Control Box, Control Stand, and the 3 Electrical Cables from the Control Kit.
2. By the Power Unit, route the 14-6 Cable through the Bottom Connector Tube.
3. Place the Control Stand nearby the selected Window, with the opening at the bottom of the Control Stand facing towards the Lift.
4. Remove the Screws from the Control Box to have access to the wiring inside.
5. Connect the 14-8 Cable to the Controls, then route the Cables through the Stand.
6. Connect the 16-2 Cable to the two Solenoids on each Lift.
7. Connect the 14-8 to the 14-6 wiring (coming out of the Bottom Connector Tube) using Wire Nuts.
8. Attach the Control Box to the Stand, with the Safety Placard in place.

The following drawing shows the connections to make to the Control Stand.

Top of Control Stand

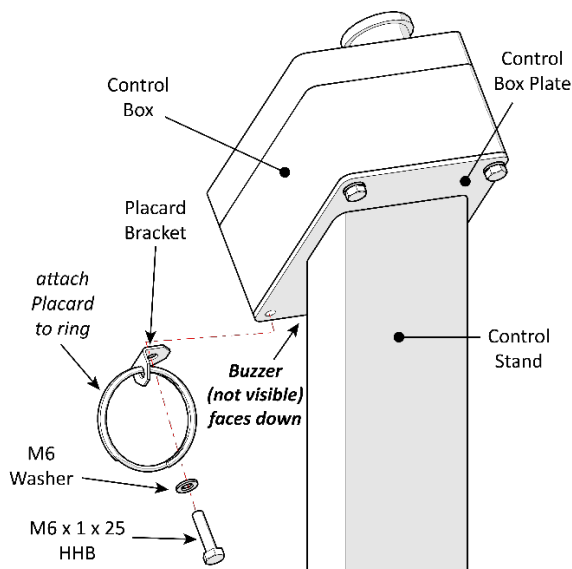

Bottom of Control Stand

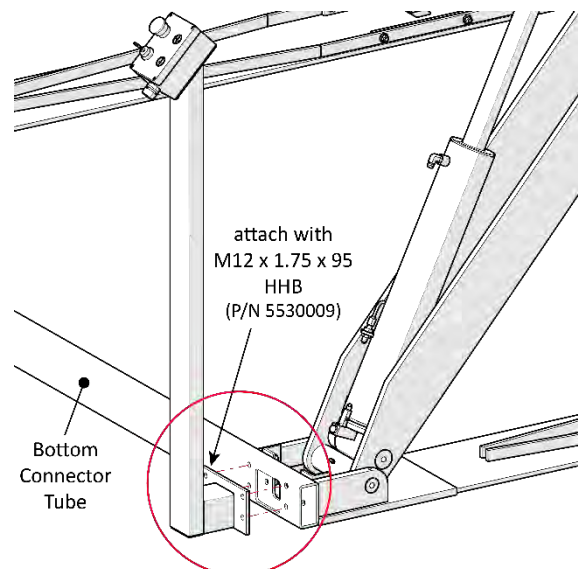

The following drawing shows the Control Stands at the **Rear** of the Lift.

Use the Cable routing diagram on Page 56 for a more detailed routing illustration.

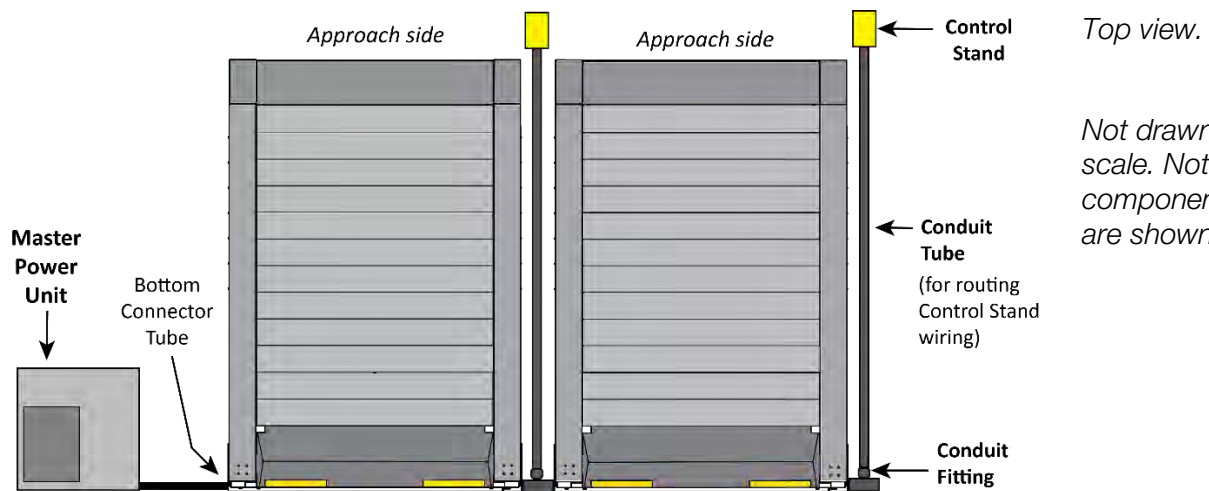

To install the Control Stand at the **Rear** of the Lift:

1. Find the 14-6 Cable and route it through the Bottom Connector Tube to the Conduit Fitting.
2. Use the 16-2 Cable to connect the Solenoids near the bottom of each Cylinder (two per Lift).
3. Route the 14-8 and 16-2 Cables all the way through the Conduit Tube, then attach the Cables to the 14-6 wiring (coming out of the Bottom Connector Tube).
4. Remove the Cover of the Control Box to have access to the wiring inside.
5. Find the Control Stand, then route the other end of the 14-8 and 16-2 (that was routed through the Conduit Tube) through the opening in the Control Stand.
6. Connect the wires to the Controls inside the Control Box.
7. Once the wiring is routed through the Conduit Tube and connected to the Control Box, connect the Conduit Tube to the Control Stand.
8. Attach the Control Box to the Control Stand, as described in the previous procedure.
9. When you are ready to anchor the Control Stand, use the two holes on the Control Stand Base to mark the locations on the ground.
10. Move the Control Stand out of the way, then drill two holes 3/8" diameter by 4" (102 mm) deep in the concrete floor at the locations you marked.
Go in straight; do not let the drill wobble. Use a carbide bit (conforming to the current ANSI B212.15).
11. Remove all dust from the holes.
12. Use a wire brush, vacuum, hand pump, or compressed air. Do **not** ream the hole. Do **not** make the hole any wider than the drill made it.
13. Move the Control Stand in place over the two holes, then insert an Anchor Bolt with a Washer into each hole, tapping it down into the hole.
14. Wrench the Anchor Bolt clockwise to the recommended installation torque, 25-30 pound feet, using a Torque Wrench.

Contacting the Electrician

As mentioned previously, there are installation tasks that **require** a licensed, certified Electrician.

⚠ DANGER All wiring **must** be performed by a licensed, certified Electrician. If someone who is not a certified Electrician attempts these tasks, they could damage the Lift or be electrocuted, resulting in serious injury or even death.

The Electrician needs to:

- **Connect a power source to the Master Power Unit.** A power source is required. The Power Unit comes with a pigtail for wiring to a power source. Have your Electrician connect a power cord with plug on the electrical box on the Lift (for connection to a power outlet) or have them wire it directly into the electrical system at the Lift location.
- **Connect the Control Stands to the MPU.** A power source is required.
- **Install a Power Disconnect Switch.** Ensures you can quickly and completely interrupt electrical power to the Lift in the event of an electrical circuit fault, emergency situation, or when equipment is undergoing service or maintenance.
- **Install a Thermal Disconnect Switch.** Ensures the equipment shuts down in the event of an overload or an overheated motor.

The Electrician is responsible for providing:

- an appropriate plug to attach to the Power Unit
- an appropriate Power Cord that goes from the power source to the plug on the Power Unit

Important electrical information:

- 220 VAC, 60 Hz, single phase, 5 HP requires a minimum 8 AWG wire
- 208-230 VAC, 50/60 Hz, three phase, 10 HP requires a minimum 8 AWG wire
- 460 VAC, 60 Hz, three phase, 10 HP requires a minimum 10 AWG wire

⚠ DANGER Risk of explosion: This equipment has internal arcing or parts that may spark and should not be exposed to flammable vapors. The Power Unit's motor should not be located in a recessed area or below floor level. Never expose the motor to rain or other damp environments; damage to the motor caused by water is **not** covered by the warranty.

Connecting the Master Power Unit

The Power Unit for your Lift setup is either 220 VAC, 60Hz, 1Ph or 208-230/460 VAC, 50/60 Hz, 3 Ph. The Power Unit must be connected to an appropriate power source.

BendPak offers an optional MPU Enclosure that protects the Power Unit from the outdoor elements. Call **(800) 253-2363** for more information.

⚠ DANGER All wiring **must** be performed only by a licensed, certified Electrician.

Refer to **Wiring Diagrams** for wiring information.

The Master Power Unit has multiple connections:

- **Two Steel Hydraulic Lines and One Return Line.** Already in place and connected.
- **Control Stand Cable.** Connects the Control Stands to the power source.
- **Power Cable.** Connects the Power Unit to the power source.
- **Power Source.** A power source is needed to operate the Lifts.

⚠ CAUTION The Hydraulic Power Ports are almost always labeled **P1/P2**; the Hydraulic Return Ports are commonly labeled **T1/T2, CV1/CV2, or G**. Do not accidentally attach a Hydraulic Hose to the Return Line Port. Your Autostacker will not work right unless the Hydraulic Hoses and the Return Line are attached to the correct connector.

The following drawing shows the connections to make to your Master Power Unit.

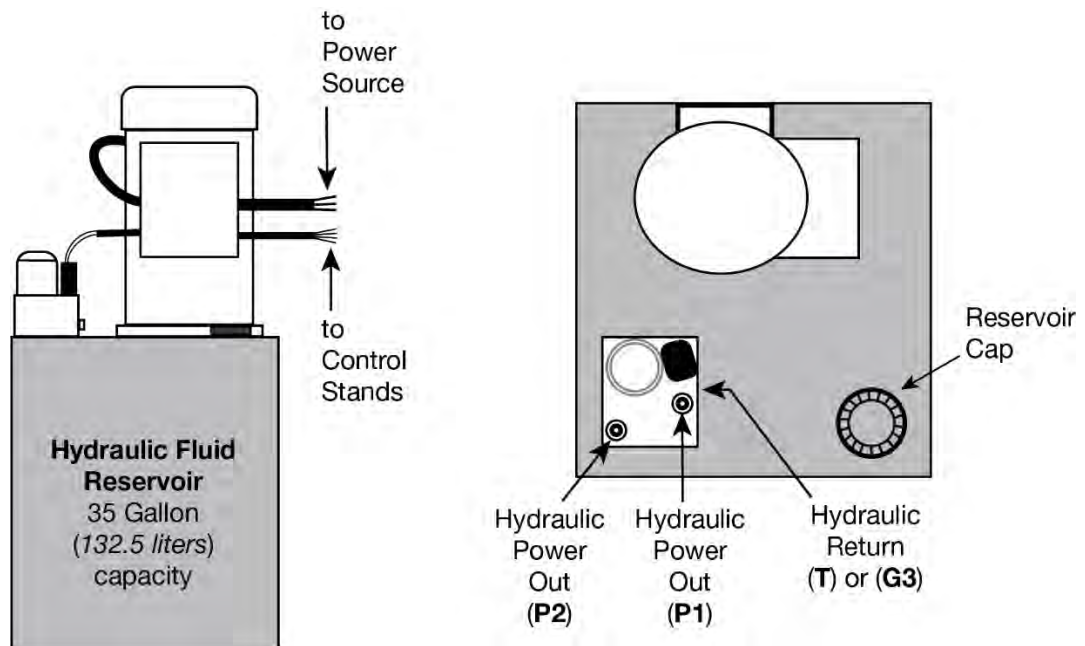

Drawing not to scale. Not all components shown. Drawing shows top view and side view of the same area. The Hydraulic Return Port is on the side of the Valve Block.

⚠ DANGER All wiring **must** be performed only by a licensed, certified Electrician. Do not perform any maintenance or installation on the Lift without first making sure that main electrical power has been disconnected from the Lift and cannot be re-energized until all procedures are complete. If your organization has Lockout/Tagout policies, implement them after connecting to a power source.

To connect to a power source:

1. Have a certified, licensed Electrician connect an appropriate plug to the wiring, coming out of the Power Unit.

The plug is *not* supplied with the Power Unit.

2. Connect the power source cable to the plug you just connected.

The power source cable is *not* supplied with the Power Unit.

Refer to **Wiring Diagrams** for wiring information.

3. Connect the Control Stands to the Power Unit.

Refer to **Wiring Diagrams** for wiring information.

4. Connect the Power Disconnect Switch and Thermal Disconnect Switch.

Refer to **Wiring Diagrams** for wiring information.

5. Have a certified, licensed Electrician check for any loose connections.

6. Fill the Hydraulic Fluid Reservoir.

The Power Unit's Hydraulic Fluid reservoir must be filled with Hydraulic Fluid or Automatic Transmission Fluid before you begin operation. When you receive it, the reservoir is empty; the Power Unit will not work correctly until there is an adequate supply of the approved fluids.

Approved fluids are any general purpose ISO-32, ISO-46, or ISO-68 hydraulic oil or approved automatic transmission fluids such as Dexron III, Dexron VI, Mercon V, Mercon LV, or any synthetic multi-vehicle automatic transmission fluid.

⚠ WARNING Do not run the Power Unit without Hydraulic Fluid; you will damage it. Keep the Power Unit dry; damage to the Power Unit caused by water, detergents, acids, and other liquids is not covered by the warranty.

Operation

Before operating an Autostacker in your Multi-Autostacker lineup, make sure to check the Lift and the surrounding area for safety. Refer to **Preparing to Raise or Lower a Vehicle** for a safety checklist and operation instructions.

The Controls

Your Autostacker is operated via the Controls; the Controls used in your Multi-Lift setup are similar to the Controls used with a standard Autostacker. Refer to **The Autostacker Console** for more information.

⚠ WARNING Only one Autostacker can be raised or lowered at a time. Do not attempt to operate more than one Lift at the same time; you will damage the Power Unit.

The following graphics show the Controls for a standard Autostacker and the Controls for each Lift in a Multi-Lift configuration.

The Controls for a *single* Autostacker:



The Controls for *multiple* Autostackers (one per Lift):



Multi-Autostacker Maintenance

In addition to the steps outlined in the maintenance section for a single-Lift configuration, there are a few extra things to look for:

- **Daily.** Make sure the electrical connections are covered and protected from all sources of moisture.
- **Monthly.** Make sure the Master Power Unit and Reservoir are contaminant-free; if there is debris in the system, the Lift(s) may not work correctly. Use air or a wire brush to remove debris from the Power Unit components (for example: the Lowering Valve, which is a component inside the Master Power Unit).
- **Monthly.** Raise each Lift to the top Safety Lock and then lower back to the ground, to make sure the Lifts are working normally.
- **Every two months.** Check the Control Stand Bolts to make sure they are tight; secure any loose Bolts.
- **Yearly.** Have a licensed, certified Electrician come to your site to check all electrical connections.

⚠ DANGER Before performing **any** maintenance on your Autostacker, make sure it is **completely disconnected from power**. If your organization uses Lockout/Tagout policies, make sure to implement them after connecting to a power source.

For more information about maintaining your Autostacker, see **Maintenance** and **Outdoor Usage**.

Optional MPU Enclosure

The optional MPU Enclosure (PN 5215860) protects the Power Unit from the outdoor elements.



Tip

We recommend that you first situate the Master Power Unit inside the Base, then assemble the Enclosure around it.



CAUTION

The Master Power Unit is heavy; use caution when moving it. You must use a Forklift, Shop Crane, or other lifting device when moving it to its location.

The following drawing shows the components that make up the MPU Enclosure.

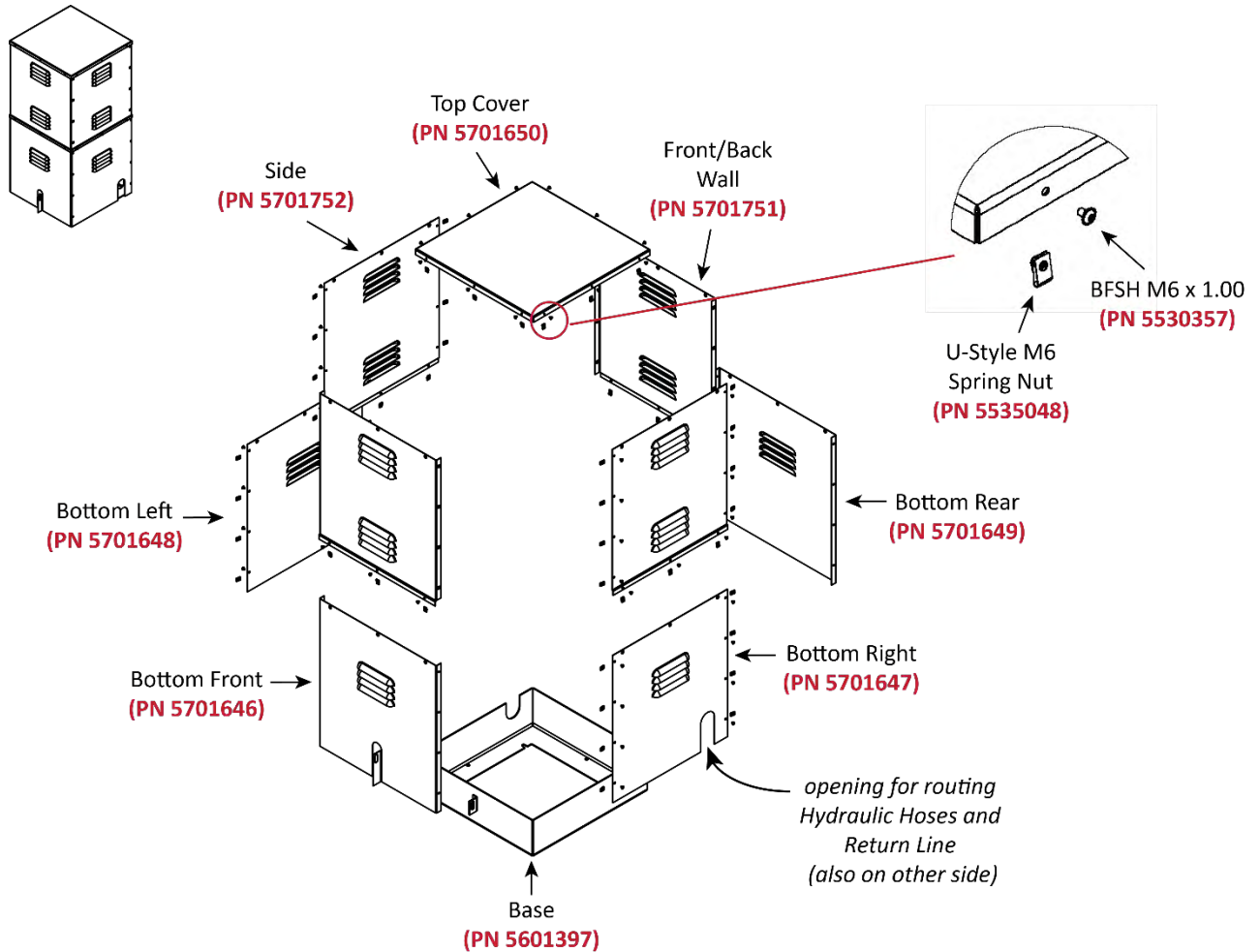

To assemble the MPU Enclosure:

1. Locate the 56 Spring Nuts and Socket Head Cap Screws.
2. Assemble the components near where you are going to install it.

Note: Some components look the same, but are *not* interchangeable.

3. Place the Top Section above the Base Section.

Wiring Diagrams

110V Power Unit, 1Ph:

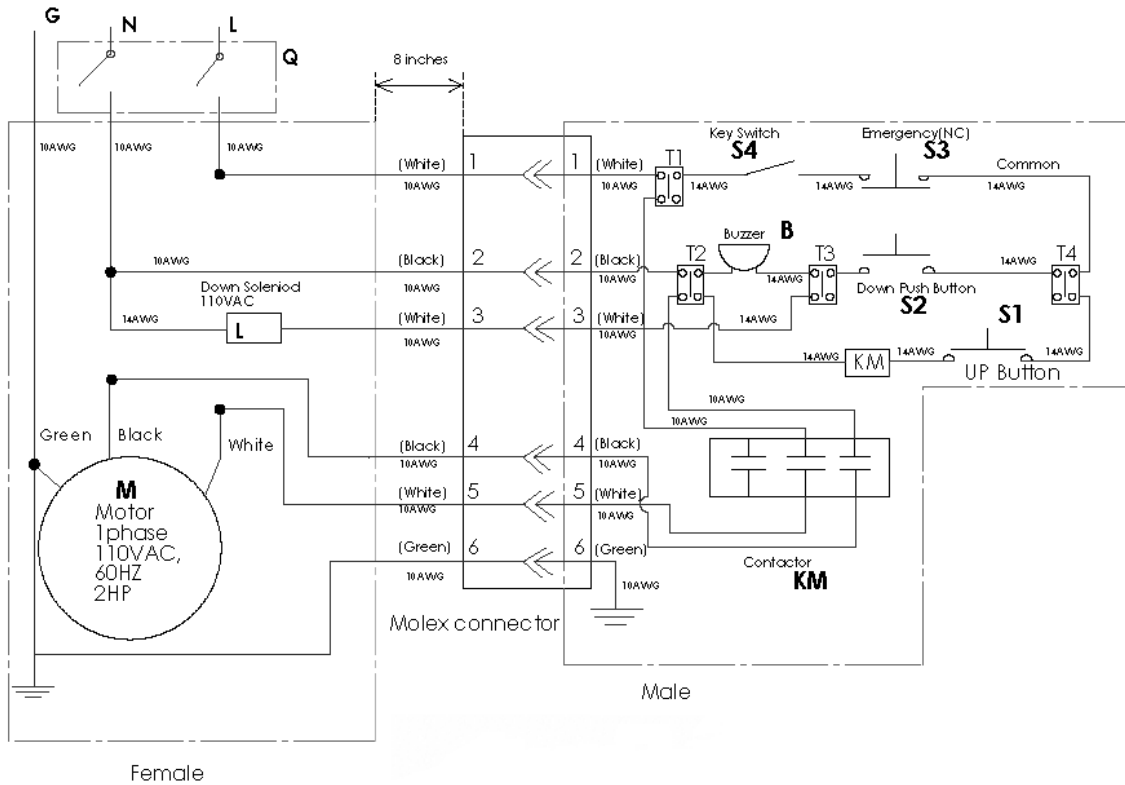

220V Power Unit, 1Ph:

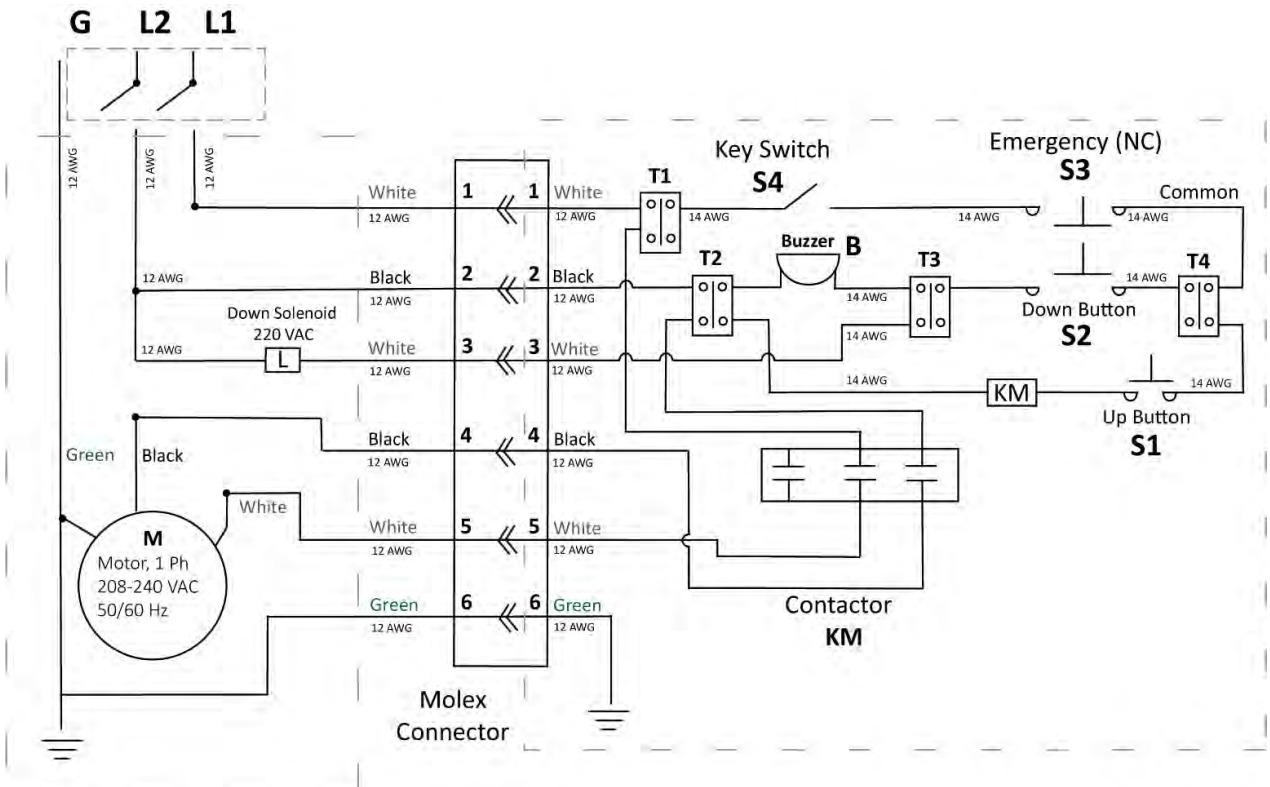

Select voltage, 3Ph:

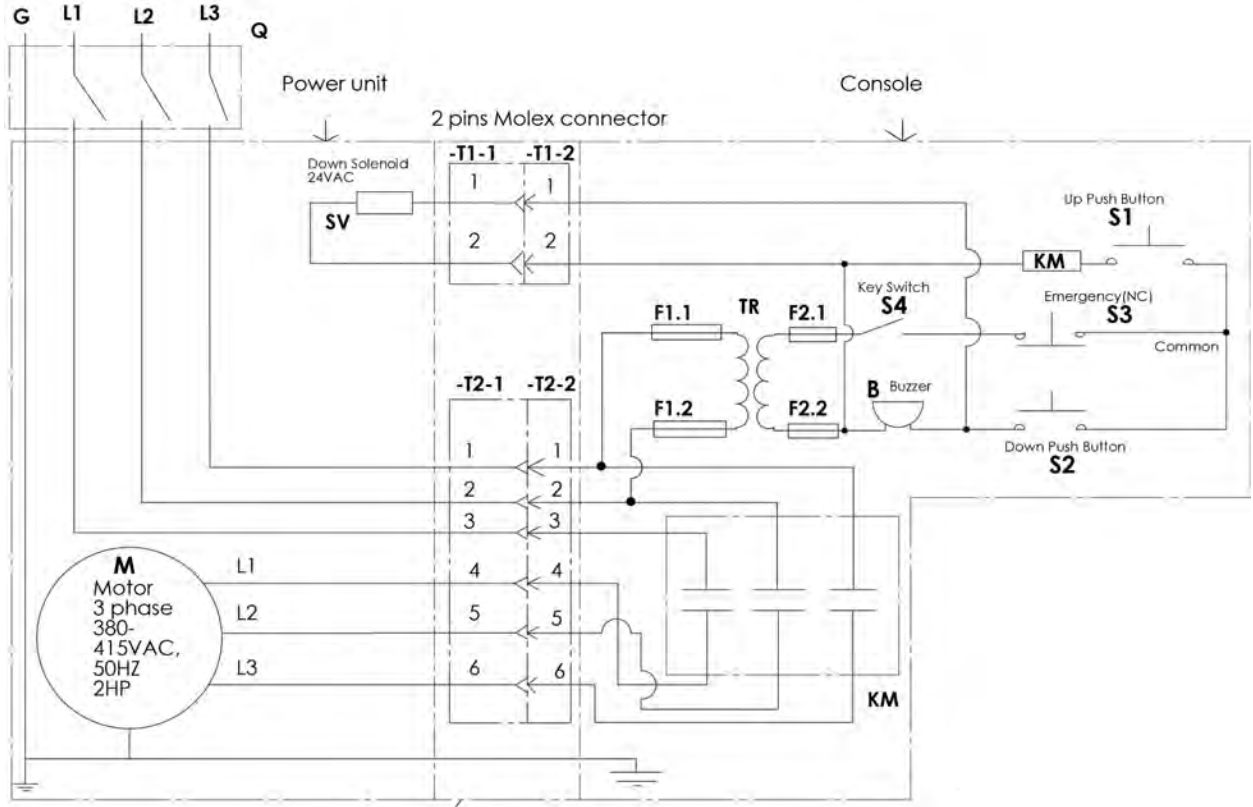

Multi-Autostacker

Control Stand:

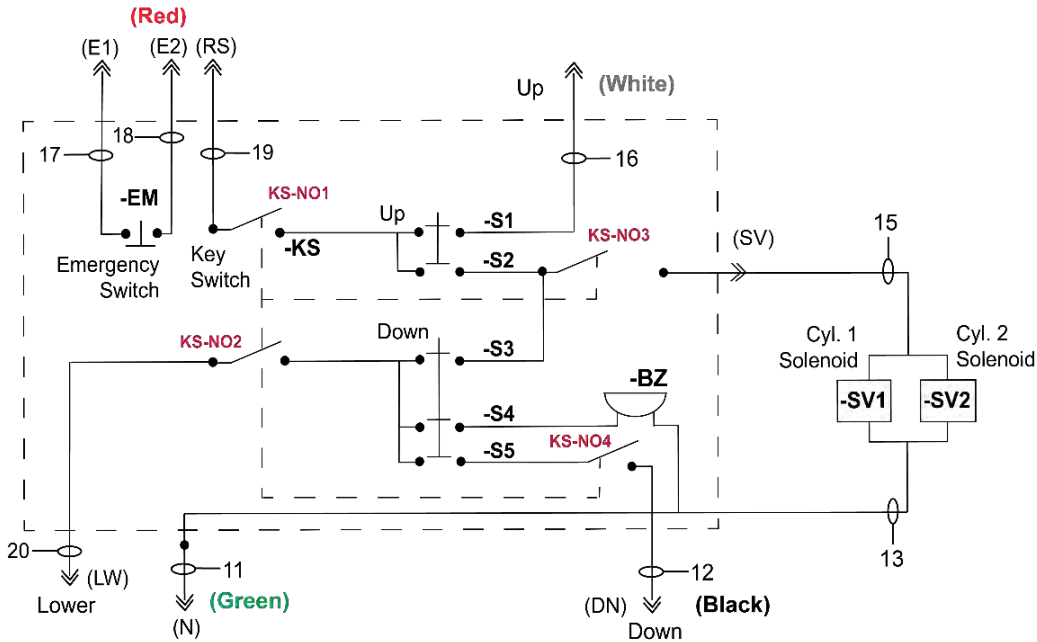

Master Power Unit, 1Ph:

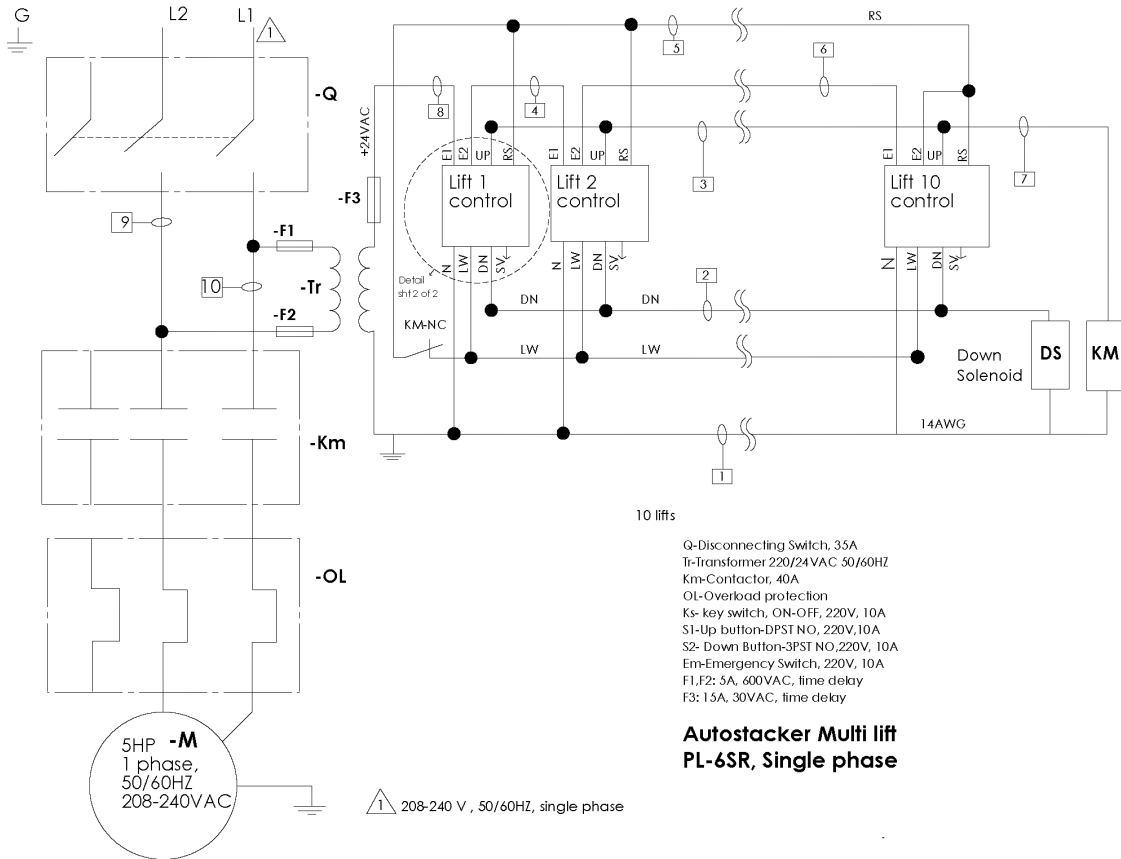

Master Power Unit, 3Ph:

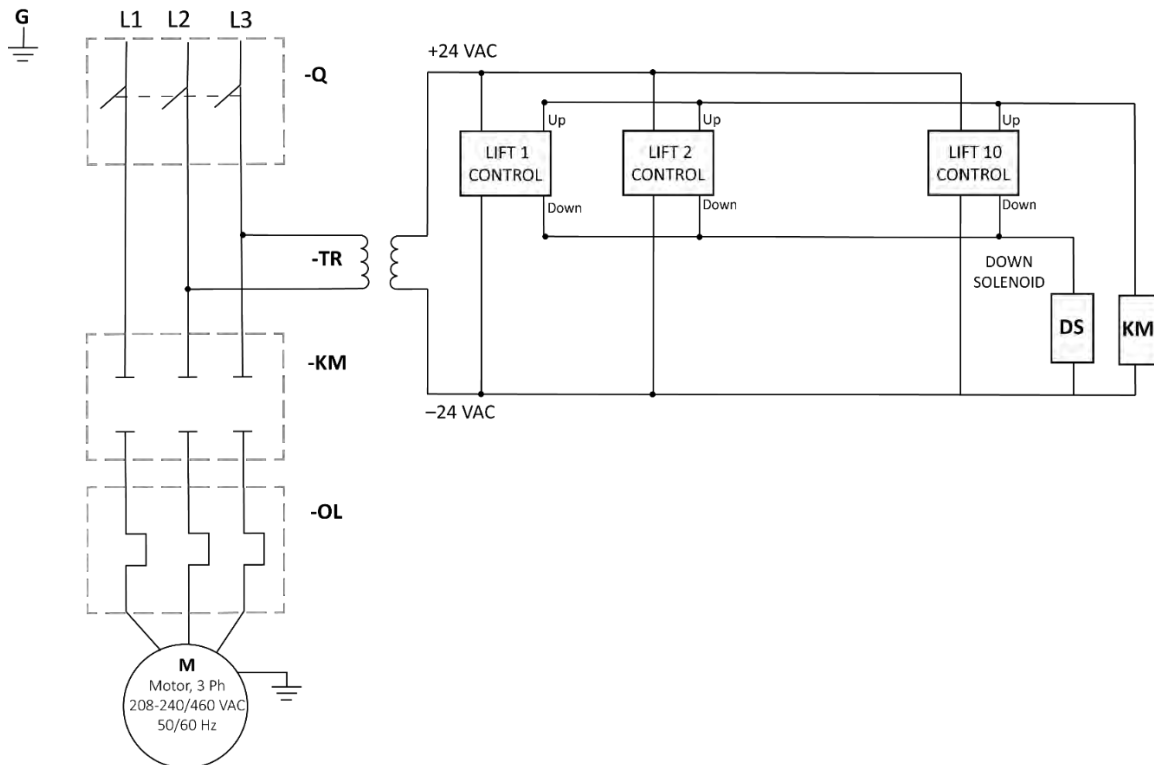

Labels

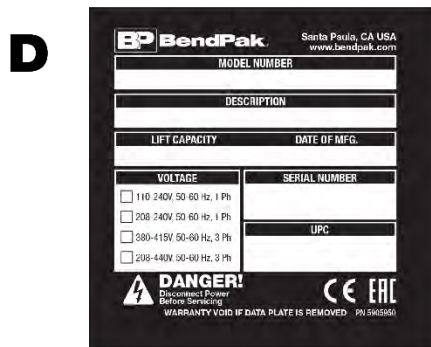

I
(or **L**
for OPT
1)



J
(or **I** for
OPT 1)

WARNING - STAY CLEAR

PRE-LIFT OPERATION

1. Read the operator's manual for this lift before operating it. Do not operate it until you are fully trained and authorized to do so.
2. Inspect the lift before operating it. Do not operate it if you find any damage or if it is not in good working order.
3. Do not operate the lift if you are under the influence of alcohol, drugs, or medication that could impair your ability to operate the lift safely.
4. Do not operate the lift if you are wearing any loose clothing or jewelry that could become entangled in the lift's moving parts.
5. Do not operate the lift if you are wearing any shoes that do not have proper tread or are not laced properly.
6. Do not operate the lift if you are wearing any safety glasses that are not properly secured.
7. Do not operate the lift if you are wearing any hard hat that is not properly secured.
8. Do not operate the lift if you are wearing any fall protection that is not properly secured.
9. Do not operate the lift if you are wearing any safety harness that is not properly secured.
10. Do not operate the lift if you are wearing any safety net that is not properly secured.

IMPORTANT NOTE

Never allow anyone to stand on the lift platform while it is in motion. Do not allow anyone to stand on the lift platform while it is being lowered. Do not allow anyone to stand on the lift platform while it is being raised. Do not allow anyone to stand on the lift platform while it is being lowered. Do not allow anyone to stand on the lift platform while it is being raised.

EMERGENCY STOP

OFF ON

STOP

SAFETY FIRST

Autostacker

UP DOWN

J
(OPT 1
Only)

M

WARNING

Electrical Shock Hazard. DO NOT remove cover. Refer servicing to qualified service personnel.

WARNING Read all the instructions before operating this equipment.

CAUTION For installation in non-hazardous locations only.

N

CAUTION

For continued protection against risk of fire, replace **ONLY** with a fuse of the same type and having the same electrical rating.

O

WARNING

Always make sure safeties are in **locked** position before approaching a raised platform.

SAFETY IN LOCKED POSITION

SAFETY NOT LOCKED

SAFETY NOT LOCKED

K

PRE-LIFT OPERATION

1. Read the operator's manual for this lift before operating it. Do not operate it until you are fully trained and authorized to do so.
2. Inspect the lift before operating it. Do not operate it if you find any damage or if it is not in good working order.
3. Do not operate the lift if you are under the influence of alcohol, drugs, or medication that could impair your ability to operate the lift safely.
4. Do not operate the lift if you are wearing any loose clothing or jewelry that could become entangled in the lift's moving parts.
5. Do not operate the lift if you are wearing any shoes that do not have proper tread or are not laced properly.
6. Do not operate the lift if you are wearing any safety glasses that are not properly secured.
7. Do not operate the lift if you are wearing any hard hat that is not properly secured.
8. Do not operate the lift if you are wearing any fall protection that is not properly secured.
9. Do not operate the lift if you are wearing any safety harness that is not properly secured.
10. Do not operate the lift if you are wearing any safety net that is not properly secured.

IMPORTANT NOTE

Never allow anyone to stand on the lift platform while it is in motion. Do not allow anyone to stand on the lift platform while it is being lowered. Do not allow anyone to stand on the lift platform while it is being raised. Do not allow anyone to stand on the lift platform while it is being lowered. Do not allow anyone to stand on the lift platform while it is being raised.

EMERGENCY STOP WARNING

Flow, when the Autostacker is in motion, is controlled by the lift's hydraulic system. If the lift is lowered, the flow will be stopped. If the lift is raised, the flow will be stopped. If the lift is lowered, the flow will be stopped. If the lift is raised, the flow will be stopped.

NEVER OPERATE MORE THAN ONE LIFT AT THE SAME TIME WHEN MULTIPLE LIFTS ARE CONNECTED TO A SINGLE POWER UNIT.

SAFETY IN LOCKED POSITION

SAFETY NOT LOCKED

L
(or **K** for
OPT 1)

WARNING - PLEASE READ

- Read the owner's manual in its entirety before operating this parking lift.
- **ALWAYS** use caution when operating this lift.
- **ALWAYS** ensure adequate clearance **BEFORE** driving vehicle onto lift platform.
- **NEVER** place any object or any part of your body on or near any part of the lift during operation. Serious injury or death can occur.
- Never allow children or persons under the influence of drugs or alcohol to use the lift.
- Serious injury, property damage, and/or death can occur if this lift is improperly used.
- Keep hands and feet clear from all moving parts. Keep clear of lift when lowering.

MONTHLY INSPECTIONS

An inspection should be performed on a monthly basis. Only trained personnel should perform inspections. Every monthly inspection should include but not be limited to the following:

- Check all items from floor-mounted safety lock components.
- Check all cables and their function for proper operation.
- Check all emergency stop safety devices.
- Inspect condition of all moving parts.
- Check for loose/missing parts.
- Inspect hydraulic system for leaks.
- Conduct visual inspection of shaft and components and/or other critical components, such as fasteners, pins, shaft, and using proper tools.
- Check for any abnormal noise or vibrations.
- Verify proper placement of all warnings and control markings.
- Ensure owner's manual is kept in a clean, dry place.
- Check additional items as listed in operation and service manuals.

WARNING - Any unit that is damaged or not operating properly must be immediately tagged and removed from service until proper repairs are completed. **ALWAYS** keep hydraulic system free of dirt. Fluid and debris can cause hydraulic system failures. **DO NOT** mix hydraulic fluids. Incompatible fluids can cause hydraulic system failures.

NO RIDERS
Falling can cause SERIOUS INJURY or DEATH.

CAUTION
KEEP CARS CENTERED
Load vehicles laterally onto platform for balanced lifting.

WARNING
PINCH POINTS
Keep clear of pinch points when lift is moving.

IMPORTANT

Before operating this parking lift, read the **ENTIRE INSTALLATION AND OPERATION MANUAL** as well as all operating and warning instructions shown on the safety placard supplied with the lift.

If any questions arise as to the safety or operation of this lift, contact your property manager, building engineer, parking lift dealer, or call Autostacker at 1 (888) 977-8225.

ALWAYS USE CAUTION WHEN OPERATING THIS LIFT

Keep a clear mind and focus completely on operating the lift in a safe and careful manner.

- **NEVER** override any of the lift's safety features; never allow riders to stand on or be near the lift when in operation.
- **NEVER** operate more than one lift at the same time when multiple lifts are connected to a single power unit.
- **INSPECT THE LIFT PRIOR TO EACH USE.** If any unsafe conditions are found, take the lift out of service and tag it "out of service" until repairs are made or concerns are addressed.
- **NEVER EXCEED THE MAXIMUM RATED LOAD CAPACITY.** The load capacity limits must be strictly followed.
- Do not raise a vehicle if forward wheels are not fully parked within the forward recessed wheel trough. Do not raise a vehicle on the lift if any part of the rear wheels are hanging off the end of the ramp.
- Make sure **BOTH** safety locks are in **LOCKED POSITIONS** before approaching a raised platform or leaving the lift unattended.
- Keep hands, feet, and body parts **CLEAR** of all moving parts and pinch points.
- Check around and above the lift to make sure no objects will interfere with the full range of platform movement and that no persons except the lift operator are within 20 feet. Operators must make sure that pedestrian traffic has been diverted appropriately.
- If the lift platform becomes more than three inches out of level, **STOP IMMEDIATELY** and contact your property manager, building engineer, parking lift dealer, or call Autostacker at 1 (888) 977-8225.

- **NEVER** exceed the maximum rated load capacity. The load capacity limits must be strictly followed.
- Do not raise a vehicle if forward wheels are not fully parked within the forward recessed wheel trough. Do not raise a vehicle on the lift if any part of the rear wheels are hanging off the end of the ramp.
- Make sure **BOTH** safety locks are in **LOCKED POSITIONS** before approaching a raised platform or leaving the lift unattended.
- Keep hands, feet, and body parts **CLEAR** of all moving parts and pinch points.
- Check around and above the lift to make sure no objects will interfere with the full range of platform movement and that no persons except the lift operator are within 20 feet. Operators must make sure that pedestrian traffic has been diverted appropriately.
- If the lift platform becomes more than three inches out of level, **STOP IMMEDIATELY** and contact your property manager, building engineer, parking lift dealer, or call Autostacker at 1 (888) 977-8225.

Only use the lift if you can do so safely!



FRONT

BACK

Q

AUTOSTACKER™ OPERATION INSTRUCTIONS

READ THE ENTIRE AUTOSTACKER INSTALLATION AND OPERATION MANUAL, THE LABELS ON THE UNIT, AND THE WARNING INSTRUCTIONS ON THE OTHER SIDE OF THIS PLACARD BEFORE OPERATING YOUR AUTOSTACKER!

DANGER Always use extreme care around your Autostacker; if used improperly, it can cause injury or death. When the Autostacker is moving, keep all people, animals, and objects at least 30 feet away from it. DO NOT use your Autostacker unless it can be used safely.

PRE-LIFTING STAGE - CHECKLIST

AUTOSTACKER	AREA	OPERATORS	SAFETY
<input checked="" type="checkbox"/> Check the Autostacker for any missing, heavily worn, or damaged parts. DO NOT operate the Autostacker if you find any issues; instead, take it out of service and tag it "out of service"; then contact your parking lift dealer.	<input checked="" type="checkbox"/> Check the area around the Autostacker for obstructions, anything that might block the lift and/or impede proper lifting. DO NOT forget to check above the Autostacker. If you find an obstruction, move it out of the way.	<input checked="" type="checkbox"/> Make sure everyone who is going to operate the Autostacker has been properly trained and has read the entire manual and labels. NEVER allow anyone under the influence of drugs or alcohol to operate the lift.	<input checked="" type="checkbox"/> Make sure everyone who is going to be walking near the Autostacker is aware of its presence and take appropriate safety measures. When raising the Autostacker, DO NOT leave it until it is engaged on SAFETY LOCKS.

LIFTING STAGE

- Confirm the Platform is fully lowered, then drive a vehicle onto the Platform, either nose first or backed in.
- Put the vehicle's forward wheels into the Tire Trough.
- Put the vehicle in park, apply parking brake, move shifter to first gear (if manual transmission), then turn off the engine.
- At the Console, insert your KEY, turn it to On, then press and hold the UP button.
- Watch the vehicle and the Platform as they rise.
- When the Platform passes the desired height, release the UP button. The lift stops rising.
- Press the DOWN button to engage the lift onto the most recently passed SAFETY LOCKS.
- Check to make sure the Platform is engaged on the desired SAFETY LOCKS.
- Drive the lower vehicle in under the Autostacker Platform.

If the lift becomes unstable or the vehicle starts moving on the Platform, press the red Emergency Stop button. Take appropriate action to stabilize the lift and lower the vehicle back down to the ground.

LOWERING STAGE

- If there is a lower vehicle parked under the Platform, carefully drive it out.
- At the Console, insert your KEY, then turn it to On.
- Press and hold the UP button for a second or two to raise the lift off of the SAFETY LOCKS.
- Press and hold the DOWN button.
- When the Platform is resting on the ground, release the DOWN button.
- Carefully drive the top vehicle off the Autostacker Platform.
- Turn the KEY on the Console to Off, then remove it and store it safely.

If you have any questions about how to operate your lift safely, visit autostacker.com/support, email support@autostacker.com or call Autostacker at 1 (888) 977-8225.

PN 590248

AUTOSTACKER™ OPERATION WARNINGS

READ THE ENTIRE AUTOSTACKER INSTALLATION AND OPERATION MANUAL, THE LABELS ON THE UNIT, AND THE WARNING INSTRUCTIONS ON THE OTHER SIDE OF THIS PLACARD BEFORE OPERATING YOUR AUTOSTACKER!

IMPORTANT: Your safety is dependent on reading, understanding, and implementing these Safety Rules. Do not skip over them; read them carefully and follow them!

DANGER Always use extreme care around your Autostacker; if used improperly, it can cause injury or death. When the Autostacker is moving, keep all people, animals, and objects at least 30 feet away from it. DO NOT use your Autostacker unless it can be used safely.

- Always be careful around the Autostacker. When it is lowered, be careful not to trip over it. When it is raised, be careful not to bang your head on the Ramp or Platform. When the Autostacker is moving, keep all people, animals, and objects at least 30 feet away from it.

WARNING Keep hands, feet, and all other body parts clear of the lift at all times. Be especially careful when the lift is raising or lowering. Avoid pinch points or you could be injured.

- When driving a vehicle onto or off of the Platform, keep to the middle of the Platform. Be careful driving onto the Platform with a vehicle that has wet tires; it can be difficult for the wheels to gain traction.
- If the lift platform becomes more than three inches out of level, STOP IMMEDIATELY and contact your property manager, building engineer, parking lift dealer, or call Autostacker at 1 (888) 977-8225.
- Only trained operators may operate the lift. No one else may operate the lift.
- DO NOT walk under your Autostacker, leave the area, or drive a vehicle under the Platform until you have made sure the Autostacker is engaged on its SAFETY LOCKS. When you are operating an Autostacker, only leave it on the ground or engaged on its SAFETY LOCKS.
- Before performing any maintenance on your Autostacker, make sure it is completely disconnected from power. If the lift is reconnected to power before maintenance is complete, you could be injured.

DANGER All work involving wiring must be performed by a licensed, certified Electrician. DO NOT perform any maintenance or troubleshooting on the lift without first making sure that main electrical power has been disconnected from the lift and cannot be re-energized until all procedures are complete.

- Risk of explosion. The lift motor has internal arcing or sparking parts that must not be exposed to flammable vapors.
- Perform regular maintenance on the lift. Keep it clean for better and safer performance. Refer to the Maintenance section of the manual for instructions. Keep all controls dry, clean, and free from grease or oil.
- Do not leave the Autostacker unattended while it is partially raised or lowered. If you are the operator and must leave the area, either lower it back down to the ground or engage on its SAFETY LOCKS.
- Do not go under your Autostacker until you have made sure it is engaged on its SAFETY LOCKS.
- Do not drive a vehicle under a raised Autostacker until you have made sure there is enough clearance for it.
- When you are done using the lift, make sure it is either fully lowered or engaged on its SAFETY LOCKS—then remove the KEY and store it so that it is safe from unauthorized access.
- Whenever possible, walk around a raised Platform, not under it. Safety before convenience.
- If there is more than one way of doing something involving the Autostacker, always take the safer approach.

If you have any questions about how to operate your lift safely, visit autostacker.com/support, email support@autostacker.com or call Autostacker at 1 (888) 977-8225.

PN 590248

R DISCONNECTING SWITCH

PN 590246



T 208-240VAC, 1 Ph, 5 HP, 30A

PN 590589

U 208-240VAC, 3 Ph, 10 HP, 30A

PN 590548

V 480VAC, 3 Ph, 10 HP, 15A

PN 590649

A6S / A6W - OPT 1 Label Positioning

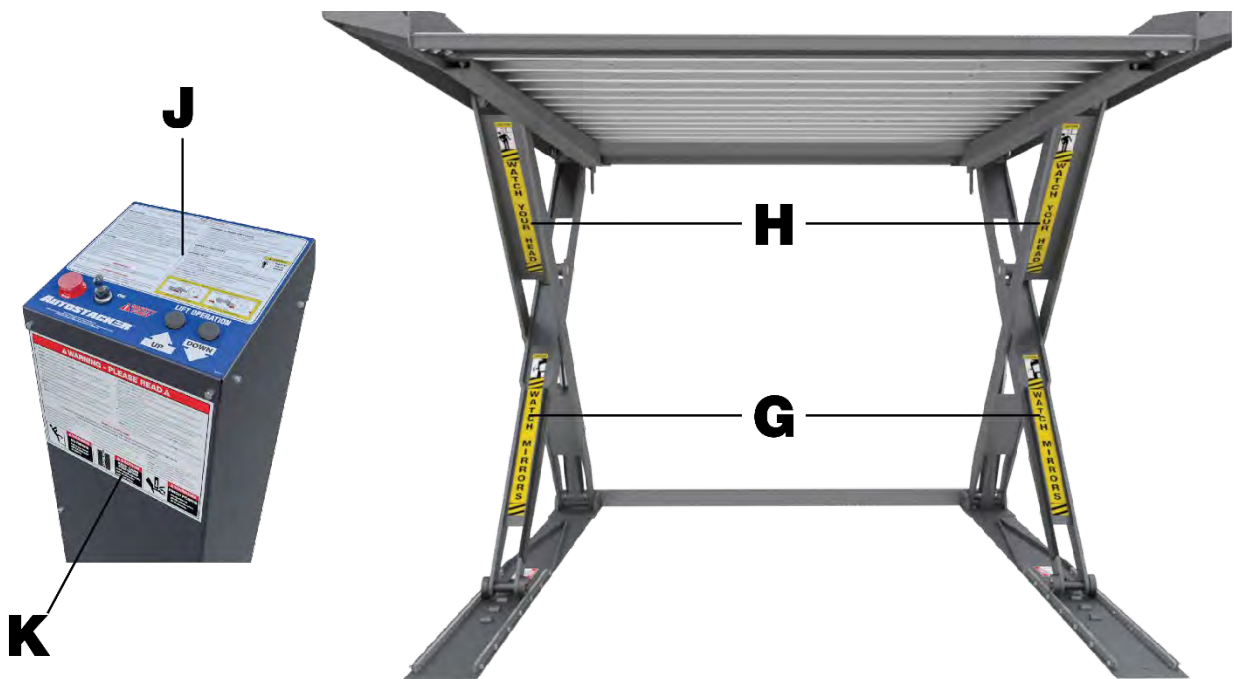
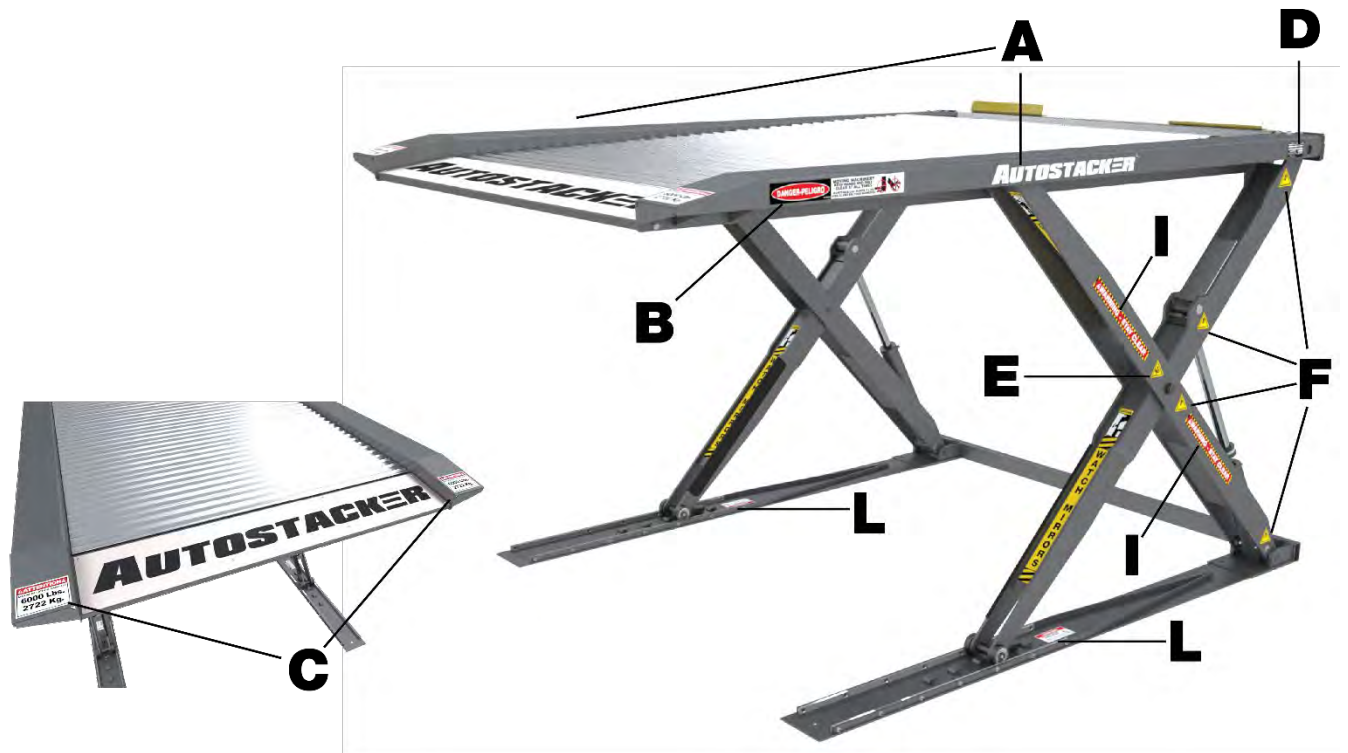

A6S / A6W OPT 2 & 3 - Label Positioning

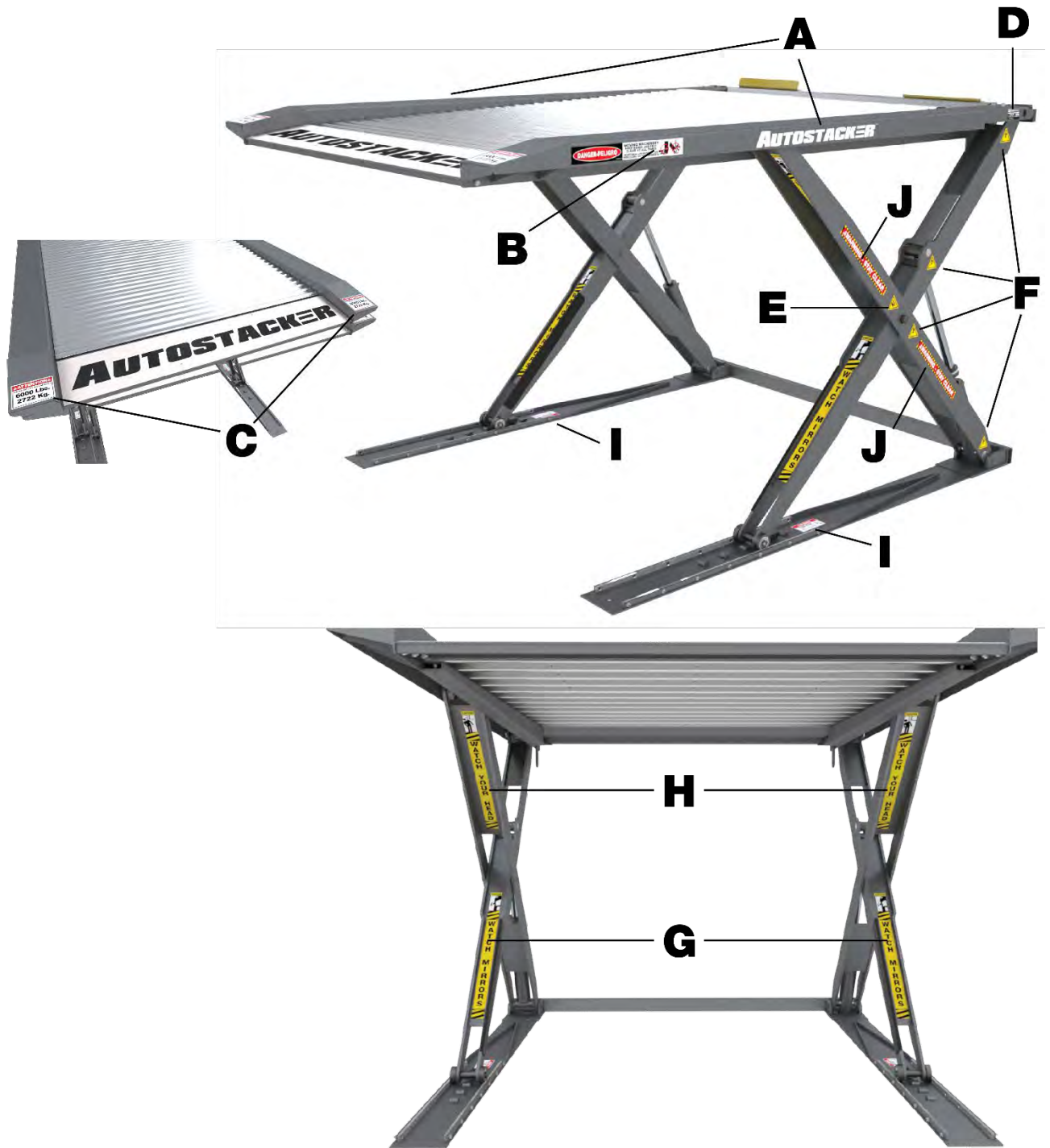

A6S / A6W - OPT 2 & 3 Label Positioning

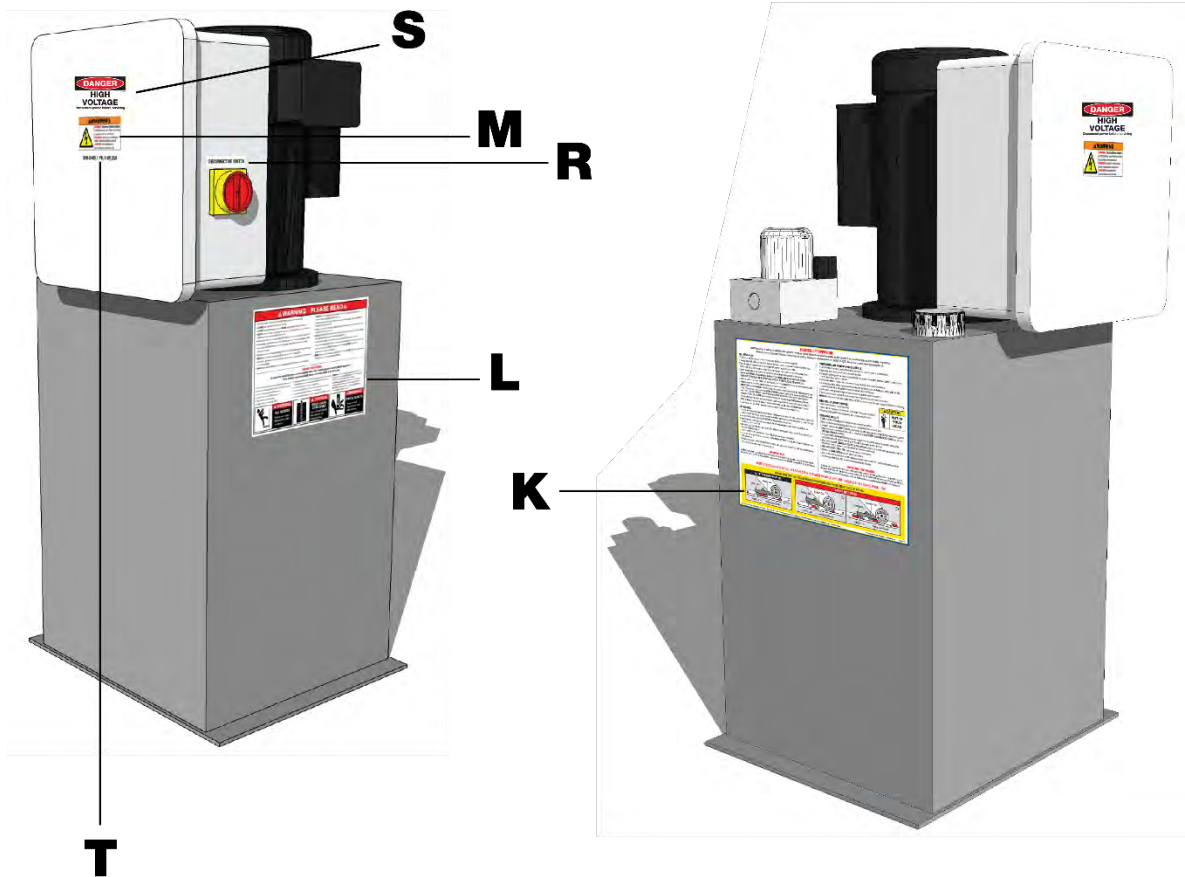

INSIDE OF ELECTRICAL BOX

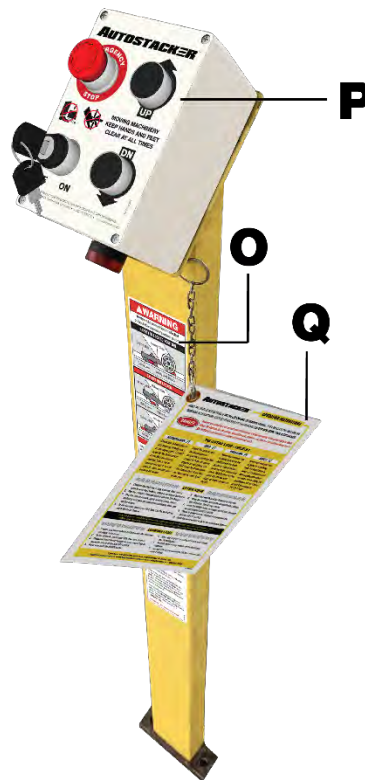

Parts Diagrams

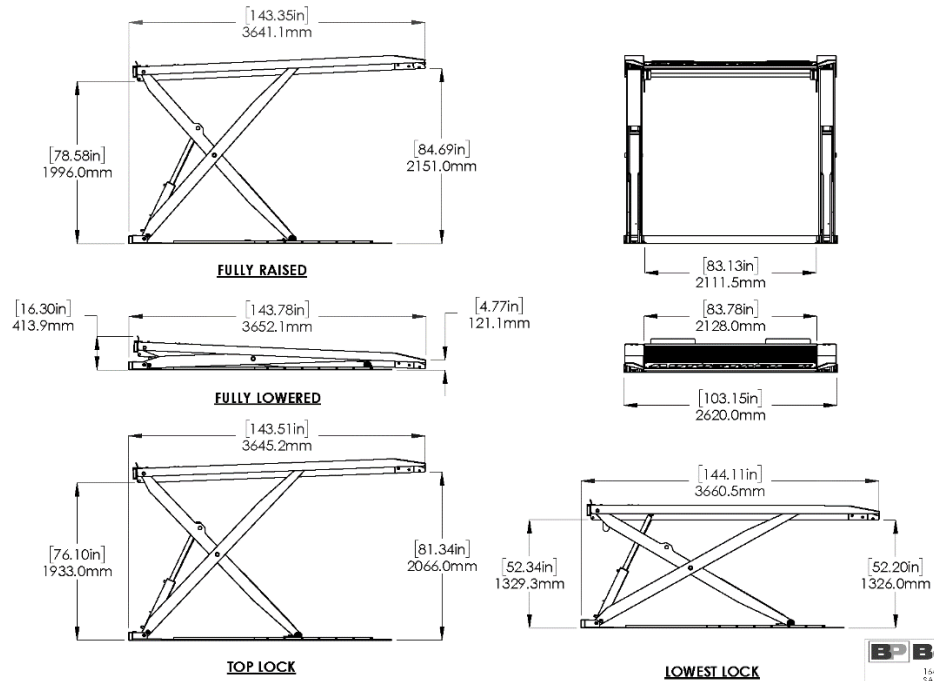

BendPak.
 1645 LEMONWOOD DR.
 SANTA PAULA, CA 95060

TITLE: A6S-OPT1 PRODUCTION LIFT, VER B

REV: D

SCALE: 1:50 SHEET 2 OF 2

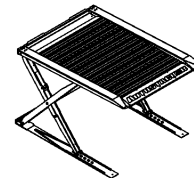
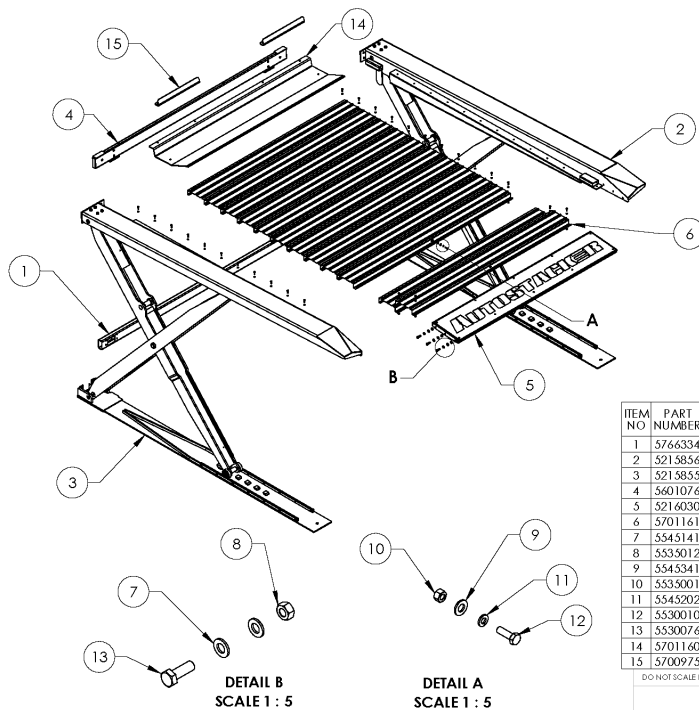

ISOMETRIC VIEW FOR REFERENCE ONLY
DO NOT SCALE

ITEM NO	PART NUMBER	DESCRIPTION	QTY	REV
1	5766334	AUTOSTACKER CONNECTOR TUBE REVERSIBLE NARROW	1	B
2	5215856	AUTOSTACKER RIGHT TILT LEG ASSEMBLY	1	C
3	5215855	AUTOSTACKER LEFT TILT LEG ASSEMBLY	1	D
4	5601076	AUTOSTACKER TOP CONNECTOR TUBE WELDMENT NARROW	1	B
5	5216030	A6S DRIVE UP RAMP ASSEMBLY	1	A
6	5701161	AUTOSTACKER RAMP SECTION NARROW	12	F
7	5545141	WASHER M12 x 24 FLAT CL 10.9	12	--
8	5535012	NUT M12x1.75 NL	6	--
9	5545341	WASHER M10 x Ø20 FLAT	11	--
10	5535001	NUT M8 x 1.25 NL	37	--
11	5545202	WASHER M8 x Ø15 SL	37	--
12	5530010	HHB M8 x 1.25 x 25	37	--
13	5530076	HHB M12 x 1.75 x 35mm	6	--
14	5701160	AUTOSTACKER FRONT WHEEL PLATE NARROW	1	E
15	5700973	AUTOSTACKER TIRE STOP	2	B

DO NOT SCALE DRAWING

NAME: TS DATE: 06/24/2019

DRAWN BY: TS

CHECKED BY: 04/08/2021

THIRD ANGLE PROJECTION

BendPak.
 1645 LEMONWOOD DR.
 SANTA PAULA, CA 95060

TITLE: A6S SUPERSTRUCTURE

REV: E

SCALE: 1:40 SHEET 1 OF 1

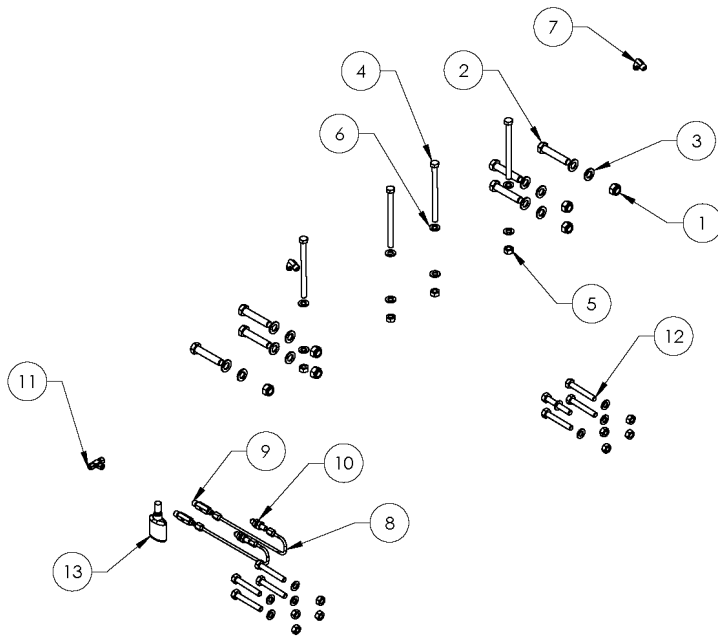

ITEM NO	PART NUMBER	DESCRIPTION	QTY	REV
1	5535008	NUT M16 x 2 NL	6	--
2	5530299	HHB M16 x 2.0 x 80 CL 8.8	6	--
3	5545025	WASHER M16 x 30mm FLAT	12	--
4	5530189	HHB M12 x 1.75 x 160	4	--
5	5535012	NUT M12x1.75 NL	12	--
6	5545141	WASHER M12 x 24 FLAT CL 10.9	16	--
7	5550083	FTG ELB -04 COMP x -04 NPT	2	--
8	5215732	AUTOSTACKER HYDRAULIC LINE ASSEMBLY	2	D
9	5550603	VELOCITY FUSE	2	--
10	5550111	FIG NPL BLKHD -04 JIC x -04 JIC	2	--
11	5550395	FTG TEE -04 COMP x -04 COMP x -04 COMP	1	--
12	5530393	HHB M12 x 1.75 x 80	8	--
13	5580012	LIQUID PTFE THREAD SEALANT 4 .oz	1	--

DO NOT SCALE DRAWING

DRAWN	JM	02/08/2016
CHECKED	OR	03/10/2020

DIMENSIONS ARE IN MM

THIRD ANGLE PROJECTION

PROPRIETARY AND CONFIDENTIAL
THE INFORMATION CONTAINED IN THIS DRAWING IS THE SOLE PROPERTY OF BENDPAK INC. ANY REPRODUCTION IN PART OR AS A WHOLE WITHOUT THE WRITTEN PERMISSION OF BENDPAK INC. IS PROHIBITED.

BendPak
1645 LEMONWOOD DR.
SANTA PAULA, CA 92360

TITLE: AUTOSTACKER PARTS BAG

SIZE DWG. NO. REV
A 5174017 L

SCALE: 1:12 SHEET 1 OF 1

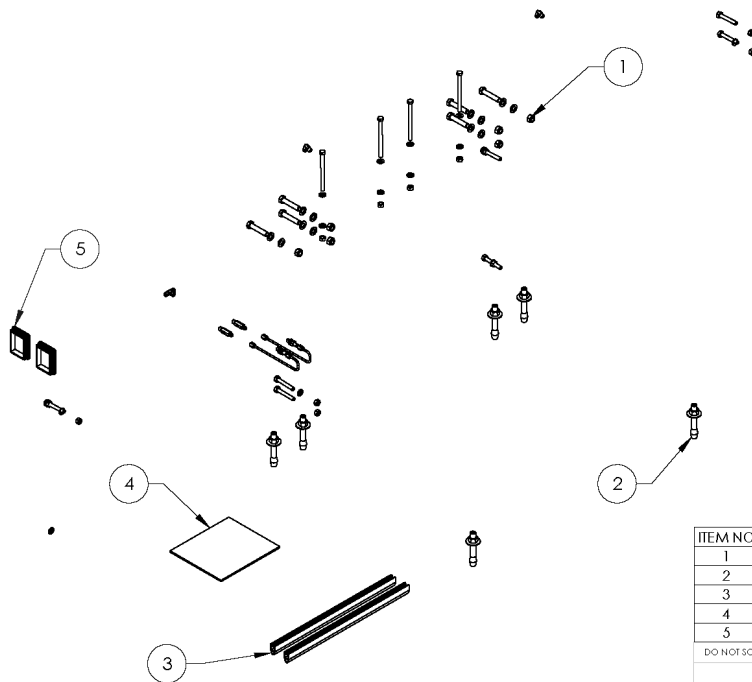

ITEM NO	PART NUMBER	DESCRIPTION	QTY	REV
1	5174017	AUTOSTACKER PARTS BAG	1	K
2	5530456	AB 3/4" x 4 - 3/4"	6	--
3	5520031	FOAM RUBBER EDGE TRIM	2*	--
4	5900002	AUTOSTACKER INSTALLATION MANUAL	1	--
5	5715196	XPR POLYETHYLENE COVER BLOCK 105 x 80	2	D

DO NOT SCALE DRAWING

DRAWN	JM	02/08/2016
CHECKED	CA	07/31/2019

DIMENSIONS ARE IN MM

THIRD ANGLE PROJECTION

PROPRIETARY AND CONFIDENTIAL
THE INFORMATION CONTAINED IN THIS DRAWING IS THE SOLE PROPERTY OF BENDPAK INC. ANY REPRODUCTION IN PART OR AS A WHOLE WITHOUT THE WRITTEN PERMISSION OF BENDPAK INC. IS PROHIBITED.

BendPak
1645 LEMONWOOD DR.
SANTA PAULA, CA 92360

TITLE: A6S PARTS BOX

SIZE DWG. NO. REV
A 5250363 M

SCALE: 1:18 SHEET 1 OF 1

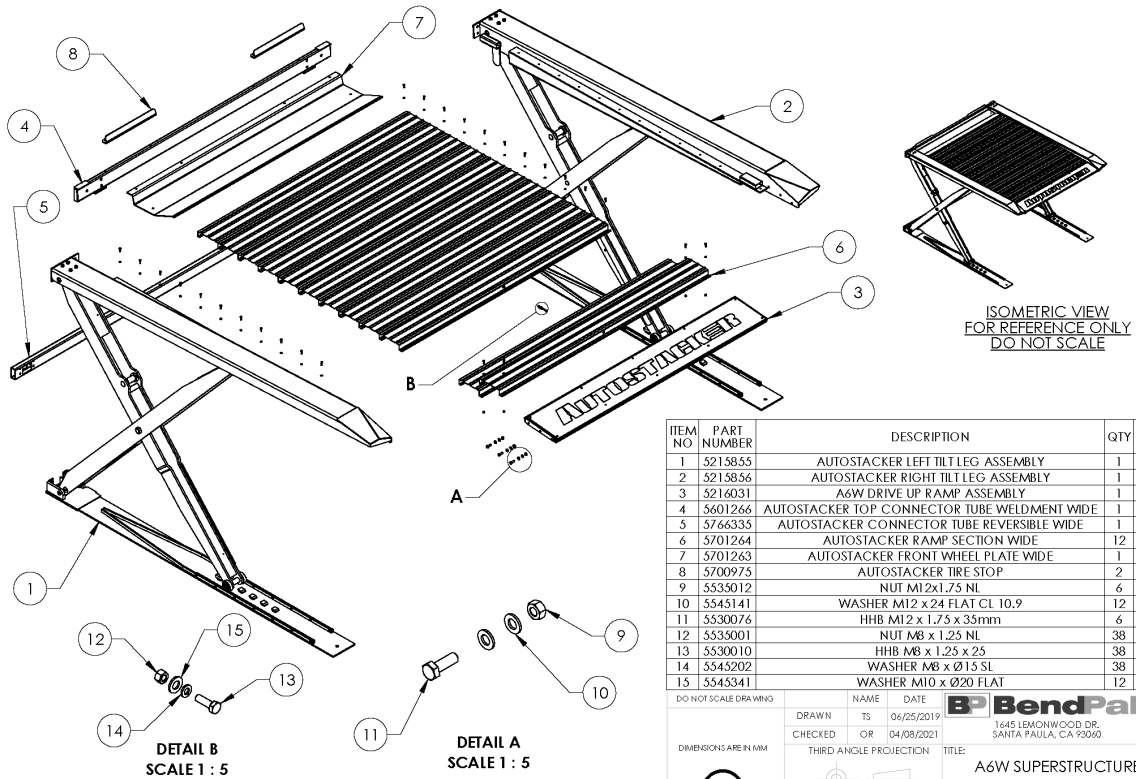

ITEM NO	PART NUMBER	DESCRIPTION	QTY	REV
1	5215855	AUTOSTACKER LEFT TILT LEG ASSEMBLY	1	D
2	5215856	AUTOSTACKER RIGHT TILT LEG ASSEMBLY	1	C
3	5214031	A6W DRIVE UP RAMP ASSEMBLY	1	A
4	5601266	AUTOSTACKER TOP CONNECTOR TUBE WELDMENT WIDE	1	B
5	5746335	AUTOSTACKER CONNECTOR TUBE REVERSIBLE WIDE	1	B
6	5701264	AUTOSTACKER RAMP SECTION WIDE	12	C
7	5701263	AUTOSTACKER FRONT WHEEL PLATE WIDE	1	C
8	5700975	AUTOSTACKER TIRE STOP	2	B
9	5535012	NUT M12x1.75 NL	6	--
10	5545141	WASHER M12 x 24 FLAT CL 10.9	12	--
11	5530076	HHB M12 x 1.75 x 35mm	6	--
12	5535001	NUT M8 x 1.25 NL	38	--
13	5530010	HHB M8 x 1.25 x 25	38	--
14	5545202	WASHER M8 x Ø15 SL	38	--
15	5545341	WASHER M10 x Ø20 FLAT	12	--

DO NOT SCALE DRAWING

DRAWN	TS	06/25/2019	 1445 LEMONWOOD DR. SANTA PAULA, CA 93060
CHECKED	OR	04/08/2021	
THIRD ANGLE PROJECTION			TITLE:
			A6W SUPERSTRUCTURE
SEE DWG. NO.		REV	
A		5245070	E
SCALE: 1:35			SHEET 1 OF 1

PROPRIETARY AND CONFIDENTIAL
THE INFORMATION CONTAINED IN THIS DRAWING IS THE SOLE PROPERTY OF BENDPAK, INC. ANY REPRODUCTION IN PART OR AS A WHOLE WITHOUT THE WRITTEN PERMISSION OF BENDPAK, INC. IS PROHIBITED.

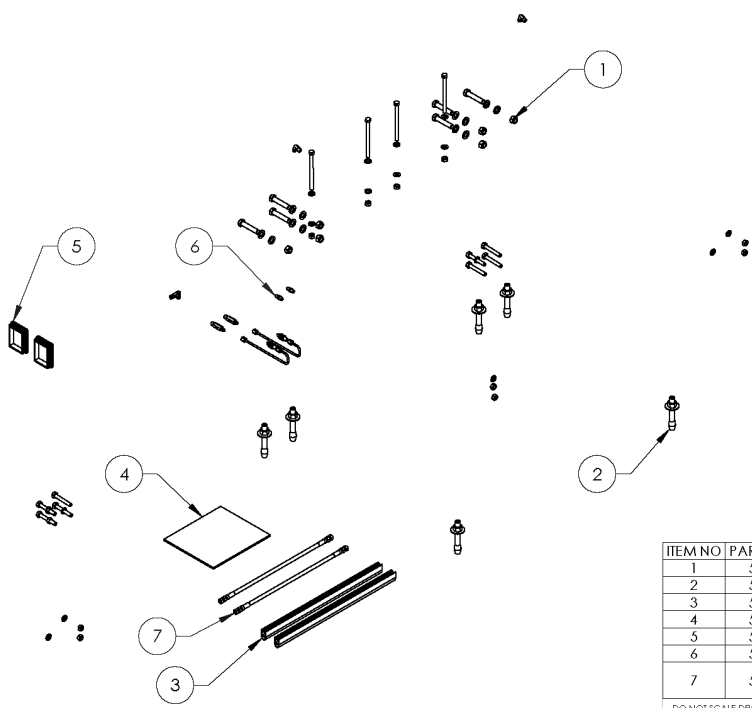

ITEM NO	PART NUMBER	DESCRIPTION	QTY	REV
1	5174017	AUTOSTACKER PARTS BAG	1	K
2	5530456	AB 3/4" x 4 - 3/4"	6	--
3	5520031	FOAM RUBBER EDGE TRIM	2*	--
4	5900002	AUTOSTACKER INSTALLATION MANUAL	1	--
5	5715196	XPR POLYETHYLENE COVER BLOCK 105 x 80	2	D
6	5550095	FTG NPL-04 JIC x-04 JIC	2	--
7	5570065	XPR-10A HYDRAULIC HOSE EXTENSION ASSY Ø6.35 x 203mm DS	2	C

DO NOT SCALE DRAWING

DRAWN	TS	05/23/2019	 1445 LEMONWOOD DR. SANTA PAULA, CA 93060
CHECKED	CA	07/31/2019	
THIRD ANGLE PROJECTION			TITLE:
			A6W PARTS BOX
SEE DWG. NO.		REV	
A		5250277	A
SCALE: 1:18			SHEET 1 OF 1

PROPRIETARY AND CONFIDENTIAL
THE INFORMATION CONTAINED IN THIS DRAWING IS THE SOLE PROPERTY OF BENDPAK, INC. ANY REPRODUCTION IN PART OR AS A WHOLE WITHOUT THE WRITTEN PERMISSION OF BENDPAK, INC. IS PROHIBITED.

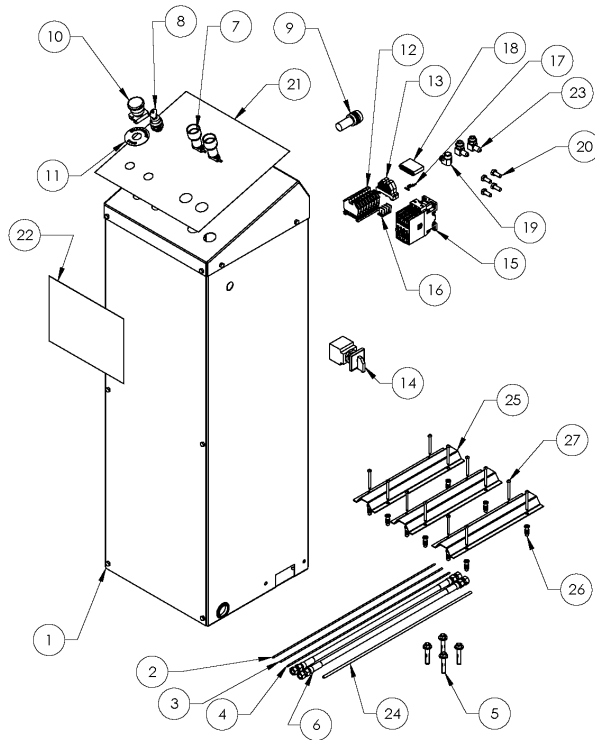

ITEM NO.	PART NUMBER	DESCRIPTION	QTY	REV
1	5215723	AUTOSTACKER POWER UNIT CONSOLE ASSEMBLY	1	E
2	5520126	WIRE, AWG 12, GREEN, STRANDED, PVC	915mm*	--
3	5520123	WIRE, AWG 12, BLACK, STRANDED, PVC	915mm*	--
4	5520657	WIRE, AWG 12, WHITE, STRANDED, PVC	915mm*	--
5	5530326	AB Ø3/8" x 2-1/4"	4	--
6	5570220	HOSE ASSEMBLY Ø6.4 x 5080mm DS	2	B
7	5525586	CONSOLE PUSH BUTTON ASSEMBLY	2	--
8	5520403	SELECTOR SWITCH KEY OPERATED 2 POSITION	1	--
9	5520503	LIGHTED WARNING BUZZER ASSY: 220V	1	--
10	5520401	PUSH BUTTON, 22mm, EMERGENCY	1	--
11	5520402	LEGEND PLATE 60mm E-STOP	1	--
12	5520434	TERMINAL BLOCK, 6AWG, 65A, GRAY	8	--
13	5520438	TERMINAL BLOCK END BRACKET, SCREW DOWN, 9mm WIDE	2	--
14	5520492	22mm PANEL MOUNT DISCONNECT SWITCH: 3ph 25A	1	--
15	5520491	3 Ph CONTACTOR 45A	1	--
16	5520442	TERMINAL JUMPER DR-5536 FOR DN-T6	4	--
17	5520493	MOLEX MALE CRIMP 10-12 AWG	1	--
18	5520494	HEADERS & WIRES HOUSING SUPER SABER 7.5 MM HSG6CKT	1	--
19	5530089	FIG ELB -04 COMP x-06 NPT	1	--
20	5530304	HHB M6 x 1.25 x 20	4	--
21	5906011	CONSOLE LIFT OPERATION LABEL	1	--
22	5906012	CONSOLE WARNING LABEL	1	--
23	5530103	FIG ELB -04 JIC -06 ORB	2	--
24	5570795	1/4" POLY-FLO TUBING	5000mm*	--
25	5701655	HYDRAULIC HOSE COVER 305mm	3	A
26	5535119	M5 x 30mm FLOR ANCHOR	12	--
27	5530312	RHPS M5 x 55mmL	12	--

DO NOT SCALE DRAWING

NAME: TS DATE: 04/04/2018

DRAWN: TS 04/04/2018

CHECKED: CA 07/30/2019

THIRD ANGLE PROJECTION

SMILEY FACE

PROPRIETARY AND CONFIDENTIAL

THE INFORMATION CONTAINED IN THIS DRAWING IS THE SOLE PROPERTY OF BENDPAK INC. ANY REPRODUCTION IN PART OR AS A WHOLE WITHOUT THE WRITTEN PERMISSION OF BENDPAK INC. IS PROHIBITED.

BendPak
1645 LEMONWOOD DR.
SANTA PAULA, CA 93060

TITLE: AUTOSTACKER 220V POWER UNIT KIT

SEE DWG. NO. A 5105324 REV D

SCALE: 1:10 SHEET 1 OF 2

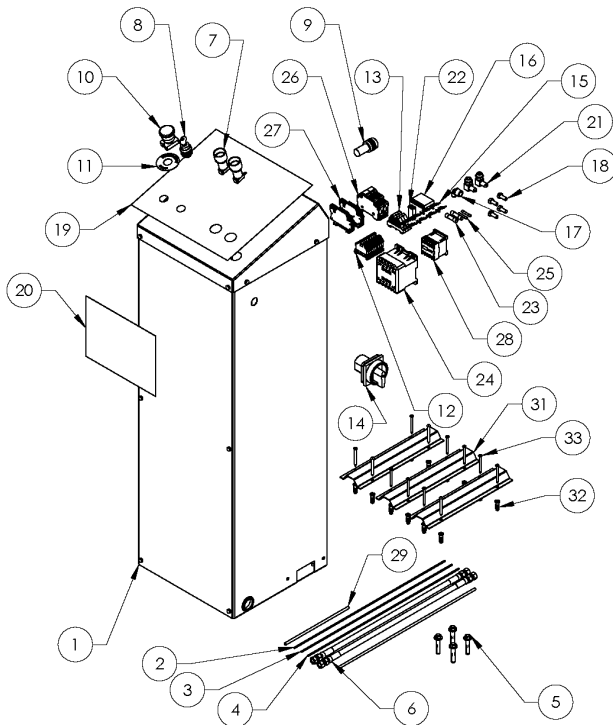

ITEM NO.	PART NUMBER	DESCRIPTION	QTY	REV
1	5215822	AUTOSTACKER POWER UNIT CONSOLE ASSEMBLY 380VAC	1	A
2	5520126	WIRE, AWG 12, GREEN, STRANDED, PVC	915mm*	--
3	5520123	WIRE, AWG 12, BLACK, STRANDED, PVC	915mm*	--
4	5520657	WIRE, AWG 12, WHITE, STRANDED, PVC	915mm*	--
5	5530326	AB Ø3/8" x 2-1/4"	4	--
6	5570220	HOSE ASSEMBLY Ø6.4 x 5080mm DS	2	B
7	5525586	CONSOLE PUSH BUTTON ASSEMBLY	2	--
8	5520403	SELECTOR SWITCH KEY OPERATED 2 POSITION	1	--
9	5520499	AUDIBLE BUZZER, 22mm, RED LED, 24V	1	--
10	5520401	PUSH BUTTON, 22mm, EMERGENCY	1	--
11	5520402	LEGEND PLATE 60mm E-STOP	1	--
12	5520436	TERMINAL BLOCK 10AWG, 30A, GRAY	10	--
13	5520438	TERMINAL BLOCK END BRACKET, SCREW DOWN, 9mm WIDE	3	--
14	5520036	PANEL MOUNT DISCONNECT SWITCH: 3ph	1	--
15	5520493	MOLEX MALE CRIMP 10-12 AWG	8	--
16	5520494	HEADERS & WIRES HOUSING SUPER SABER 7.5 MM HSG6CKT	1	--
17	5530004	FIG ELB 1/4 TUBE INS 3/8 NPT	1	--
18	5530304	HHB M6 x 1.25 x 20	4	--
19	5906011	CONSOLE LIFT OPERATION LABEL	1	--
20	5906012	CONSOLE WARNING LABEL	1	--
21	5530103	FIG ELB -04 JIC -06 ORB	2	--
22	5520045	MOLEX CONNECTOR 2 PORT	1	--
23	5520043	FUSE 1A TIME DELAY 600VAC	2	--
24	5520044	TRANSFORMER, 380/24VAC, 75V; 1PH	1	--
25	5520581	FUSE 5A, 1-1/4" x 1-1/4"	2	--
26	5520054	2 POLE FUSE HOLDER, 600VAC, 30A	1	--
27	5520433	FUSE HOLDER 6AWG 30A	2	--
28	5520046	CONTACTOR, 380VAC, 5HP COIL 24VAC	1	--
29	5520015	SLEEVE, BLACK PVC, 6mm	915mm*	--
30	5570795	1/4" POLY-FLO TUBING	5000mm*	--
31	5701655	HYDRAULIC HOSE COVER 305mm	3	A
32	5535119	M5 x 30mm FLOR ANCHOR	12	--
33	5530312	RHPS M5 x 55mmL	12	--

DO NOT SCALE DRAWING

NAME: TS DATE: 02/12/2019

DRAWN: TS 02/12/2019

CHECKED: OR 07/23/2020

THIRD ANGLE PROJECTION

SMILEY FACE

PROPRIETARY AND CONFIDENTIAL

THE INFORMATION CONTAINED IN THIS DRAWING IS THE SOLE PROPERTY OF BENDPAK INC. ANY REPRODUCTION IN PART OR AS A WHOLE WITHOUT THE WRITTEN PERMISSION OF BENDPAK INC. IS PROHIBITED.

BendPak
1645 LEMONWOOD DR.
SANTA PAULA, CA 93060

TITLE: AUTOSTACKER 380V POWER UNIT KIT

SEE DWG. NO. A 5105344 REV D

SCALE: 1:12 SHEET 1 OF 4

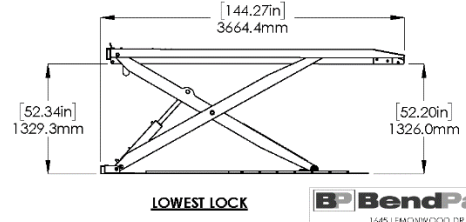
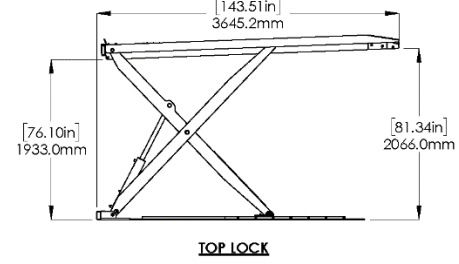
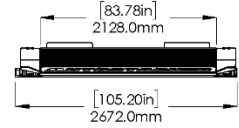
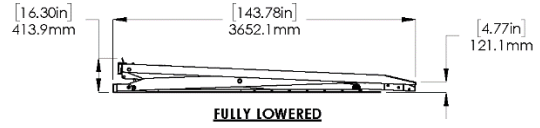
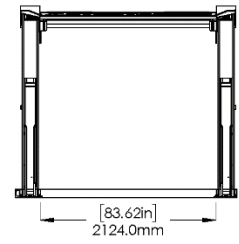
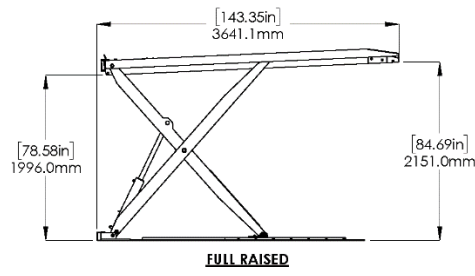

EP BendPak.
 1645 LEMONWOOD DR.
 SANTA PAULA, CA 93040

TITLE: A6S-OPT3 PRODUCTION LIFT, VER B

SEE DWG. NO.	REV
A 5260595	D

SCALE: 1:50 SHEET 2 OF 2

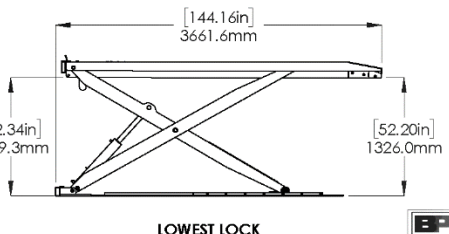
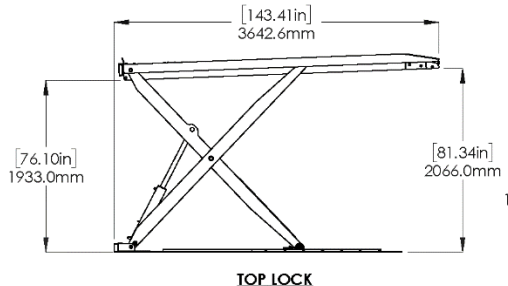
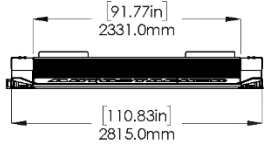
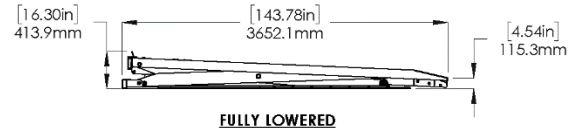
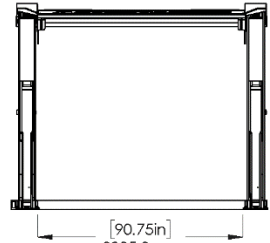
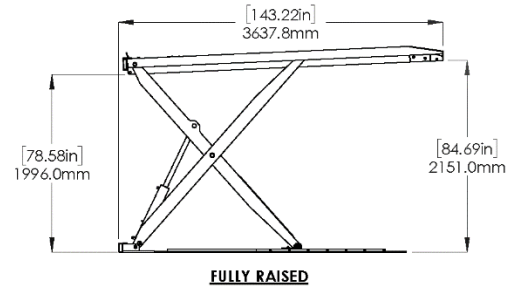

EP BendPak.
 1645 LEMONWOOD DR.
 SANTA PAULA, CA 93040

TITLE: A6W-OPT3 PRODUCTION LIFT, VER B

SEE DWG. NO.	REV
A 5260596	D

SCALE: 1:50 SHEET 2 OF 2

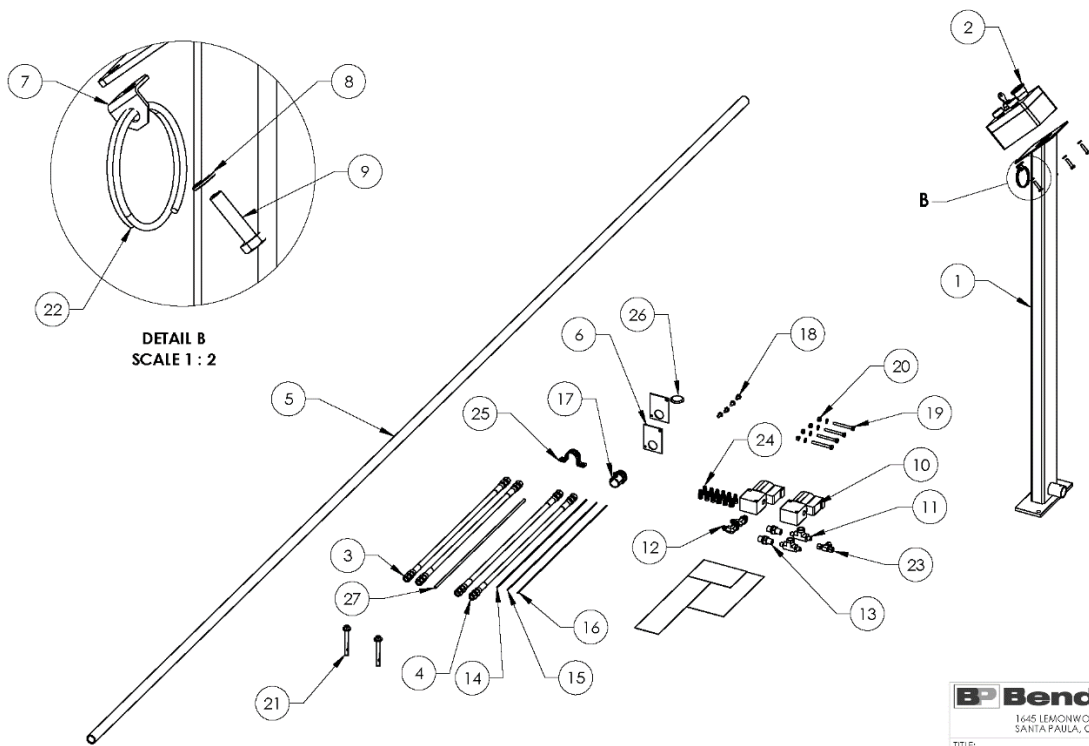

BendPak
 1645 LEMONWOOD DR.
 SANTA PAULA, CA 93050

TITLE: AUTOSTACKER-OPT3 MPU CONTROL KIT

SIZE	DWG. NO.	REV
A	5215836	E

SCALE: 1:12 SHEET 2 OF 5

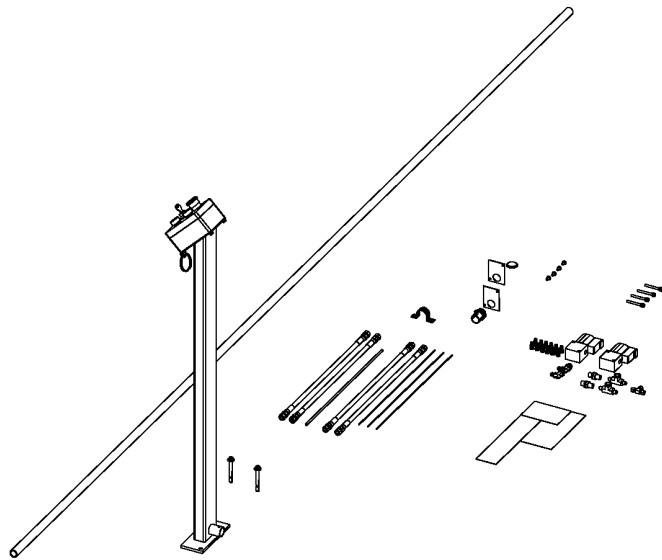

ITEM NO	PART NUMBER	DESCRIPTION	QTY	REV
1	5601365	AUTOSTACKER CONTROL STAND WELDMENT FRONT MOUNT	1	B
2	5601240	AUTOSTACKER CONTROL BOX ASSEMBLY	1	C
3	5570229	HOSE ASSEMBLY Ø6.35 x 2743mm DS	2	B
4	5570091	HYDRAULIC HOSE ASSY Ø6.35 x 381mm DS	2	A
5	5755088	AUTOSTACKER CONDUIT TUBE	1	A
6	5737129	AUTOSTACKER-OPT3 CONDUIT COVER PLATE	2	B
7	5701571	MPU STAND BRACKET PLACARD HOLDER	1	A
8	5545005	M6 FLAT WASHER	8	--
9	5530756	HHB M6 x 1 x 25	4	--
10	5590245	2 WAY D.B. VALVE 24V AC/DC COIL	2	--
11	5550047	FTG TEE -04 JIC-04 JIC-04 F NPT	2	--
12	5550103	FTG ELB -04 JIC -06 ORB	2	--
13	5550093	FTG NPL -06 ORB x-04 NPT	2	--
14	5520072	WIRE, AWG 14-6, SOOW	3050mm*	--
15	5520038	WIRE, AWG 16-2, SJOOW	4572mm*	--
16	5520073	WIRE, AWG 16-8, SOOW	5486mm*	--
17	5550069	EMT CONDUIT FITTING	1	--
18	5530079	BPHS M6 x 1.0x10	4	--
19	5530321	HHB M6 x 1.0 x 55	4	--
20	5535112	NUT M6 x 1.0	4	--
21	5327100	AB Ø3/8" x 2-1/4"	2	--
22	5580219	KEYRING 56mm x 3mm	1	--
23	5550395	FTG TEE -04 COMP x-04 COMP x-04 COMP	1	--
24	5520500	ORANGE WIRE CONNECTOR	12	--
25	5505068	1" PIPE STRAP	1	--
26	5580011	PE HOLE PLUG 25mm	1	--
27	5570795	1/4" POLY-FLO TUBING	5000mm*	--
--	5905399	MULTI UNIT WARNING LABEL	1	--
--	5905394	MULTI UNIT CONTROL LABEL, VERTICAL	1	--
--	5905398	MPU STAND PLACARD	1	--

DO NOT SCALE DRAWING

DRAWN	TM	03/17/2019
CHECKED	OR	04/08/2021

DIMENSIONS ARE IN MM

THIRD ANGLE PROJECTION

BendPak
 1645 LEMONWOOD DR.
 SANTA PAULA, CA 93060

TITLE: AUTOSTACKER-OPT3 MPU CONTROL KIT

SIZE	DWG. NO.	REV
A	5215836	E

SCALE: 1:15 SHEET 1 OF 5

PROPRIETARY AND CONFIDENTIAL
 THE INFORMATION CONTAINED IN THIS DRAWING IS THE SOLE PROPERTY OF BENDPAK INC. ANY REPRODUCTION IN WHOLE OR IN PART WITHOUT THE WRITTEN PERMISSION OF BENDPAK INC. IS PROHIBITED.

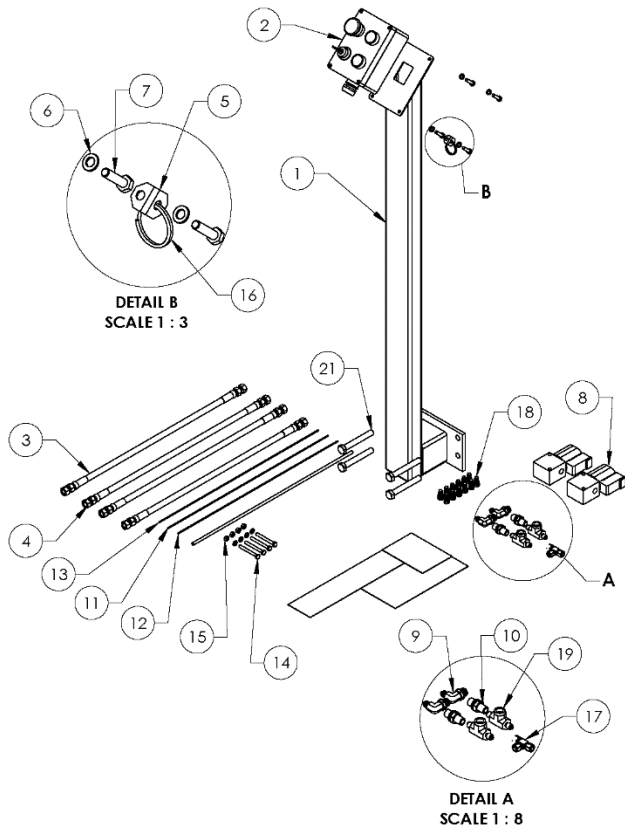

ITEM NO	PART NUMBER	DESCRIPTION	QTY	REV
1	5601239	AUTOSTACKER CONTROL STAND WELDMENT	1	D
2	5601240	AUTOSTACKER CONTROL BOX ASSEMBLY	1	C
3	5570089	HYDRAULIC HOSE ASSY Ø6.35 x 2667mm DS	2	A
4	5570240	HYDRAULIC HOSE ASSY Ø6.35 x 431mm DS	2	A
5	5701571	MPU STAND BRACKET PLACARD HOLDER	1	A
6	5545005	M6 FLAT WASHER	8	--
7	5530756	HHB M6 x 1 x 25	4	--
8	5590245	2 WAY D.B.- VALVE 24V AC/DC COIL	2	--
9	5550103	FTG ELB-04 JIC-04 ORB	2	--
10	5550093	FTG NPL-04 ORB x-04 NPT	2	--
11	5520072	WIRE, AWG 14-6, SOOW	3050mm*	--
12	5520038	WIRE, AWG 16-2, SJOOV	3050mm*	--
13	5520073	WIRE, AWG 16-8, SOOW	1524mm*	--
14	5530321	HHB M6 x 1.0 x 55	4	--
15	5535112	NUT M6 x 1.0	4	--
16	5580002	KEYRING 27mm x 2mm	1	--
17	5550395	FTG TEE-04 COMP x-04 COMP x-04 COMP	1	--
18	5520500	ORANGE WIRE CONNECTOR	12	--
19	5550047	FTG TEE-04 JIC-04 JIC-04 F NPT	2	--
20	5570795	1/4" POLY-FLO TUBING	5000mm*	--
21	5530009	HHB M12 x 1.75 x 90 C18.8	4	--
--	5905399	MULTI UNIT WARNING LABEL	1	--
--	5905394	MULTI UNIT CONTROL LABEL, VERTICAL	1	--
--	5905398	MPU STAND PLACARD	1	--

DO NOT SCALE DRAWING

NAME	DATE	 1645 LEMONWOOD DR. SANTA PAULA, CA 93060
DRAWN TS	03/05/2018	
CHECKED OR	04/08/2021	

DIMENSIONS ARE IN MM

THIRD ANGLE PROJECTION

TITLE: AUTOSTACKER-OPT2 MPU CONTROL KIT

SEE DWG. NO. 5215713 REV K

SCALE: 1:10 SHEET 1 OF 4

PROPRIETARY AND CONFIDENTIAL
THE INFORMATION CONTAINED IN THIS DRAWING IS THE SOLE PROPERTY OF BENDPAK, INC. ANY REPRODUCTION IN PART OR AS A WHOLE WITHOUT THE WRITTEN PERMISSION OF BENDPAK, INC. IS PROHIBITED.

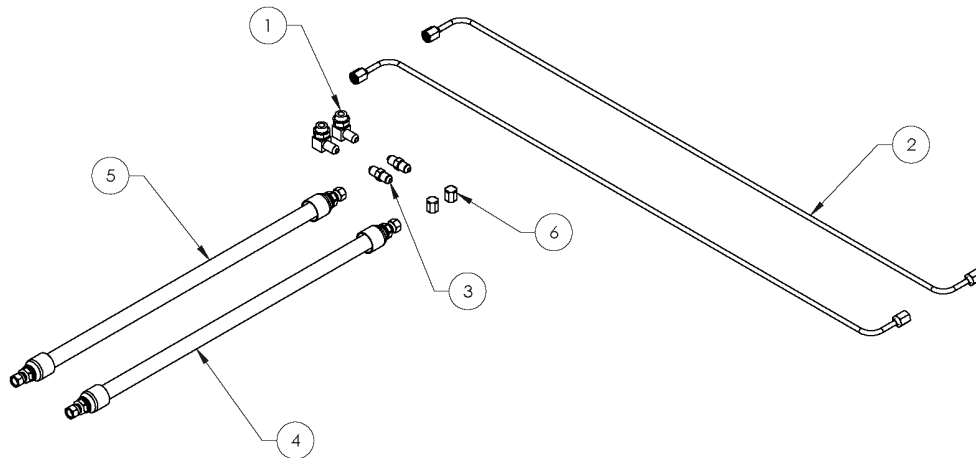

ITEM NO.	PART NUMBER	DESCRIPTION	QTY	REV
1	5550103	FTG ELB-04 JIC-04 ORB	2	--
2	5215764	AUTOSTACKER MPU HYDRAULIC LINE ASSEMBLY	2	B
3	5550095	FTG NPL-04 JIC x-04 JIC	2	--
4	5570230	SHOCK HOSE ASSEMBLY Ø10 x 4100mm DS	1	A
5	5570098	SHOCK HOSE ASSY Ø10 x 1800mm DS	1	A
6	5550054	THREADED FITTING CAP; -04 JIC	2	--

DO NOT SCALE DRAWING

NAME	DATE	 1645 LEMONWOOD DR. SANTA PAULA, CA 93060
DRAWN TS	08/28/2018	
CHECKED CA	07/30/2019	

DIMENSIONS ARE IN MM

THIRD ANGLE PROJECTION

TITLE: MTE MASTER POWER UNIT PLUMBING KIT

SEE DWG. NO. 5174028 REV B

SCALE: 1:6 SHEET 1 OF 1

PROPRIETARY AND CONFIDENTIAL
THE INFORMATION CONTAINED IN THIS DRAWING IS THE SOLE PROPERTY OF BENDPAK, INC. ANY REPRODUCTION IN PART OR AS A WHOLE WITHOUT THE WRITTEN PERMISSION OF BENDPAK, INC. IS PROHIBITED.

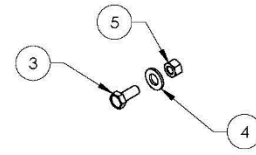
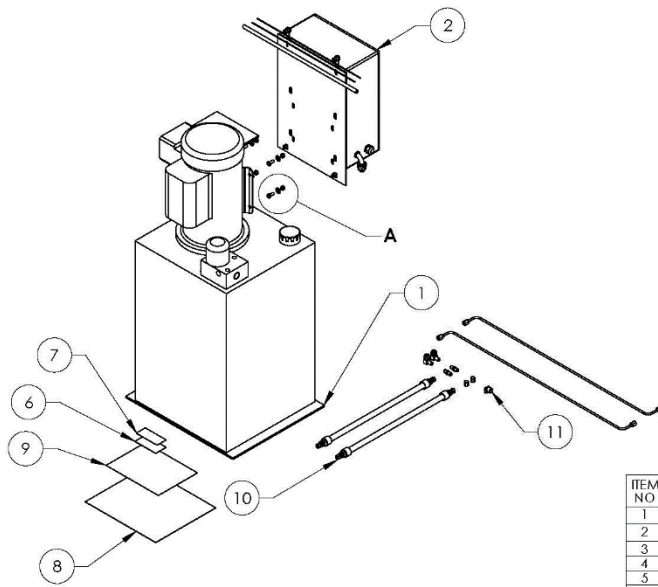

DETAIL A
SCALE 1 : 4

ITEM NO	PART NUMBER	DESCRIPTION	QTY	REV
1	5585007	MULTI UNIT 35 gal. 5 HP, 230V AC 60HZ, 1 ph	1	--
2	5620627	AUTOSTACKER MPU 1ph ELECTRICAL BOX ASSEMBLY	1	C
3	5530304	HHB M8 x 1.25 x 20	4	--
4	5545341	WASHER M10 x Ø20 FLAT	4	--
5	5535001	NUT M8 x 1.25 NL	4	--
6	5905025	WARNING ELECTRICAL SHOCK LABEL	1	--
7	5905045	RISK OF FIRE LABEL	1	--
8	5905397	CONSOLE OPERATION LABEL	1	--
9	5906012	CONSOLE WARNING LABEL	1	--
10	5174028	MIE MASTER POWER UNIT PLUMBING KIT	1	B
11	5550004	FIG ELB 1/4 TUBE INS 3/8 NPT	1	--

DO NOT SCALE DRAWING

DIMENSIONS ARE IN MM

NAME: _____ DATE: _____
 DRAWN: TS 03/23/2018
 CHECKED: OR 07/23/2020

THIRD ANGLE PROJECTION

PROPRIETARY AND CONFIDENTIAL
 THE INFORMATION CONTAINED IN THIS DRAWING IS THE SOLE PROPERTY OF BENDPAK INC. ANY REPRODUCTION IN PART OR AS A WHOLE WITHOUT THE WRITTEN PERMISSION OF BENDPAK INC. IS PROHIBITED.

BendPak.
 1645 LEMONWOOD DR.
 SANTA PAULA, CA 93060

TITLE: AUTOSTACKER 1 PHASE MPU KIT

SIZE DWG. NO. REV
 A 5105209 D

SCALE: 1:12 SHEET 1 OF 1

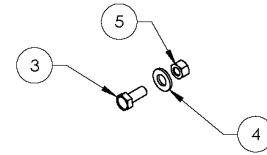
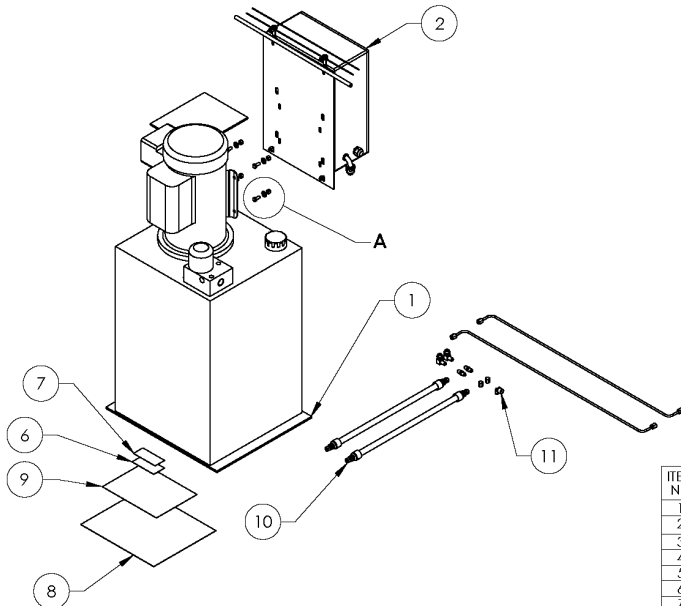

DETAIL A
SCALE 1 : 4

ITEM NO	PART NUMBER	DESCRIPTION	QTY	REV
1	5585507	HIGH SPEED MASTER PU 10HP 230-460V 3PH 35 GALLON	1	--
2	5215834	AUTOSTACKER MPU 3ph ELECTRICAL BOX ASSEMBLY	1	A
3	5530304	HHB M8 x 1.25 x 20	4	--
4	5545341	WASHER M10 x Ø20 FLAT	4	--
5	5535001	NUT M8 x 1.25 NL	4	--
6	5905025	WARNING ELECTRICAL SHOCK LABEL	1	--
7	5905045	RISK OF FIRE LABEL	1	--
8	5905397	CONSOLE OPERATION LABEL	1	--
9	5906012	CONSOLE WARNING LABEL	1	--
10	5174028	MIE MASTER POWER UNIT PLUMBING KIT	1	B
11	5550004	FIG ELB 1/4 TUBE INS 3/8 NPT	1	--

DO NOT SCALE DRAWING

DIMENSIONS ARE IN MM

NAME: _____ DATE: _____
 DRAWN: TS 03/23/2018
 CHECKED: OR 07/23/2020

THIRD ANGLE PROJECTION

PROPRIETARY AND CONFIDENTIAL
 THE INFORMATION CONTAINED IN THIS DRAWING IS THE SOLE PROPERTY OF BENDPAK INC. ANY REPRODUCTION IN PART OR AS A WHOLE WITHOUT THE WRITTEN PERMISSION OF BENDPAK INC. IS PROHIBITED.

BendPak.
 1645 LEMONWOOD DR.
 SANTA PAULA, CA 93060

TITLE: AUTOSTACKER 3 PHASE MPU KIT

SIZE DWG. NO. REV
 A 5105210 B

SCALE: 1:12 SHEET 1 OF 1

CE Certificate

ZERTIFIKAT ◆ CERTIFICATE ◆ 認証証書 ◆ СЕРТИФИКАТ ◆ CERTIFICADO ◆ CERTIFICAT

CE 2019 CERTIFICATE OF COMPLIANCE

Company: BendPak Inc.
1645 Lemonwood Dr.
Santa Paula, CA 93060

Report No. Q30919A6S

Date: 9/09/2019

Summary

Test Model(s): A6S-OPT1, A6S-OPT2, A6S-OPT3, A6W-OPT1, A6W-OPT2, A6W-OPT3

Description: Mechanical parking lifts / vehicle stackers / scissors type.

After careful evaluation and testing of the above listed equipment model(s), all areas analyzed met or exceeded the below mentioned standard(s) for safe operation. The products identified above comply with the principal elements of the safety objectives of the Machinery Directive, Low Voltage Equipment Directive, and Electromagnetic Compatibility Directive and the manufacturer has applied the following standards.

Specific Referenced Standard(s) For Meeting Compliance Criteria:

EN14010	Parking Lift Standard
2006/42/EC	Machinery Directive
2006/95/EC	Low Voltage Directive
2004/108/EC	Electromagnetic Compatibility Directive
EN 60204-1:2006	Safety of machinery - Electrical equipment of machines - Part 1: General Requiriejments
EN 12100-1:2007	Safety of machinery - Basic concepts, general principles for design.

Other applicable standards partial or complete include, but not limited to: ANSI/ALI ALCTV-2006 Automotive Lifts - Safety Requirements for Construction, Testing, and Validation, CAN/CSA C22.2, ANSI/UL 201 American National Standard for Safety for Garage Equipment, Australian/New Zealand Standard AS/NZS 1418.9:1996, AWS D1.1 Structural Welding Code - Steel, ASTM A36/A36M-05 Standard Specification for Carbon Structural Steel, ASTM A618/A618M Standard Specification for Hot-Formed Welded and Seamless High-Strength Low-Alloy Structural Tubing, NF (CFR Reference) Standard Specification for Hot-Formed Welded and Seamless Carbon Steel Structural Tubing and SAE AMS 5080J Steel, Bars, Forgings, and Tubing, 0.31 0.38C (SAE 1035)

I hereby declare that the equipment named above has been designed to comply with the relevant sections of the above referenced specifications and essential requirements of the directives.

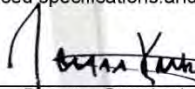

Director, Standards Body





1645 Lemonwood Drive
Santa Paula, CA 93060 USA