



Original

Installation And Service Manual

DIRECT-DRIVED TWO POST LIFT

Model: DP10

Cargo Claims

If there is any missing or damaged product during transportation, the buyer must not sign on the shipping paperwork or refuse the shipment. NOTATE ALL DAMAGE OR REFUSE DAMAGED SHIPMENT!



DANGER

Read the entire contents of this manual before using this product. Failure to follow instructions and safety precautions could result in serious injury or even death. Make sure all other operators also read this manual. Keep this manual near the machine so that it can be seen by all users. By proceeding with installation and operation, you agree that you are fully understand the contents of this manual and take full responsibility for the use of the product.

CONTENTS

PROFILE	1
OWNER/EMPLOYER RESPONSIBILITIES	2
IMPORTANT SAFETY INSTRUCTIONS	3
SAFETY WARNING LABEL	5
I. PRODUCT FEATURES AND SPECIFICATIONS	6
II. INSTALLATION REQUIREMENT	9
III. INSTALLATION STEPS	11
IV. EXPLODED VIEW	32
V. TEST RUN	38
VI. OPERATION INSTRUCTIONS	40
VII. MAINTENANCE SCHEDULE	43
VIII. TROUBLE SHOOTING	45
IX. CAR LIFT SAFETY TIPS	46
X. LIFT DISPOSAL	47

Explanation of the safety warning symbols used in this manual

-  **DANGER** Risk of death or injury
-  **WARNING** Dangerous or unsafe practices that may result in death or injury
-  **CAUTION** Dangerous or unsafe practices that may result in personal injury, product damage or property damage
- ATTENTION** Conditions that may result in damage to products or property

PROFILE

The two post lift is a commonly used vehicle repair and maintenance tool that uses a pneumatic hydraulic or electric system that can lift the car up to a certain height so that the vehicle can be placed in a suitable position for inspection and repair. Car lifts can be divided into pneumatic and electric. Modern car lifts are simple structure that should be safe, reliable, and easy to install.

This instruction manual is specially prepared for you. Your new lift is the product of over a decade of continuous research, testing and development. PEAK lifts are one of the best lifts you can purchase!

Please make sure to read through this manual before operating the lift.

Record the information on the nameplate label here:

Model No.: _____

Serial No.: _____

Manufacturer date: _____

WARRANTY

The warranty period for the steel structure part of new car lift is 5 years, hydraulic components, bronze bushings, sliders and plastic parts are under warranty for 3 years, and electrical components and cable warranty for 2 years. Rubber pads are without warranty. During the warranty period, the manufacturer will repair or replace the defective parts free of charge including shipping costs.

This warranty does not cover damage caused by normal wear and tear, improper use, damage in transit, or damage caused by lack of maintenance.

This warranty is unique and supersedes what is expressed and implied in all other warranties. The manufacturer shall not be liable for any particular, indirect or accidental

damage resulting in breach of or delay in the execution of the warranty. The manufacturer reserves the right to design and improve the product and has no obligation to make notice of the changes in advance.

The product warranty based on the above clause is based on the model number and serial number of the equipment. This information must be provided in conjunction with all warranty information at the time of service and warranty.

OWNER/EMPLOYER RESPONSIBILITIES

Deliver the lift specific, operation, inspection, and maintenance instructions to lift owner/user/employer along with the other instructional materials furnished with the lift.

1. The owner/employer shall ensure that the lift operators are qualified and trained in accordance with the manufacturer's operating instructions to safely operate and use the lift; ALI/SM10-1, ALI Lifting it Right Safety Manual; ALI/ST-10 ALI Safety Tips Card; ANSI/ALI ALOIM-2008(R2013), American National Standard for Automatic Lifts - Safety Requirements for Operation, Inspection and Maintenance; ALI/WL101 Series, ALI Uniform Warning Label Decals/Placards; and in the case of frame engaging lifts, ALI/LP-GUIDE, Vehicle Lifting Points/Quick Reference Guide for Frame Engaging Lifts.
2. The Owner/Employer shall establish procedures to periodically inspect the lift in accordance with the lift manufacturer's instructions or ANSI/ALI ALOIM-2008 (R2013), American National Standard for Automotive Lifts - Safety Requirements for Operation, Inspection and Maintenance; and the Employer shall ensure that the lift inspectors are qualified and that they are adequately trained in the inspection of the lift.
3. The Owner/Employer shall establish procedures to periodically maintain the lift in accordance with the lift manufacturer's instructions or ANSI/ALI ALOIM-2008 (R2013), American National Standard for Automotive Lifts - Safety Requirements for Operation, Inspection and Maintenance; and the Employer shall ensure that the lift service personnel are qualified and that they are adequately trained in the maintenance of the lift.
4. The Owner/Employer shall maintain the periodic inspection and maintenance records recommended by the lift manufacturer's instructions or ANSI/ALI ALOIM-2008

(R2013), American National Standard for Automotive Lifts - Safety Requirements for Operation, Inspection and Maintenance.

5. The Owner/Employer shall display the lift manufacturer's operating instructions; ALI/SM 10-1, ALI Lifting it Right safety manual; ALI/ST-10 ALI Safety Tips card; ANSI/ALI ALOIM-2008 (R2013), American National Standard for Automotive Lifts - Safety Requirements for Operation, Inspection and Maintenance; ALI/WL Series, ALI Uniform Warning Label Decals/Placards; and in the case of frame engaging lifts, ALI/LP- GUIDE, Vehicle Lifting Points/Quick Reference Guide for Frame Engaging Lifts in a conspicuous location in the lift area convenient to the operator.
6. The Owner/Operator shall provide necessary lockout/tag out means for energy sources per ANSI Z244.1-1982 (R1993), Safety Requirements for the Lockout / Tag out of Energy Sources, before beginning any lift repairs and maintenance.
7. The Owner/Employer shall not modify the lift in any manner without the prior written consent of the manufacturer.

 **WARNING** If the lift is not functioning properly, please adjust or repair it by **trained lift service personnel** before use.

 **WARNING** The troubleshooting and maintenance procedures described in this manual can be completed by the owner/employer of the lift. Any additional repairs or failures should only be performed by **trained lift service personnel**.

IMPORTANT SAFETY INSTRUCTION

In order to properly maintain your product and ensure operator safety, it is the responsibility of the product owner to read and follow these instructions!

1. Ensure product installation complies with all applicable local, state and federal codes, regulations and rules, such as state and federal OSHA regulations and electrical codes.
2. Ensure that all operators are properly trained, know how to operate the unit safely, and are properly supervised.
3. Do not operate the lift until you are sure all parts are in place and operating correctly.
4. Keep your hands and feet away from the machine. Keep hands and feet away from any moving parts. Keep your feet away from the lift as it descends to avoid pressing on pointed objects.





5. Keep the work area clean. A cluttered workspace can lead to injuries.
6. The machine is only approved for indoor installation and use. Outdoor installation is prohibited.
7. Only trained operators are allowed to handle the lift machine. All untrained persons must stay away from the workplace. Never allow untrained persons to handle or operate the machine.
8. Use the lift properly. Use the lift in the correct way.
9. Warning! Keep persons and objects from under the lift when lifting a vehicle.
10. If the vehicle is at risk of falling, make sure no one is around the lift.
11. Before preparing to approach or service the vehicle, ensure that the safety device is in effect.
12. Dress appropriately when operating machines, and consider wearing non-slip steel-toe shoes for added safety..
13. Beware of electric shock. In order to protect the operator from electric shock, the lift in use must be grounded. Do not connect the green wire to the terminal. This is the ground wire.
14. Danger! The power supply used in this type of lift has high voltage. Please disconnect the power supply before any circuit repair. Unplug in case the power supply is accidentally switched on during maintenance.
15. Warning! There is a risk of explosion. There are parts in the equipment that produce arc light and spark. Do not operate near flammable gas. This machine should not be placed in the lounge or basement.
16. Maintain with care. Keep the machine clean for better and safer operation. Perform proper lubrication and maintenance procedures according to the manual. Keep handles or buttons clean, dry, and free of oil.
17. Stay alert. Use common sense to observe what you are doing and stay alert.
18. Check for damaged parts. Check for adjustments to moving parts, damage to parts, or anything that may affect their operation. Do not use the machine if the parts are damaged.
19. Do not remove relevant safety parts from the machine. Do not use a lift if it is damaged or missing.
20. Operate the lift only temperature from 41°F to 104°F (50°C to 40°C).

For additional safety instructions regarding lifting, lift types, warning labels, preparing to lift, vehicle spotting, vehicle lifting, maintaining load stability, emergency procedures, vehicle lowering, lift limitations, lift maintenance, good shop practices, installation,

operator training and owner/employer responsibilities, please refer to "Lifting It Right" (ALI/SM) and "Safety Tips" (ALI/ST) and vehicle lift points for service garage lifting SAE J2184.

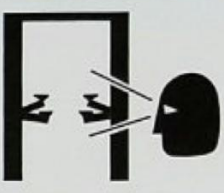
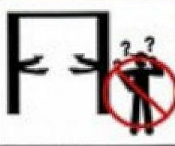
Refer to ANSI/ALI ALIS, Safety Requirements for Installation and Service of Automotive Lifts for additional information.

SAFETY WARNING LABEL

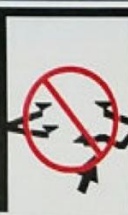
<p>NOTICE</p>  <p>Read operating and safety manuals before using lift.</p>	<p>NOTICE</p>  <p>Proper maintenance and inspection is necessary for safe operation.</p>	<p>CAUTION</p>  <p>Lift to be used by trained operator only.</p>	<p>CAUTION</p>  <p>Authorized personnel only in lift area.</p>	<p>WARNING</p>  <p>Clear area if vehicle is in danger of falling.</p>	<p>WARNING</p>  <p>Position vehicle with center of gravity midway between adapters.</p>
<p>NOTICE</p>  <p>Do not operate a damaged lift.</p>	<p>The messages and pictographs shown are generic in nature and are meant to generally represent hazards common to all automotive lifts regardless of specific style.</p> <p>Funding for the development and validation of these labels was provided by the Automotive Lift Institute, PO Box 85 Cortland, NY 13045.</p> <p>Replacement label sets may be obtained from the original lift manufacturer and ALI's member companies. They are protected by copyright.</p> <p>www.autolift.org © 2006-2016 ALI, Inc. ALI/WL101w</p>				
<p>The messages and pictographs shown are generic in nature and are meant to generally represent hazards common to all automotive lifts regardless of specific style.</p>					
<p>Funding for the development and validation of these labels was provided by the Automotive Lift Institute, PO Box 85 Cortland, NY 13045.</p>					
<p>Replacement label sets may be obtained from the original lift manufacturer and ALI's member companies. They are protected by copyright.</p>					
<p>www.autolift.org © 2011 by ALI, Inc. ALI/WLSIA01</p>					

The above safety WARNING labels used for lifts.

ATTENTION Some of the images in this manual are generic, and these images may differ from the lift you purchased. References: Automobile lift Research Institute.

Fig.1



Fig. 2

I. PRODUCT FEATURES AND SPECIFICATIONS

CLEAR-FLOOR DIRECT-DRIVE TWO POST LIFT FEATURES

Model DP10

- Direct-drive technology minimizes the lift wear on parts and decreases failure rate.
- Self-lubricating UHMW Polyethylene sliders and bronze bushings offer smooth operation..
- Single-point safety release offers easy lock disengaging.
- Clear-floor design, provides unobstructed floor use.
- Automatic overhead safety shut-off device.
- Standard stackable rubber pads.
- Adjustable heights accommodate varying ceiling heights.

SPECIFICATIONS

Model	Lifting Capacity	Lifting Time	Max Lifting Height		Max safety lock height		Overall Height	Overall Width	Minimum Pad Height	Motor	Maximum operating hydraulic pressure
			Without extension adapter	Include extension adapter	Without extension adapter	Include extension adapter					
DP10	10,000lbs (4500kg)	56S	71-1/2" (1815mm)	80-18/32" (2044mm)	69-1/2" (1765mm)	78-1/2" (1994mm)	142-1/2"/150-1/2" (3620/3823mm)	135" (3428mm)	3-1/2" (90mm)	2.0HP	2800psi

Arm Swings View

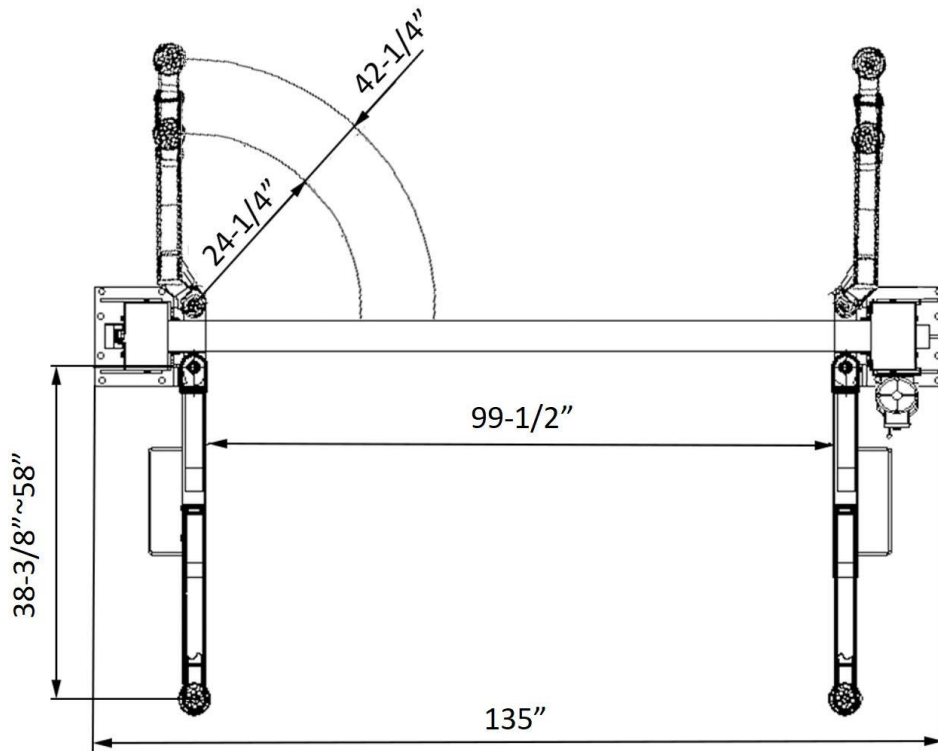

Fig.3

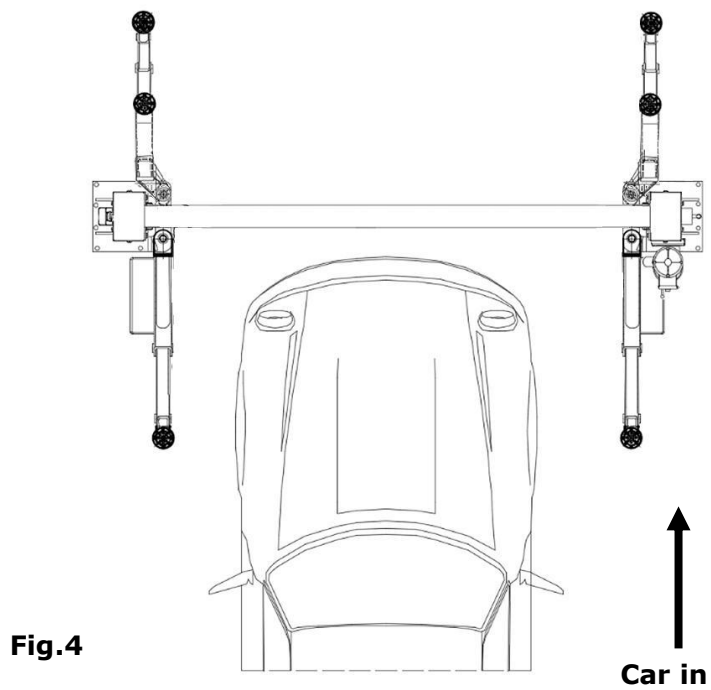

Fig.4

⚠ CAUTION When driving the vehicle, stay in the middle between the columns. If you hit any part of the lift, you could damage the car or lift.

ATTENTION Please identify the recommended location and shape of vehicle lift points refer "Vehicle lift points for service garage lifting SAE J2184" to determine the center of gravity position of the vehicle.

After the car passes, spread the arm to support the support point. Before lifting the vehicle, make sure it is neither front nor rear heavy. See image below. The center of gravity should be at the midpoint between each rubber pad.

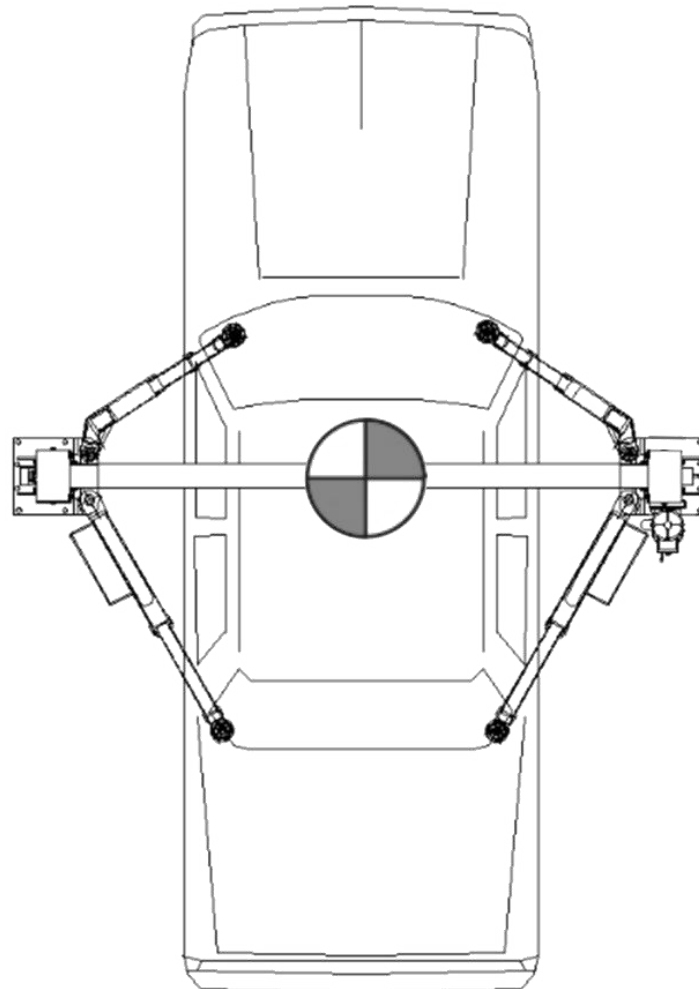

Fig.5

⚠ DANGER Read this manual carefully before using the product. Do not install or operate the product until you are familiar with all operating instructions and warnings. Do not allow anyone else to operate the product until they are also familiar with all operating instructions and warnings.

II. INSTALLATION REQUIREMENT

A. TOOLS REQUIRED

- ✓ Rotary Hammer Drill ($\Phi 19$)



- ✓ Hammer



- ✓ Level Bar



- ✓ English Spanner (12")



- ✓ Ratchet Spanner with Socket (28#)



- ✓ Wrench set

(8#, 10#, 13#, 14#, 17#, 19#, 24#)



- ✓ Carpenter's ink marker



- ✓ Screw Sets



- ✓ Tape Measure (7.5m)



- ✓ Pliers



- ✓ Socket Head Wrench (3#, 5#, 8#)



- ✓ Lock Wrench



Fig.6

B. Equipment storage and installation requirements.

1. Store the equipment in a dry, non-moldy, non-flammable environment.
2. The lift is generally approved for indoor installation and use. Outdoor installation is prohibited.
3. When installing the machine, take safety precautions according to the instructions to avoid device damage.
4. The equipment should not be installed outdoors if the installation area is not protected.
5. During installation, all parts should be fastened to ensure the stability and smooth operation of the machine.
6. After installation, the whole machine should be checked to make sure that every component is working properly

C. The equipment should be unloaded and transferred by forklift.

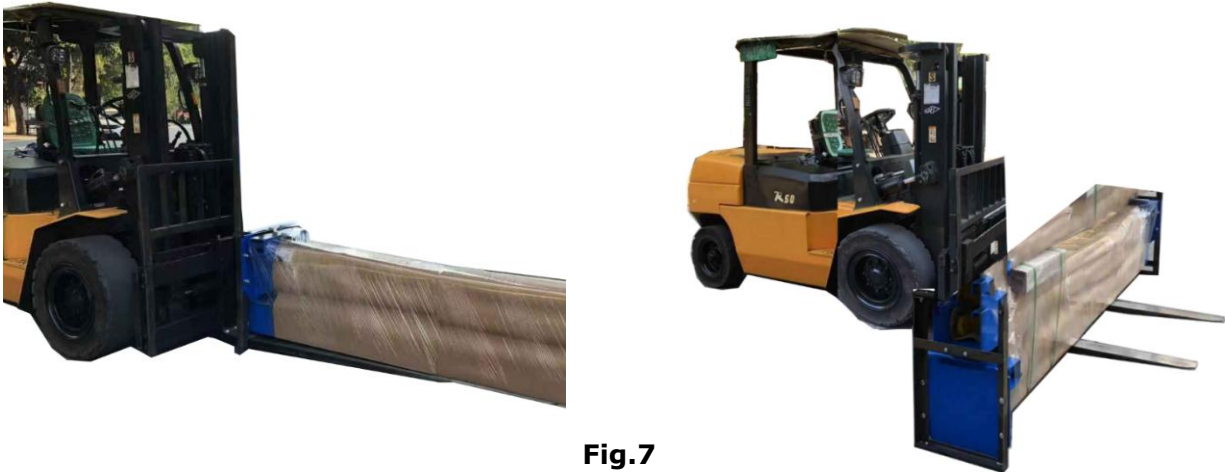

Fig.7

D. SPECIFICATIONS OF CONCRETE (See Fig. 8)

Specifications of concrete must be adhered to the specification as following.

Failure to do so may result in lift and/or vehicle falling.

1. Concrete must be thickness 4" minimum thick and without reinforcing steel bars, and must be dried completely before the installation.
2. Concrete must be in good condition and must be of test strength 3,000psi minimum. Solidify at least 15 days.
3. Floors must be level and contain no cracks.
4. Do not install the lift on asphalt or any surface other than concrete.

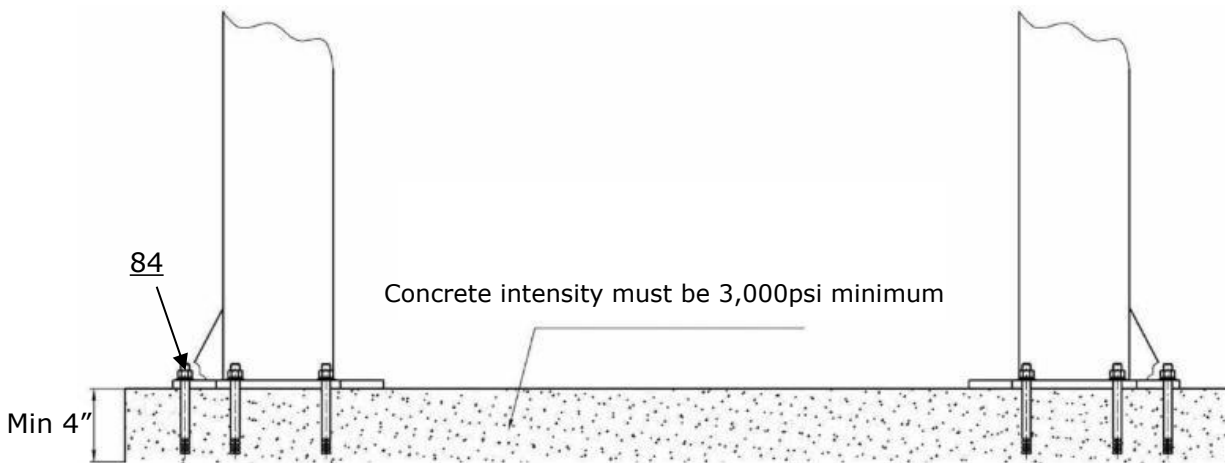

Fig. 8

E. POWER SUPPLY

1. You are required to use a licensed and qualified electrician for the installation process.
2. The power supply must be 220VAC/60Hz, current 20A, with a cord larger than 12AWG, and must be properly grounded.

⚠ DANGER All electrical wiring must be performed by a licensed and certified electrician. Attempting to connect the circuit without proper certification may result in damage to the lift or electrocution, resulting in serious injury or death.

III. STEPS OF INSTALLATION

A. Selecting the Location of Installation for DP10 should consider:

1. Architectural plans. Consult the architectural plans for your desired installation location. Make sure there are no contradictions between what you want to do and what the plans show.
2. Available space. Make sure there is enough space for the Lift; front, back, sides, and above. Refer to Specifications for specific measurements.(See Fig.9)
3. Overhead obstructions. Check for overhead obstructions such as building supports, heaters, lights, electrical lines, low ceilings, and so on.
4. Power. You need a 220 VAC, 60Hz, current 20A, with a cord larger than 12AWG.
5. Installations: PEAK car lifts are approved for indoor installation and use only. Outdoor installation is prohibited.

6. Floor. The lift should only be installed on a flat, level concrete surface and not on asphalt or any other type of flooring. It is important to ensure that surface not more than 3° slope before installation.

Workshop ceiling height larger than 151" can be installed high setting.

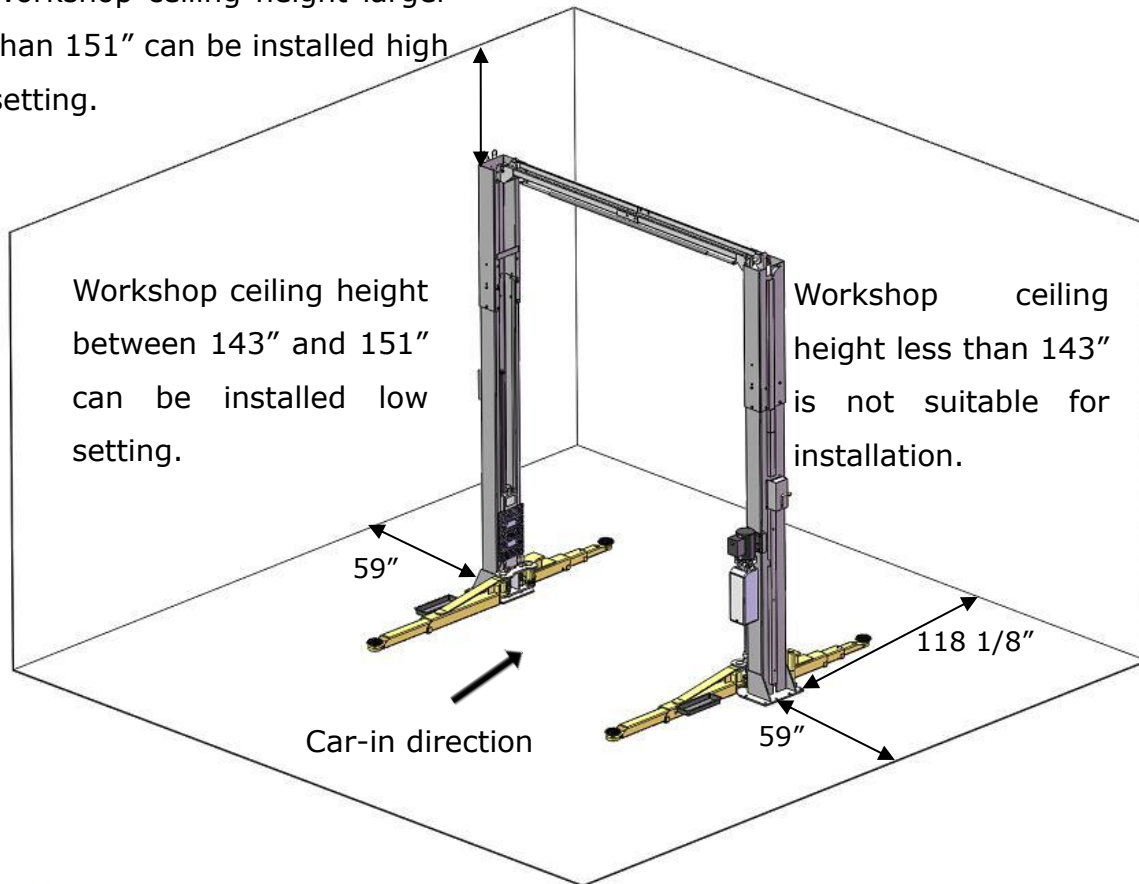

Fig.9

⚠ CAUTION Installing the lift on a surface with slopes more than 3° could lead to injury or even death. This lift is designed for installation on a flat and level surface only. (Defined as no more than 3/8 of an inch difference over the installation area). If the floor cannot be leveled, consider changing installation locations.

ATTENTION The PEAK lift installation and concrete construction must meet the latest version of the US national standard "Automotive Hoist-Safety Requirements for Construction, Testing and Verification", ANSI / ALI ALCTV. You are responsible for any special regional structure and/or seismic anchorage requirements specified by any other and/or code .(Such as the Uniform Building Code (UBC) and/or International Building Code (IBC).)

B. Use a carpenter’s ink marker line to establish installation layout of base-plate (See Fig.10).

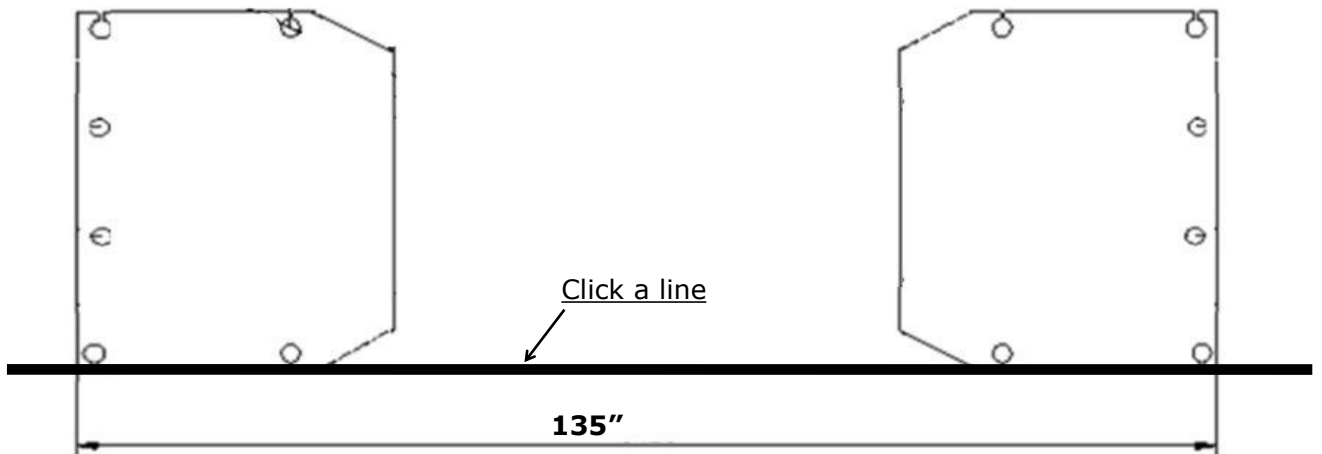

Fig.10

C. Check the parts before assembly.

1. Packaged lift and power unit (See Fig. 11).



Fig. 11

2. Move aside the lift with fork lift or crane, and open the package, take off the lifting arms and parts box to nearby installation site, check the parts according to the shipment parts list and inner package list (See Fig.12).

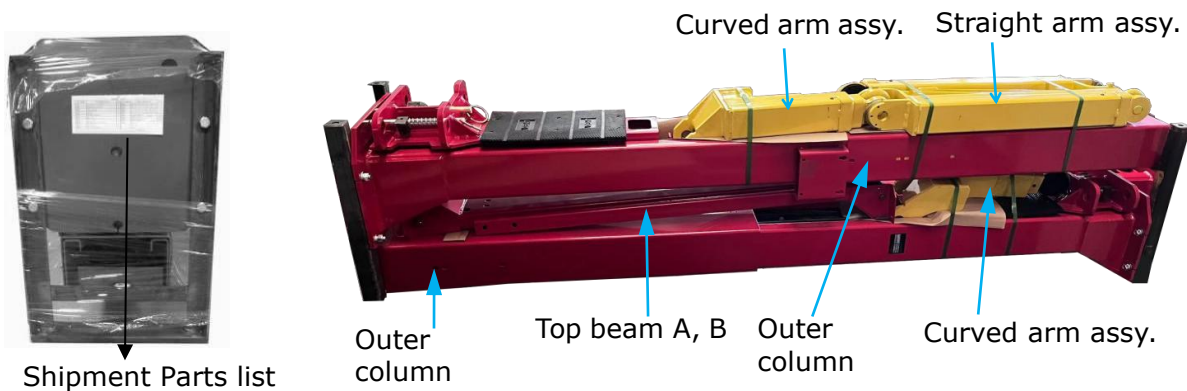
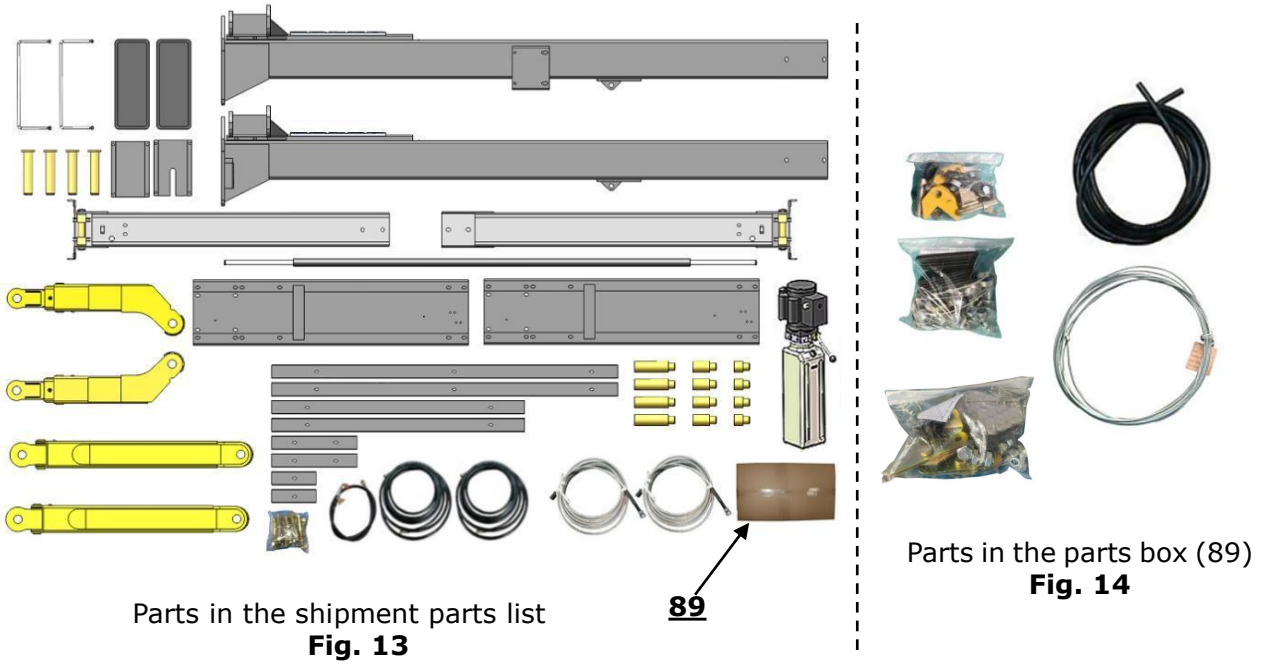

Fig.12

3. Loosen the screws of the upper package stand, take off the upper extension columns, take out the parts in the inner column and remove the package stand.

4. Move aside the parts and check the parts according to the shipment parts list.
 (See Fig.13 & 14).



5. Open the parts bag 1, 2 and 3; check the parts according to the list (See Fig. 15).

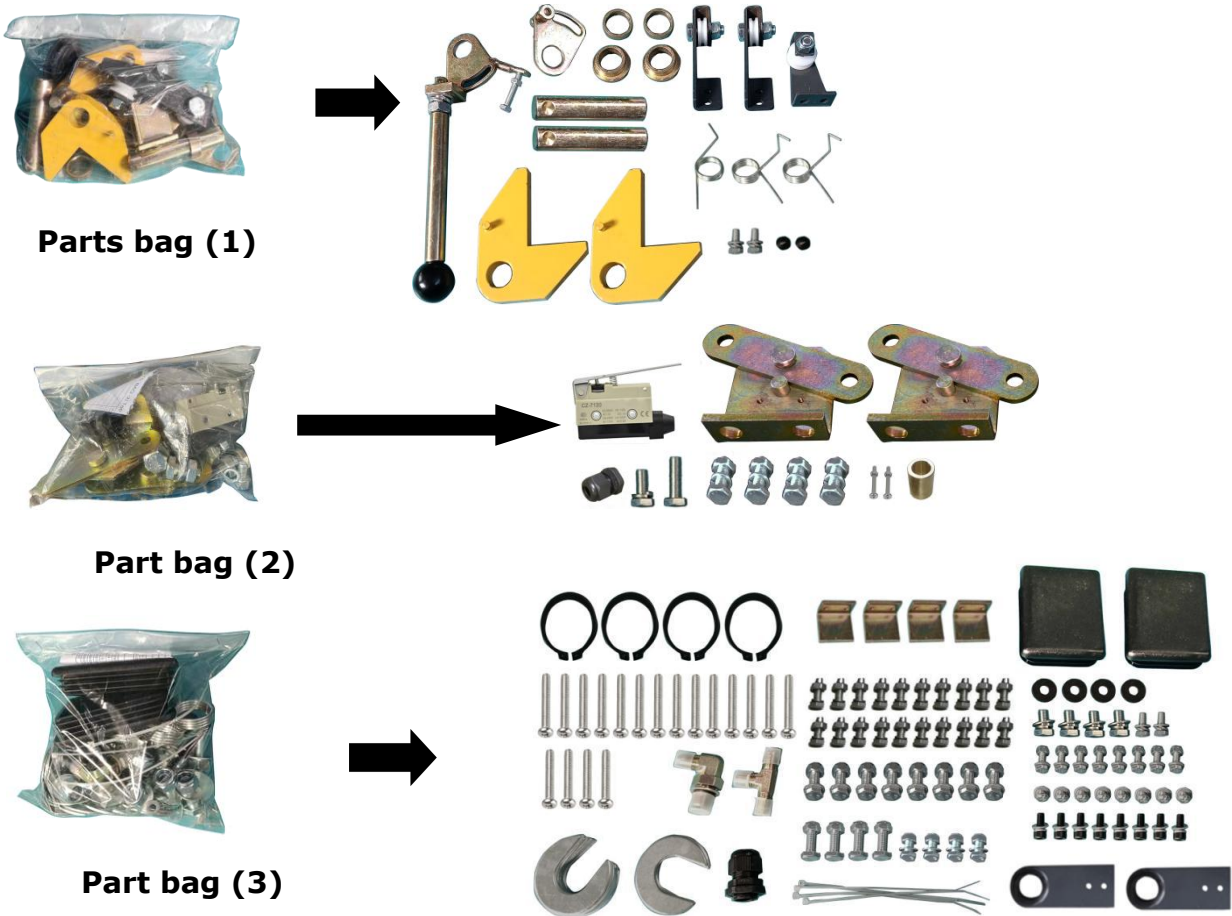

Fig. 15

D. Install parts of extension columns (See Fig. 16).

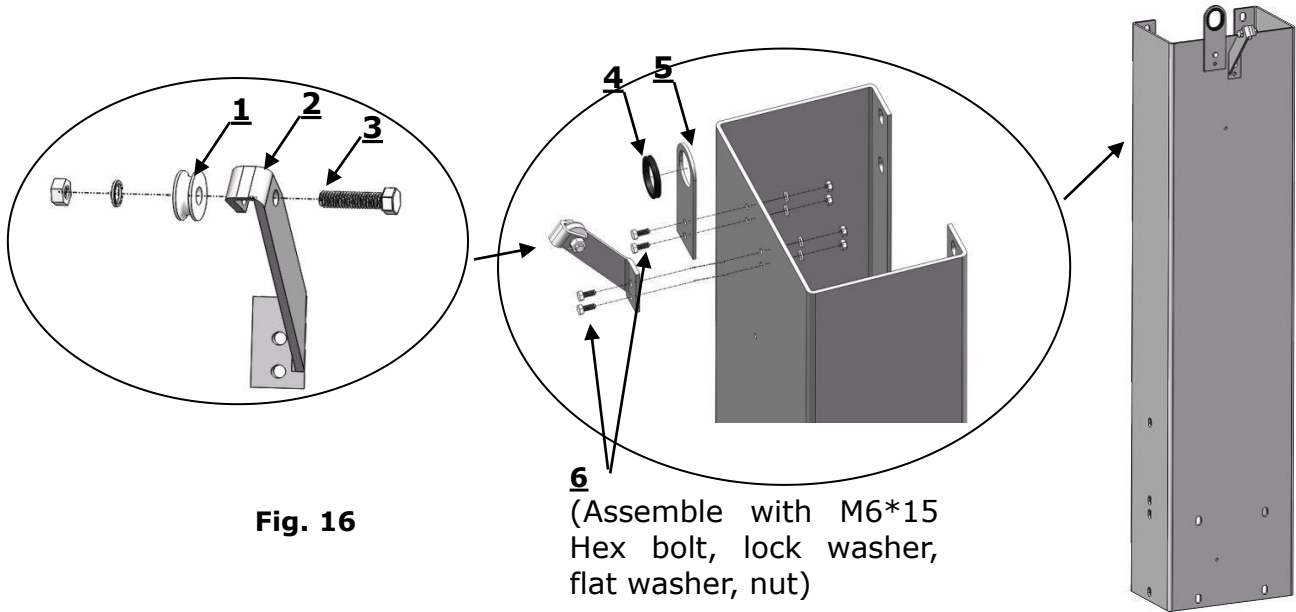

Fig. 16

6
(Assemble with M6*15 Hex bolt, lock washer, flat washer, nut)

E. Position columns

Place both columns laying down in installation site. Position the power-side column according to the actual installation site. Usually, it is suggested to install power-side column on the right-front side of vehicle entry direction which vehicles. This lift is designed with 2-Section columns. Adjust the height according to the ceiling height and connect the inner and outer columns.

NOTE:

The high setting is suitable for workshops with a ceiling height over 151”;

The low setting is suitable for workshops with a ceiling height between 143”-151”;

The lift is not suitable for workshops with a ceiling height less than 143”.

1. High Setting, connecting the lower holes of outer columns with inner columns (**See Fig. 17**).

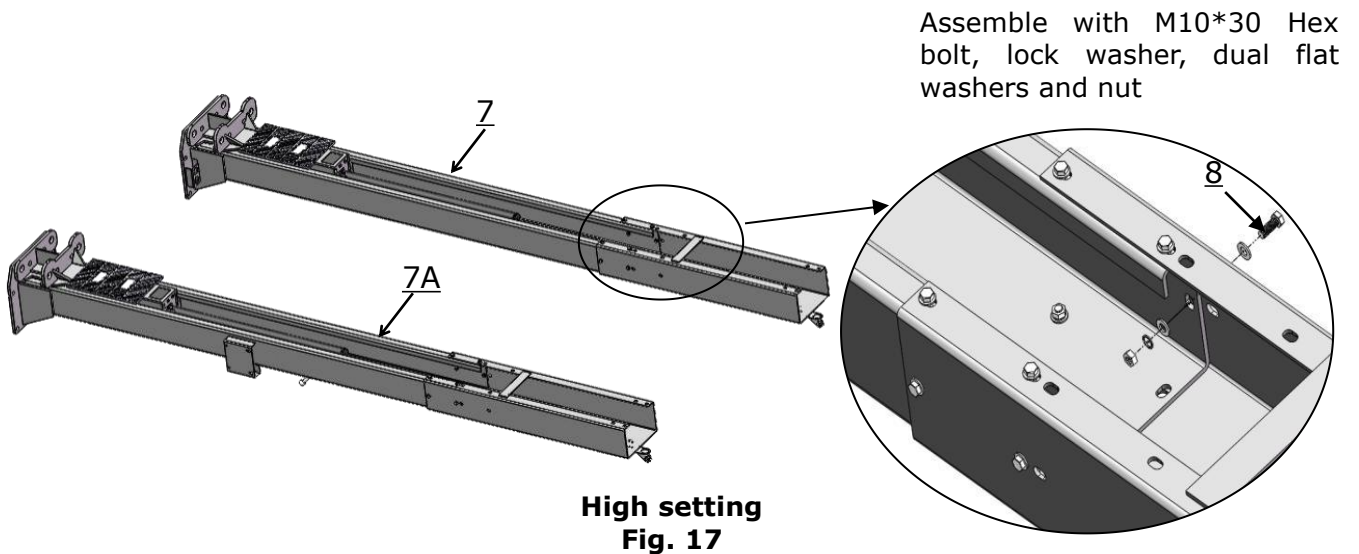

Assemble with M10*30 Hex bolt, lock washer, dual flat washers and nut

**High setting
Fig. 17**

2. Low Setting, connecting the upper holes of outer columns with inner columns (**See Fig. 18**).

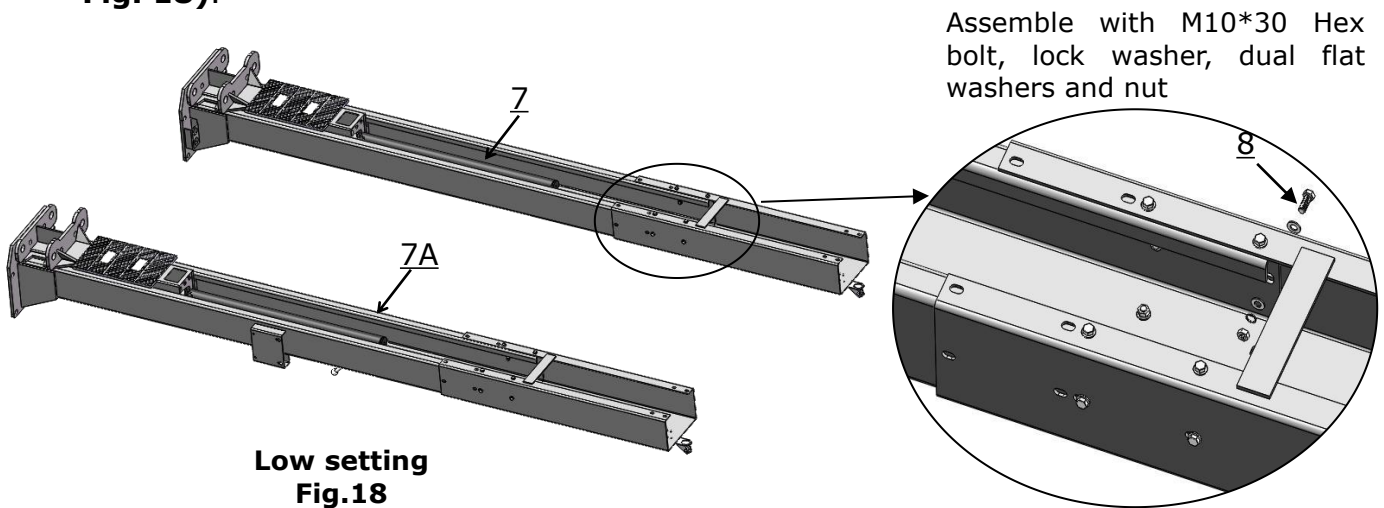

F. After fully assembling columns, install the anchor bolts. Check the Columns plumpness with level bar, and adjusting with the shims if the columns are not vertical. Do not tighten the Anchor Bolts.

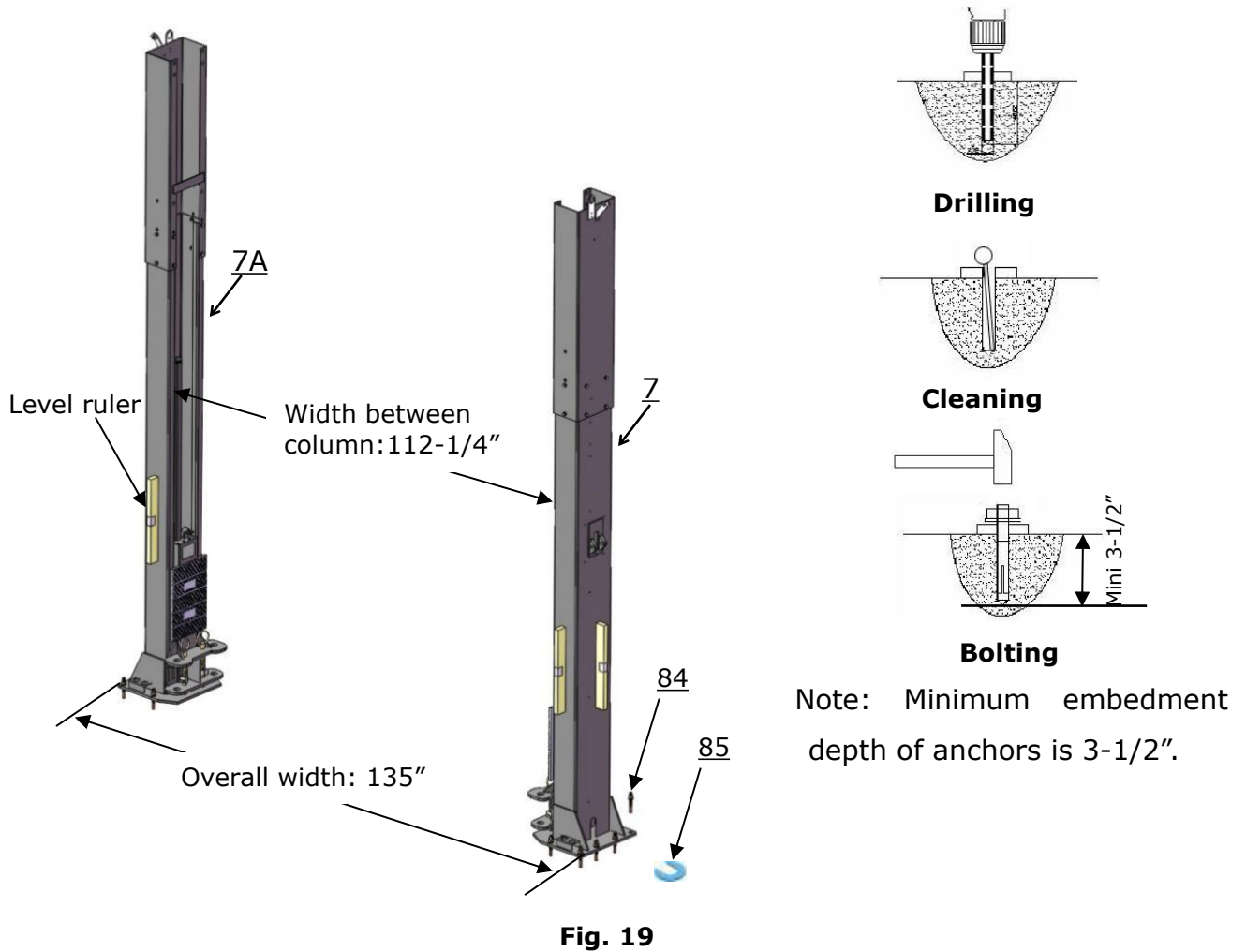

⚠ CAUTION Concrete and anchor bolts must comply with above specifications. Install lifts only on concrete surfaces. If you are in asphalt or either any other surface on which the lift is mounted, or the concrete or anchor bolts do not meet these specifications, it may result in product damage, vehicle damage, personal injury, or even loss of life.

The PEAK lift installation and concrete construction must meet the latest version of the US national standard "Automotive Hoist-Safety Requirements for Construction, Testing and Verification", ANSI / ALI ALCTV.

⚠ WARNING Use only the anchor bolts that came with your Lift. If you use components from a different manufacturer, you void your warranty and compromise the safety of everyone who installs or uses the Lift.

G. Install top beam

1. Hang the hook of top beam A on the outer column, then align the holes and install the bolts. **(See Fig. 20).**

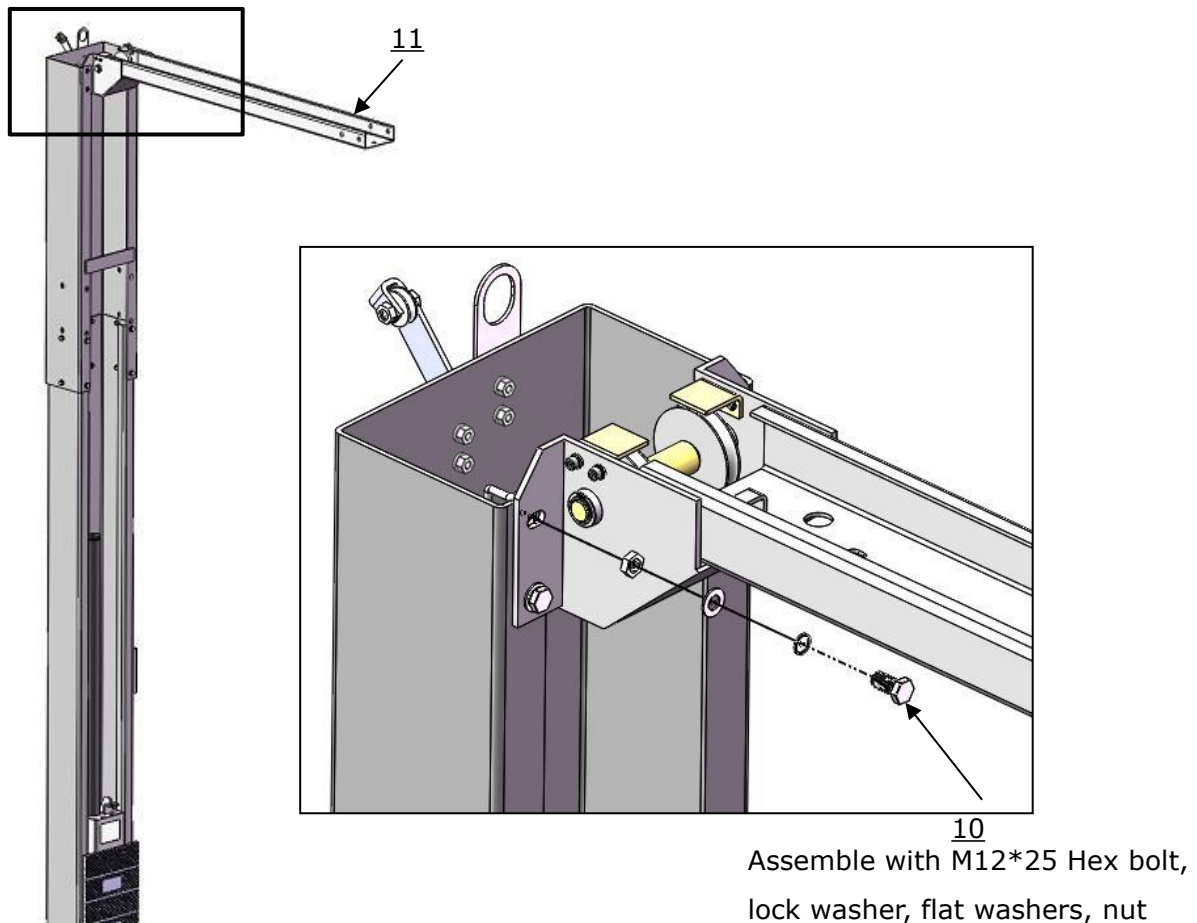

Fig. 20

2. Hang the hook of top beam B on the other outer column, and then bolted to top beam A. (See Fig. 21)

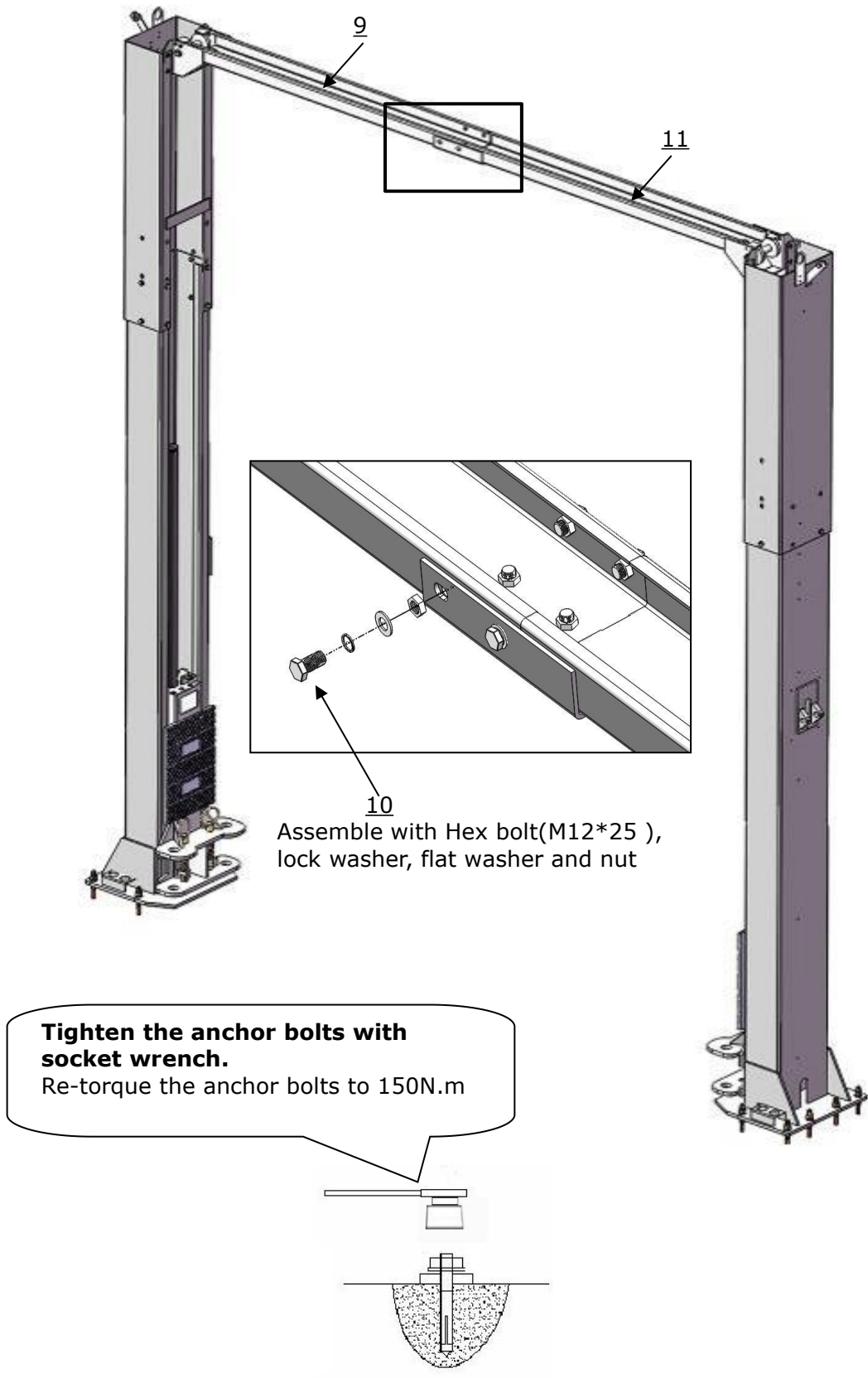
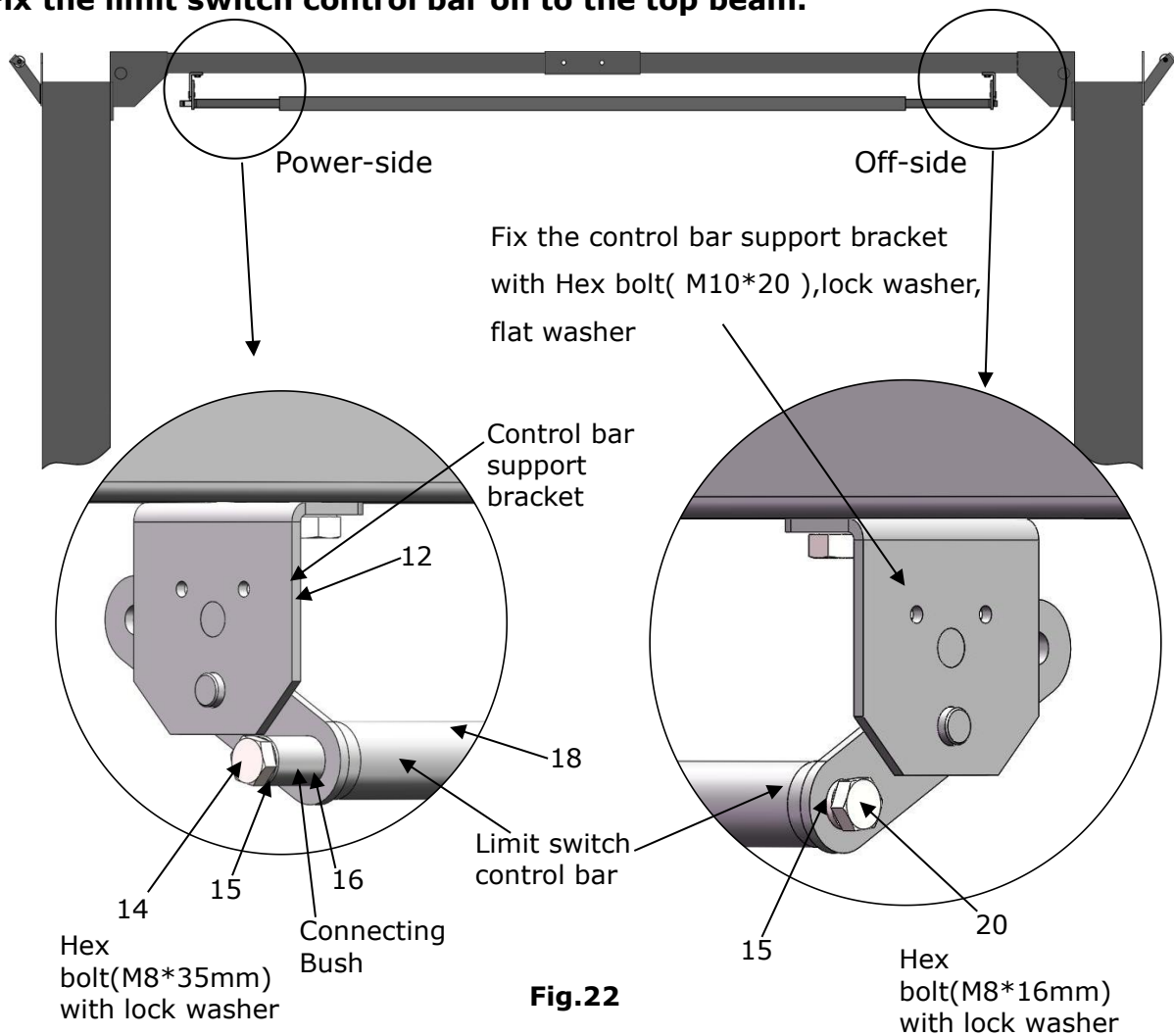

Fig. 21

H. Install the limit switch control bar and limit switch (See Fig. 22).

1. Fix the limit switch control bar on to the top beam.



2. Installing the limit assy.

Install the limit switch assy. to the power-side control bar support bracket as shown. Run the wire across the top beam hole and along the column to terminal box of the power unit.

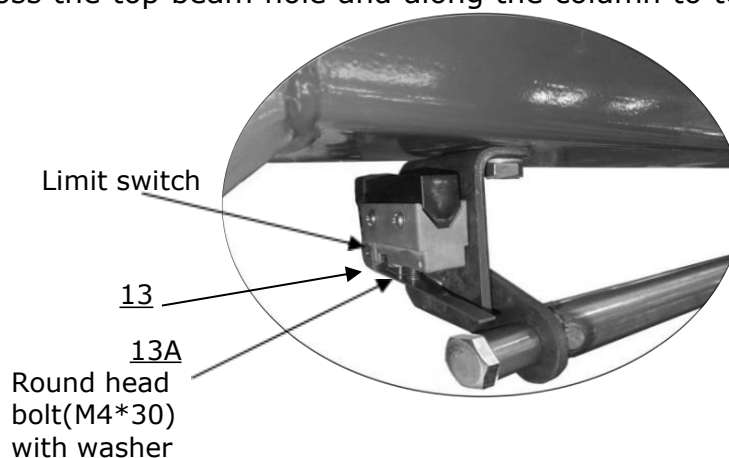

⚠ DANGER All wiring must be done by a licensed certified electrician. Do not perform any maintenance or installation of the lift without confirming that the main power had been disconnected from the lift and cannot be reactivated until all procedures have been completed.

I. Install safety device (See Fig. 24 & Fig. 25).

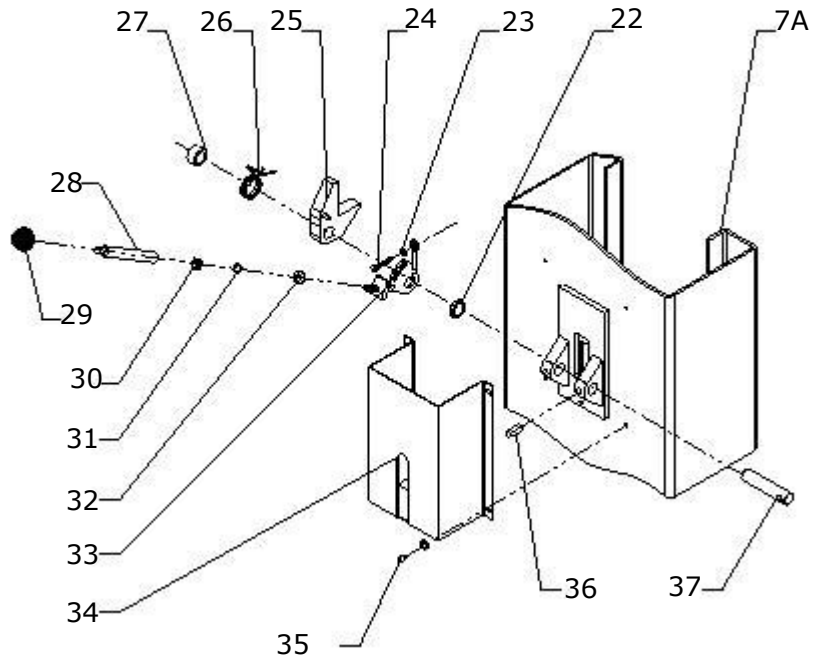
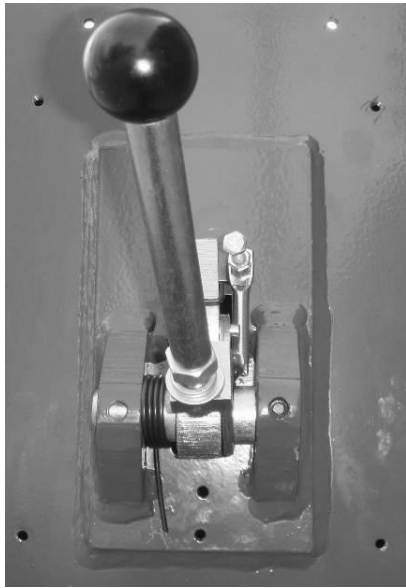

Power-side safety device

Fig.24

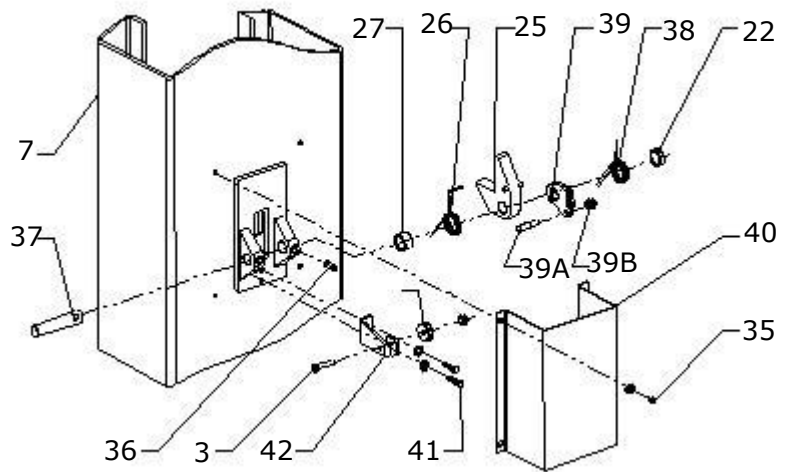

Offside safety device

Fig.25

⚠ DANGER Make sure the safety device is properly installed before using the lift.

J. Install cables

Lift the carriages up and lock them be locked at the same level.

1. Cable connection of low setting installation. (See Fig. 26).

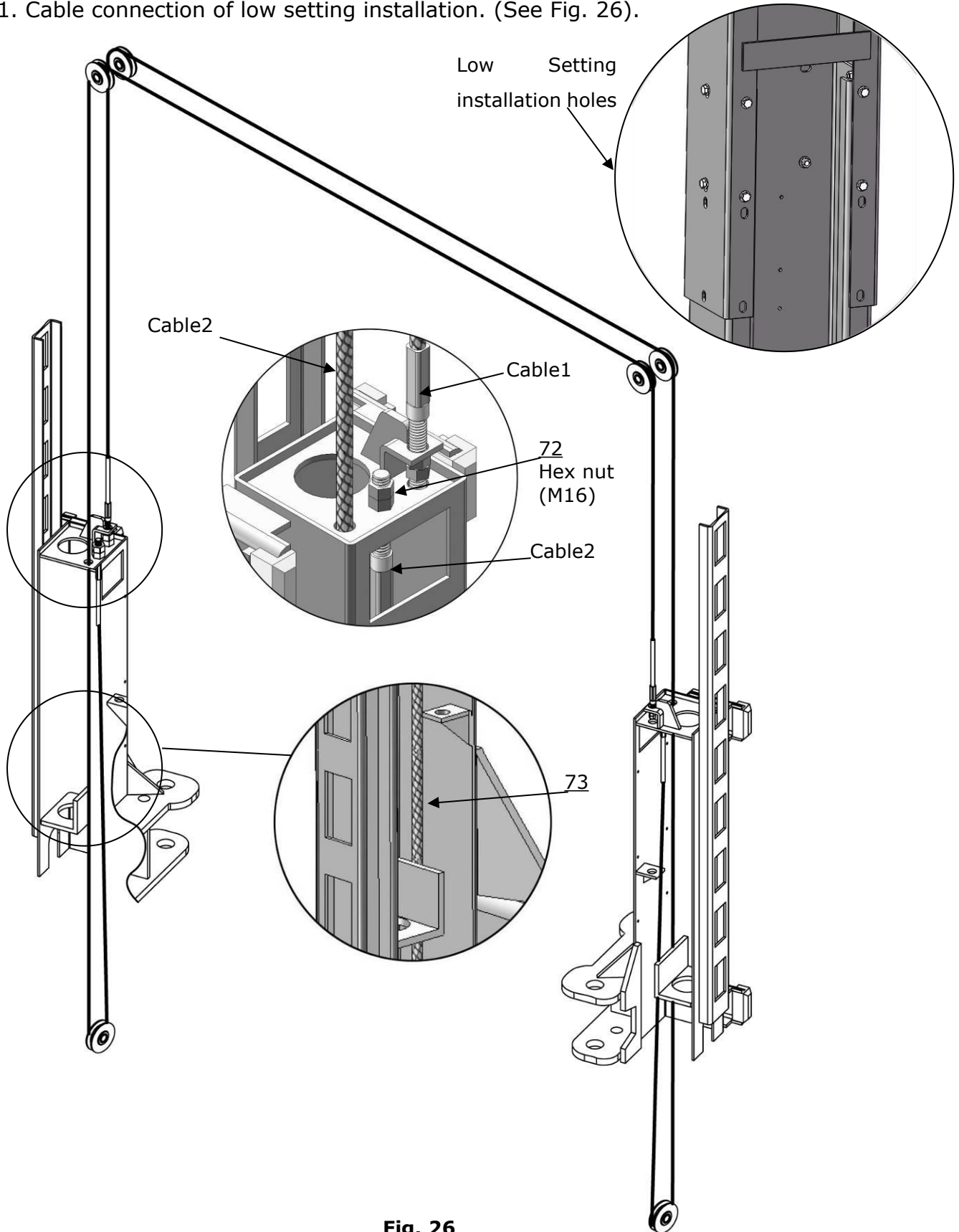

2. Cable connection of high setting installation.

2.1. Run the cable across from the bottom of the carriage and pull it out from the hole of carriage, then tighten two cable nuts. (See Fig. 27).

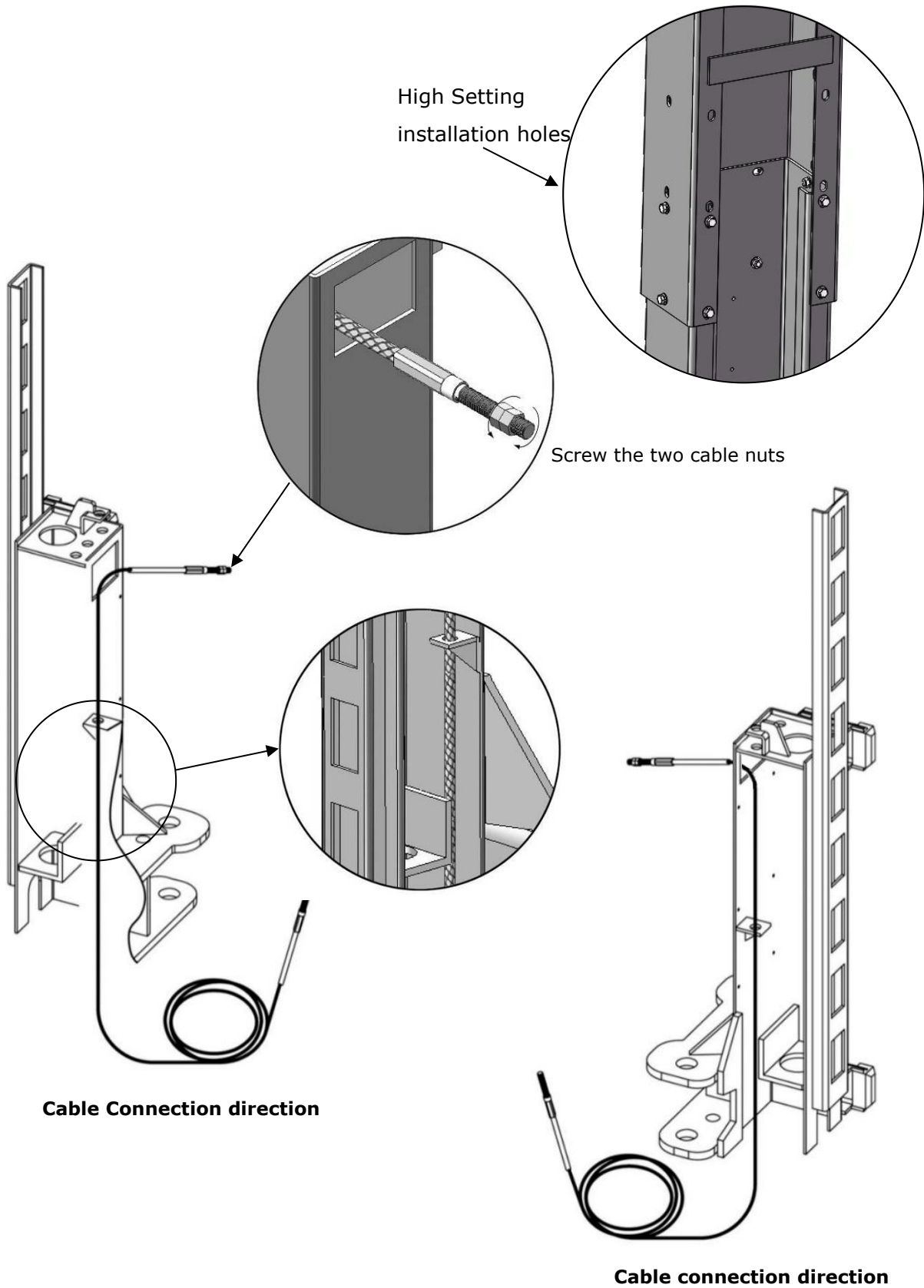

Fig. 27

2.2 Cable connection for high setting (See Fig. 28).

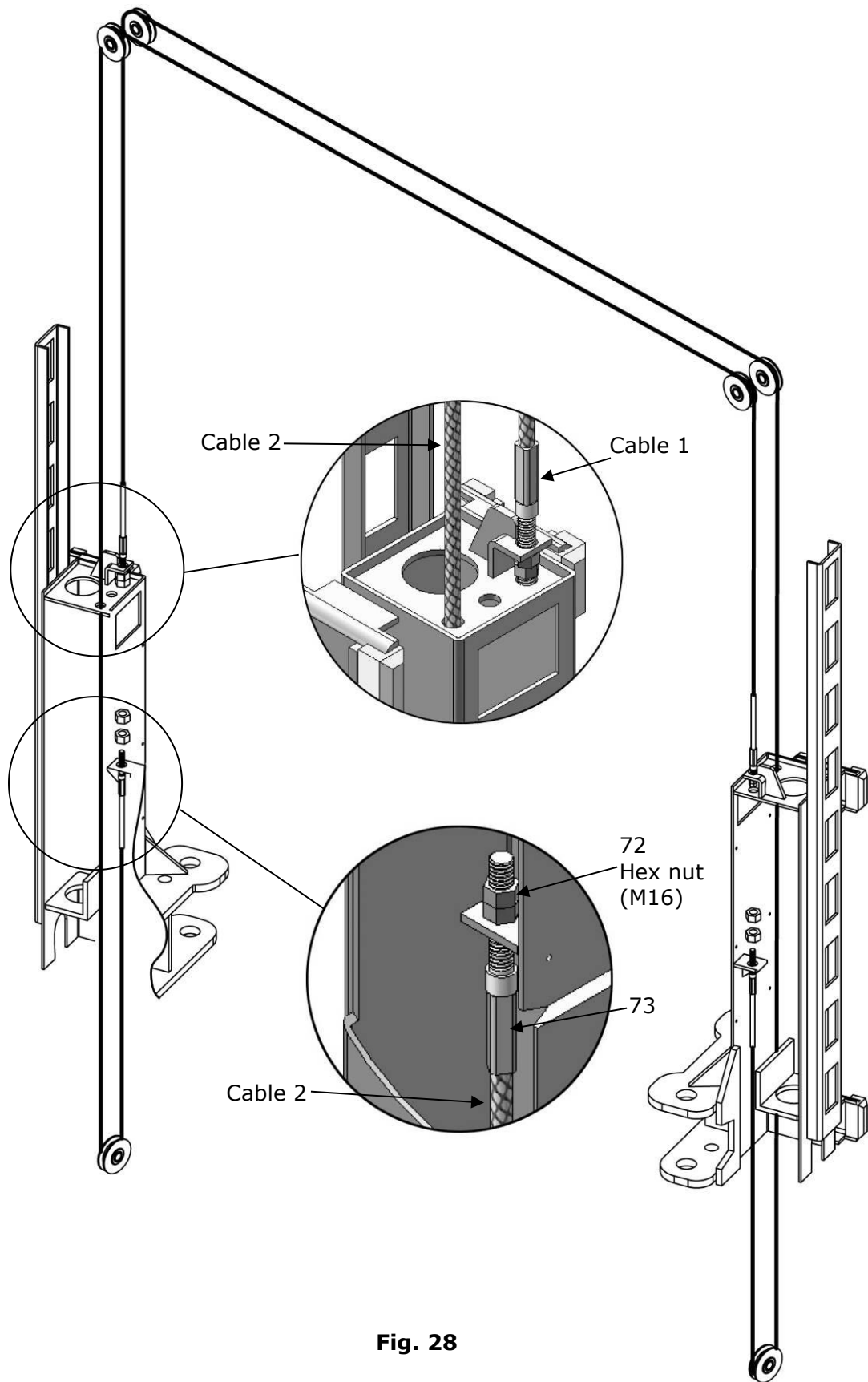

Fig. 28

K. Install power unit (See Fig. 29)

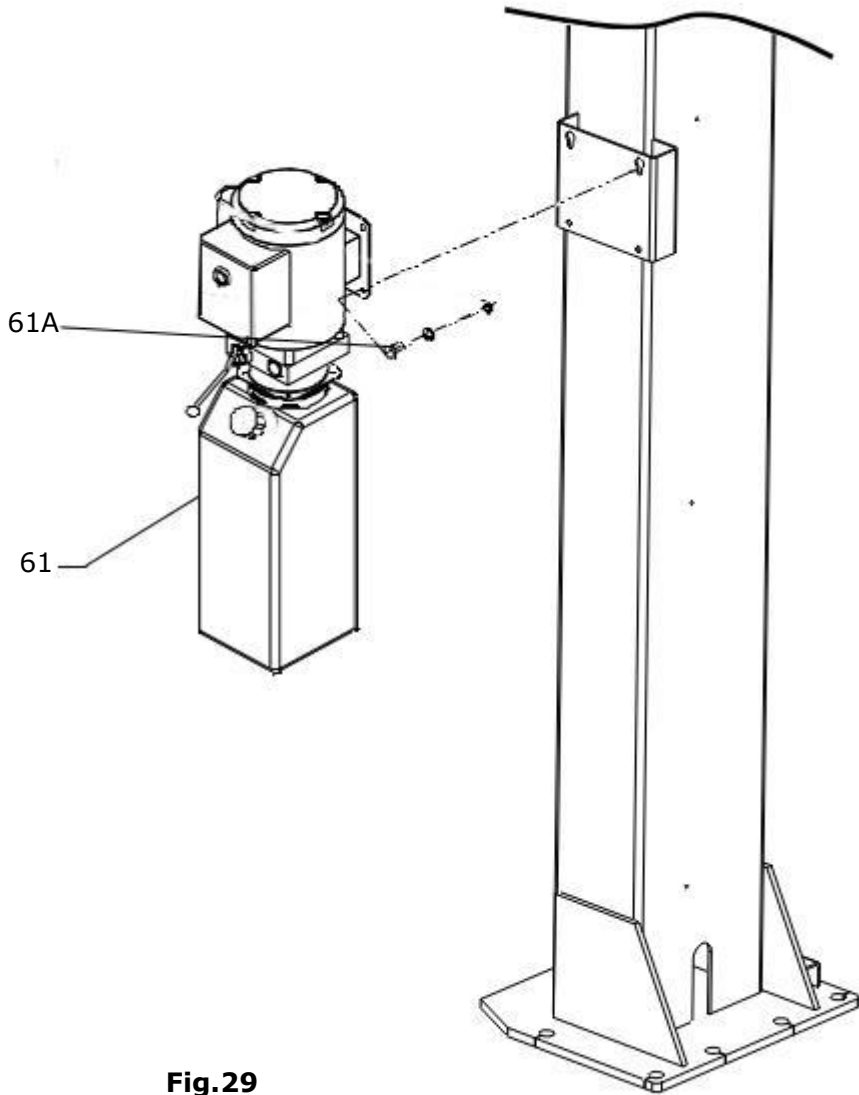

Fig.29

L. Install oil hose.

1. Connect 2 oil hoses as shown. (See Fig.30)

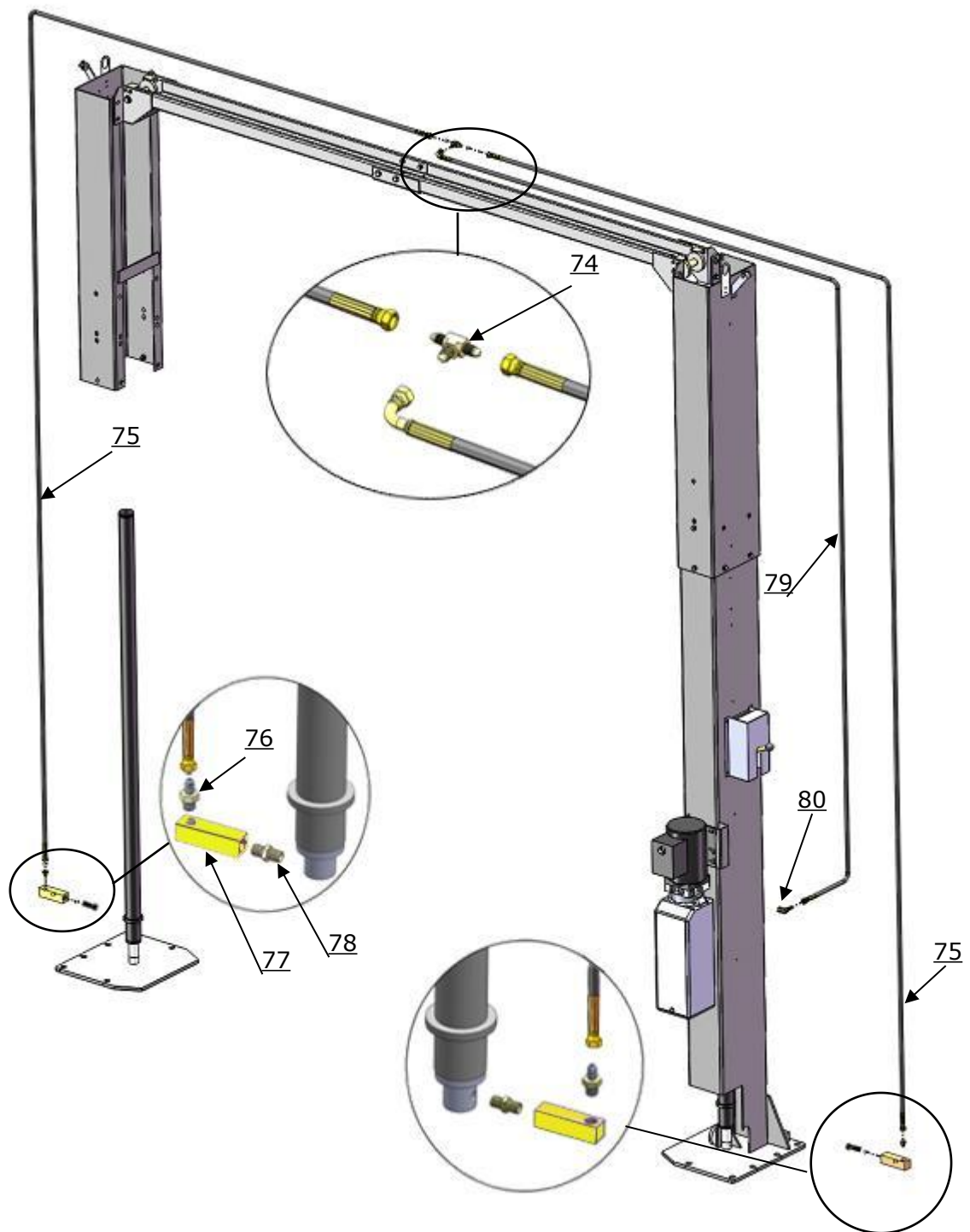
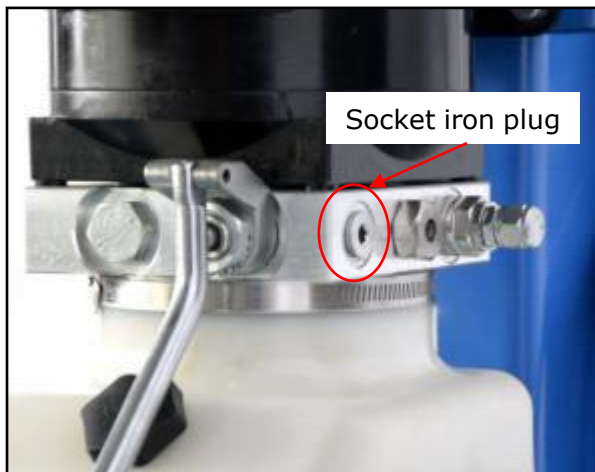
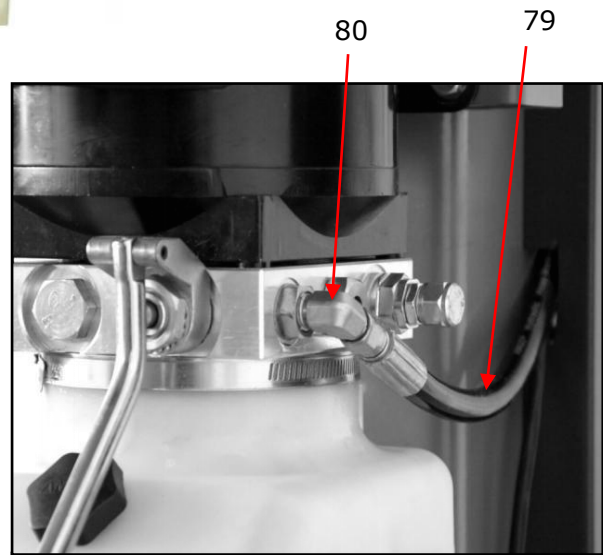

Fig.30

2. Follow these steps to connect the oil hose with power unit.



A. Remove the socket iron plug from the right oil outlet port.



B. Assemble 90° fitting to connect the power unit with oil hose.

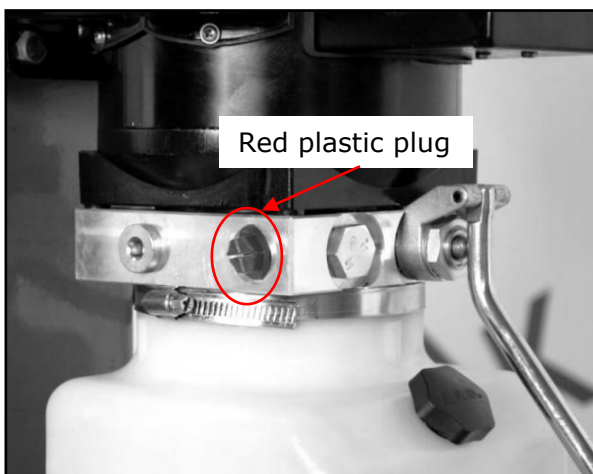

C. Remove the red plastic plug from the left oil outlet port.



D. Assemble the hex plug by Step A to this left oil inlet port.

Fig.31

M. Install protective cover. (Fig.32)

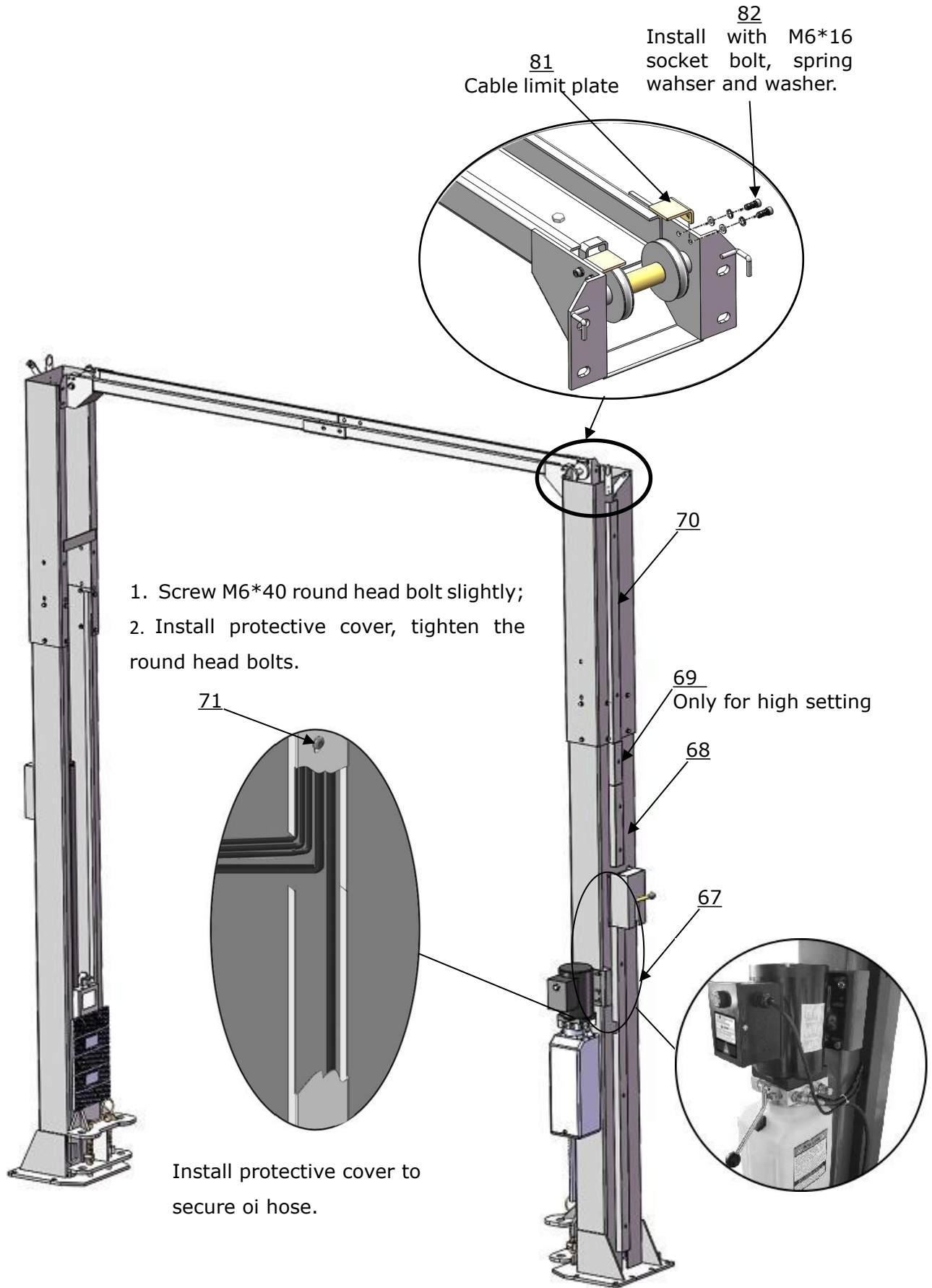

Fig.32

N. Install safety cable (See Fig. 33)

(Install safety cable. Start from off-side safety device, then pass it through the top beam, finally connect to power-side safety device.)

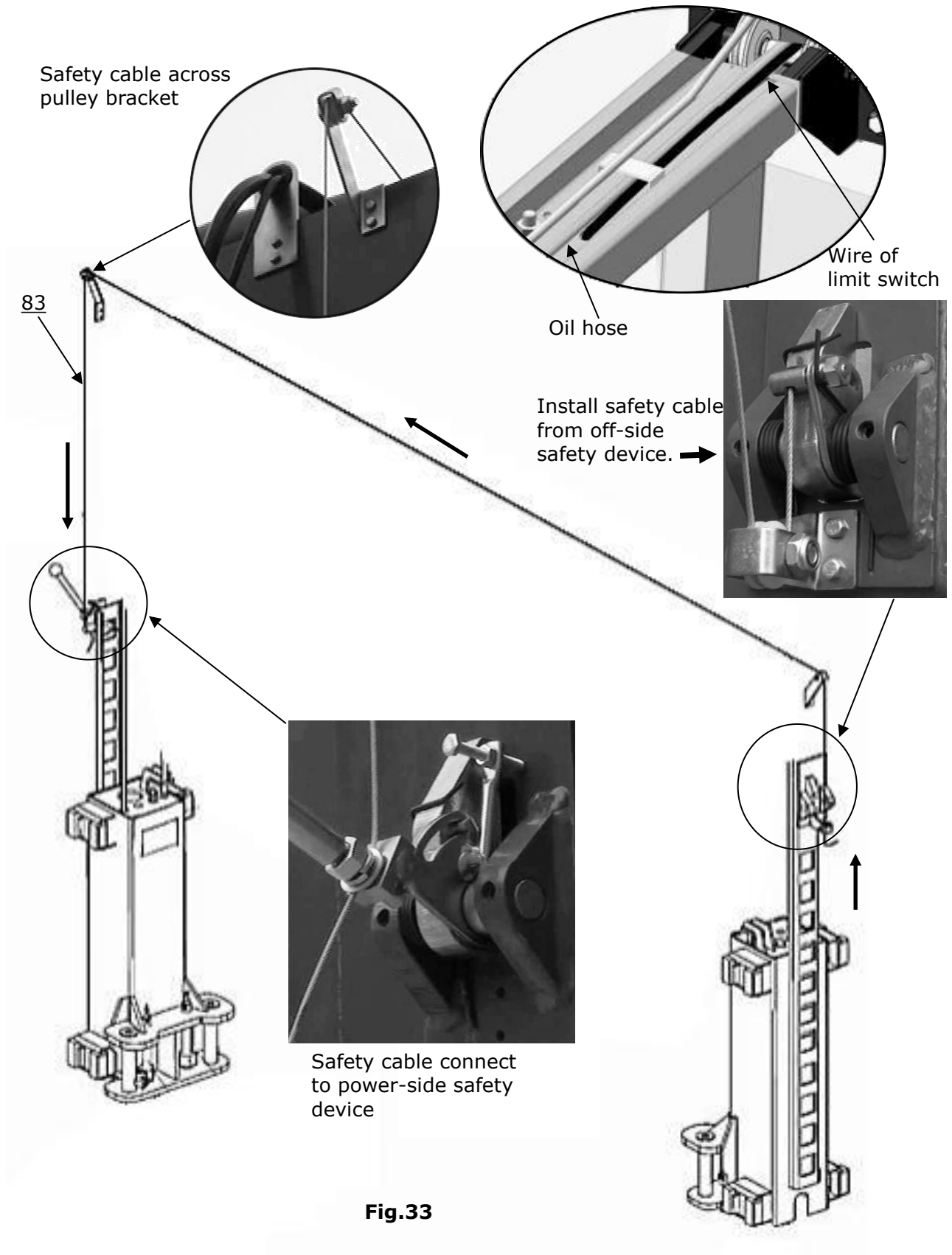

Fig.33

O. Install lifting arms, then install spring on the arm pin. Last install guard bar.

The process of engaging arm lock and moon gear:

Lowering the carriages down to the lowest position, then use the 8# socket head wrench to loosen the socket bolt (See Fig. 35); follow the arrow direction to adjust the moon gear (See Fig. 36); lock the bolts after the moon gear and arm lock are engaged well (See Fig. 37).

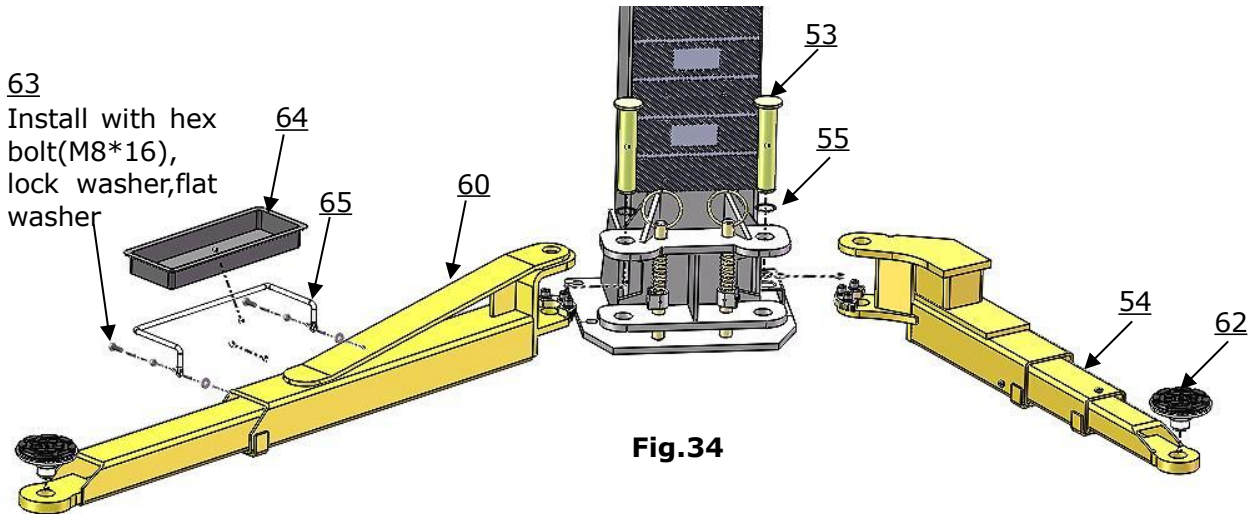
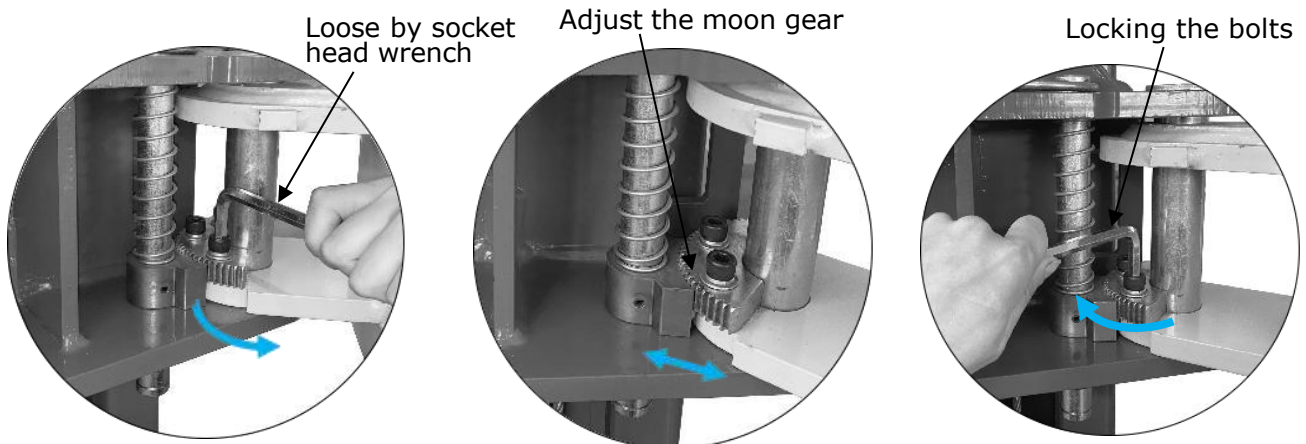

Fig.34

The process of engaging arm lock and moon gear



1. Use the 8# socket head wrench to loose the socket bolt

Fig.35

2. Follow the arrow direction to adjust the moon gear

Fig.36

3. Lock the bolts after the moon gear and arm lock are engaged well

Fig.37

⚠ DANGER Moon gear must be positioned and adjusted correctly. The lift should not be operated until the gears are fully engaged, and it is important to regularly check and adjust the arm restraint gears on all four arms. Failure to do so can result in vehicle damage, injury, or even death.

⚠ WARNING Each arm restraint assembly must be inspected and adjusted before you use the Lift each and every time. Do not operate the Lift if any of the four arm restraint systems are not functioning properly. Replace any broken components or components with broken teeth with authorized replacement parts only.

P. Tighten all the hydraulic fittings, fill the reservoir with hydraulic oil.

Note: In consideration of Hydraulic Power Unit's durability and keep the equipment running in the perfect condition, please use Hydraulic Oil 46#.

Q. Install electrical system

Connect the power source according to the nameplate of the motor.

Note:1. Install the limit switch.

2. For the safety of operators, the lift must connect with the ground wire.

Single phase motor wiring

1. The two live wires of the input power supply are respectively connected to the terminals marked L1 and L3 on the AC contactor.

Internal wiring diagram of limit switch: The cable has been connected.

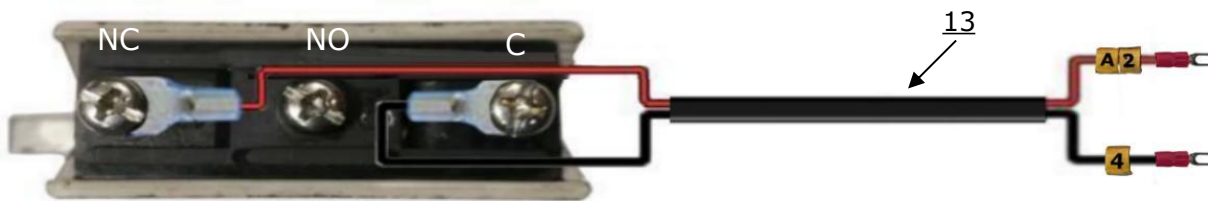

Fig.38

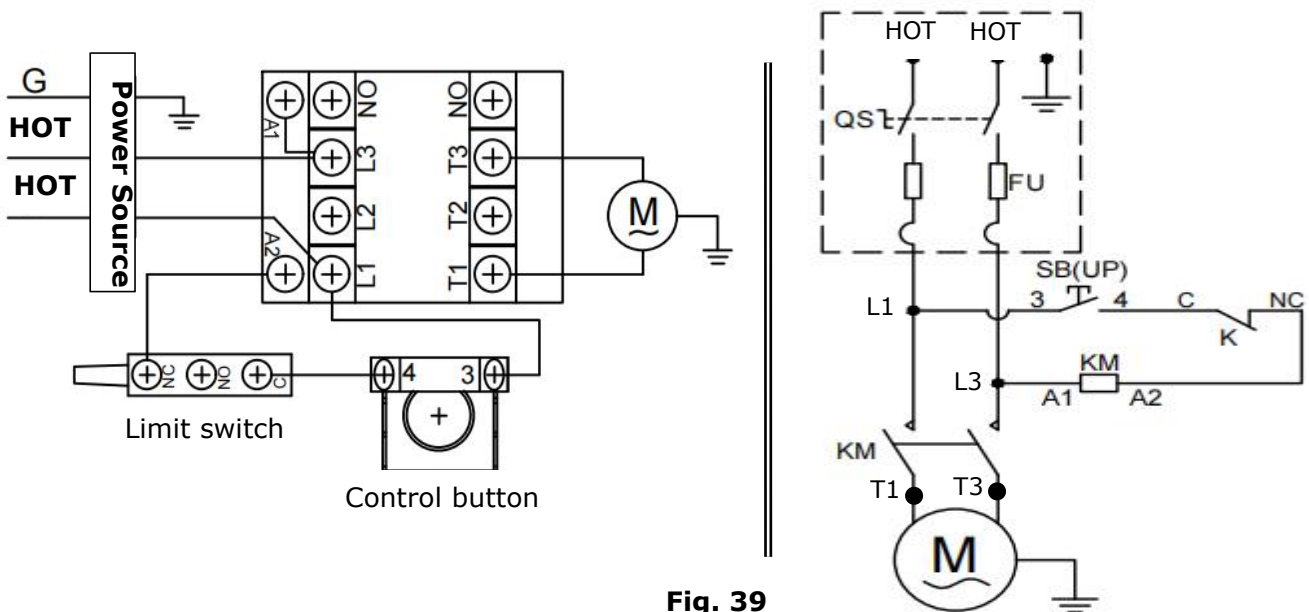

Fig. 39

⚠ DANGER All wiring must be performed by a licensed, certified Electrician. If someone who is not a certified Electrician attempts these tasks, they could damage the Lift or be electrocuted, resulting in serious injury or even death.

⚠ DANGER The Power Unit's motor should not be located in a recessed area or below floor level. Never expose the motor to rain or other damp environments; damage to the motor caused by water is not covered by the warranty.

2. Connecting the limit switch wire: Remove the short wire that connects # 4 and # A2 as shown in Fig.40. Then according to the wire number of the limit switch, connect them respectively to terminal 4# of control button and A2# of AC contactor.

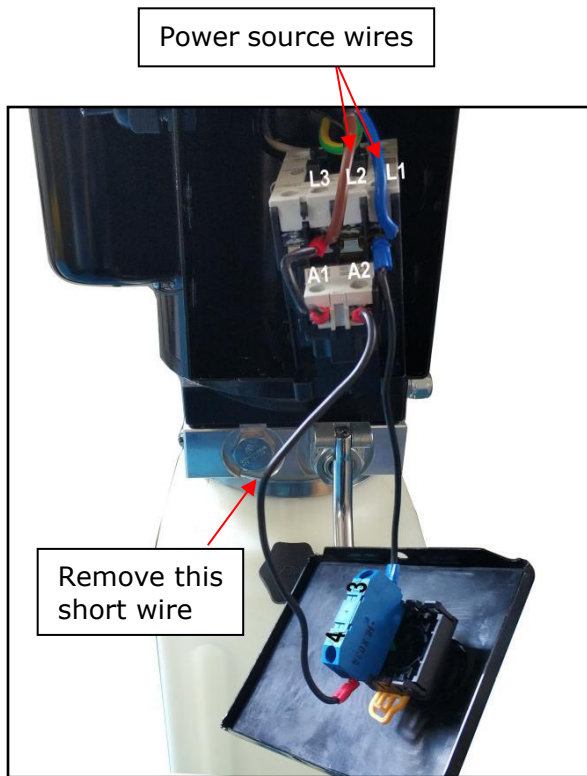

Fig. 40

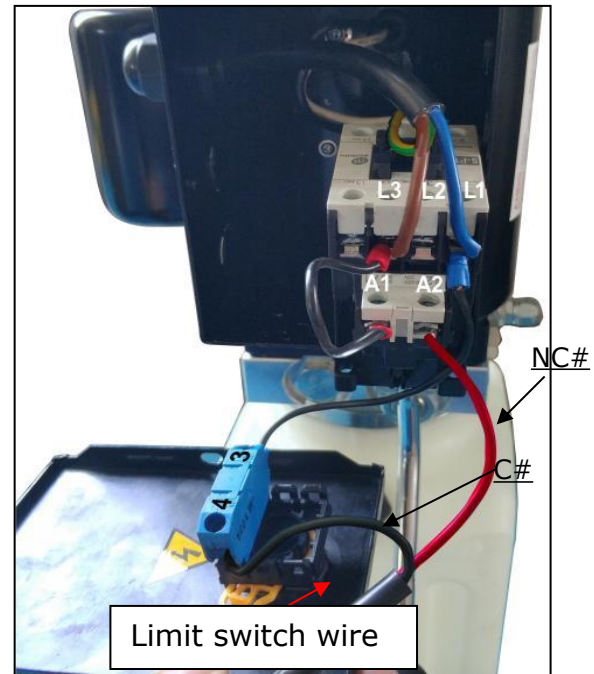

Fig. 41

Important note These instructions must be followed:

1. This equipment has internal arcing or parts that may spark and should not be exposed to flammable vapors.
2. The Power Unit's motor should not be located in a recessed area or below floor level.
3. Do not run the power unit without oil, the oil pump may be damaged.
4. The power unit must be kept dry. Damage to electrical installations caused by water or other liquids such as detergents, acids, etc., is not covered by the warranty.
5. Incorrect electrical connections can damage the motor and will not be covered by the warranty.
6. If there is no physical change in the motor, the motor cannot run at 50Hz.(Only for USA)
7. Use a separate circuit breaker for each power unit.
8. Protect each circuit with a delay fuse or circuit breaker.(Only for USA)

⚠ **DANGER** All wiring must be performed by a licensed, certified Electrician. If someone who is not a certified Electrician attempts these tasks, they could damage the Lift or be electrocuted, resulting in serious injury or even death.

⚠ **DANGER** If the wire is damaged or badly worn, refrain from using the lift. In case of raising the vehicle without noticing any damage or wear, lower it to the ground with utmost care. Once lowered, immediately disconnect and remove power supply.

IV. EXPLODED VIEW

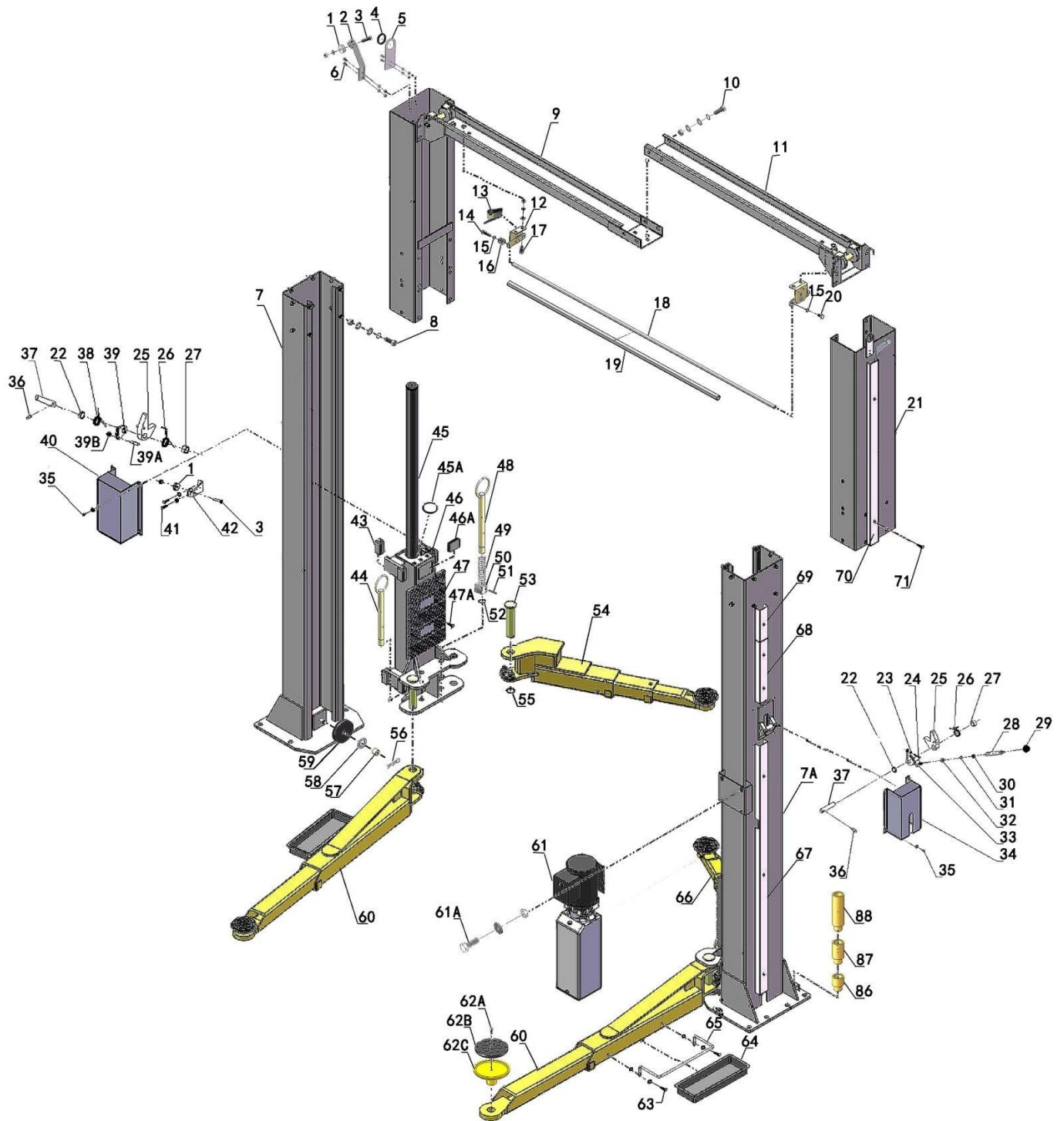

Fig. 42

PARTS LIST

Item	Part No.	Description	QTY.
1	10206009	Small pulley(White)	3
2	11217379	Safety Cable Bracket	2
3	1002215005	Hex bolt(M10*35), Lock washer, nut	2
4	1061K074	Protective ring	2
5	11217024	Oil hose retainer	2
6	1002215011	Hex bolt(M6*15), lock washer, flat washer, nut	10
7	11279024	Off-side inner column	1
7A	11279023	Power-side inner column	1
8	1002215006	Hex bolt(M10*30),lock washer,dual flat washers,nut	20
9	11206196-01	Top beam B	1
10	1002215008	Hex bolt(M12*20), lock washer, flat washer, nut	14
11	11206195-01	Top beam A	1
12	1103072003A	Control bar fixing bracket	2
13	1002075003	Limit switch assy.(Include wire L=145-21/32")	1
14	10201122	Hex bolt (M8*35)	1
15	10209034	Spring washer Φ 8	2
16	110207007	Connecting Sleeve ϕ 14*2*20	1
17	1002215007	Hex bolt(M10*20),lock washer, flat washer, nut	4
18	1102072001A	Control bar ϕ 22*2400(L=94-1/2")	1
19	10206025A	Foam Cushion with handle	1
20	10201002	Hex bolt M8*16	1
21	11203221	Outer column L=1240mm (48-13/16")	2
22	11217012	Safety device spacer ϕ 27*10	2
23	10217010	Hex bolt M6*40	1
24	10217011	Hex bolt M6	1
25	11217009	Main lock	2
26	10217030	Spring ϕ 2.0*120°	2
27	11217436	Safety device spacer ϕ 27*15	2
28	11217006	Safety lock handle	1
29	10217005	Plastic ball M10	1
30	10420026	Spring washer ϕ 12	1
31	10206006	Washer ϕ 12	1
32	10206023A	Hex nut M12	1
33	11217004	Active safety control block	1
34	11217405	Power-side safety cover	1
35	1002215013	Round head bolt M6*8, flat washer	8
36	10217051	Socket bolt M10*10	2
37	11217050	Safety device pin	2
38	10217008	Torsion spring ϕ 2.5*145°	1
39	11217031	Driven safety control block	1

Item	Part No.	Description	QTY.
39A	10217032	Cable connecting pin	1
39B	11217033	Nylok Nut	1
40	11217406	Off-side safety cover	1
41	1002215012	Hex bolt(M6*15), flat washer	2
42	11217029	Safety Pulley Bracket	1
43	10209015	Slider	16
44	11217046	Arm lock bar(Right)	2
45	1002216000	Cylinder $\phi 50 \times 1727$ (L=68")	2
45A	10209111	Cylinder protective ring	2
46	11279004	Carriage	2
46A	10209016	Plastic cover	2
47	10209018	Protective rubber block	2
47A	10209019	Flat Head Screw M6*16	12
48	11217046A	Arm lock bar(Left)	2
49	10206050A	Spring	4
50	10217044-01	Arm lock	4
51	10206036	Snap pin $\phi 6 \times 40$	4
52	10206032	Clip ring $\phi 25$	4
53	11217168	Arm pin	4
54	1102214005C	Front left arm assy.	1
55	10520023	Clip ring $\phi 38$	4
56	10209012	Snap pin $\phi 3.2$	2
57	10209128	Washer $\phi 20$	4
58	1002011001	Bronze bush $\phi 22 \times \phi 19 \times 14$	6
59	1102011001	Pulley $\phi 80 \times \phi 22 \times 15$	6
60	1102214001C	Rear arm assy.	2
61	071101	Power unit	1
61A	1002215009	Hex bolt(M8*25),Rubber pad($\phi 8 \times 20 \times 3$),nylok nut	4
62	10201046A	Rubber pad assy.	4
62A	10420138	Socket bolt M6*16	12
62B	10209134	Rubber pad	4
62C	11680030C	Rubber pad support frame	4
63	1005014002	Hex bolt(M8*16), lock washer, flat washer	4
64	10206156	Tool tray	2
65	11206154	Rear guard bar	2
66	1102214012C	Front right arm assy.	1
67	11203778-01	Wire Protective cover L=1560(L=61-13/32")	2
68	11203754-01	Wire Protective cover L=385(L=15-5/32")	2
69	11203752	Wire Protective cover L=1140(L=44-7/8")	2
70	11279624	Wire Protective cover L=200(L=7-7/8")	2
71	10206079	Round head bolt M6 \times 40mm(1-9/16")	18

Item	Part No.	Description	QTY.
72	10209066	Hex nut M16	8
73	10206064A	Cable assy. $\phi 9.52 \times 10048 \text{mm}$ (L=395-19/32")	2
74	10211016	T fitting	1
75	10206130-01	Oil hose assy. 1/4" * 5350mm (L=210-5/8")	2
76	10209064	Straight fitting	2
77	11233009	Straight fitting	2
78	10206062	Straight fitting	2
79	10206132-01	Oil hose assy. 1/4" * 4470mm (L=175-31/32")	1
80	10209060	Power unit 90° fitting	1
81	1102075001	Cable limit plate	4
82	1002215010	Socket bolt (M6*16), lock washer, flat washer	8
83	10206149	Safety cable $\phi 2.5 \times 7750 \text{mm}$ (L=305-1/8")	1
84	10209059	Anchor bolt 3/4" * 5-1/2"	12
85	10201090	Shim (1mm=39/100")	10
	10620065	Shim (2mm=79/100")	10
86	11209051B	Stackable extension adapter (1.5")	4
87	11209052B	Stackable extension adapter (2.5")	4
88	11209053B	Stackable extension adapter (5")	4
89	10206500B	Parts box	1
90	10209152	Ziptie 3*150mm=5-9/10"	4

4.1 Rear arm assy. (1102214001C) explosive view

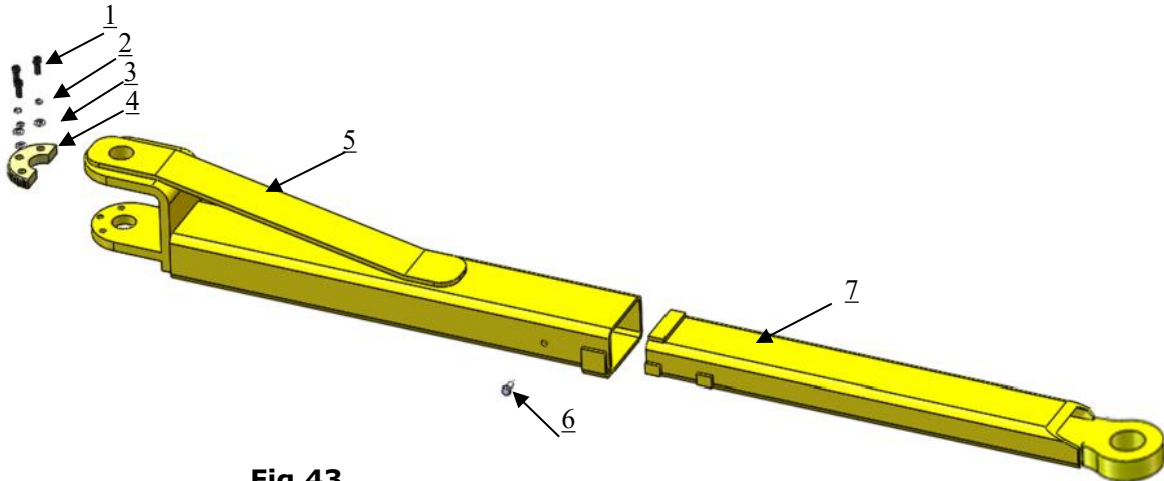

Fig.43

Item	Part No.	Description	QTY.
1	10206048	Socket bolt M10*30	6
2	10209039	Lock Washer $\phi 10$	6
3	10209022	Flat Washer $\phi 10$	6
4	11206049	Moon gear	2
5	1102214001A	Rear outer arm	2
6	10201149	Cap head bolt M8*12	2
7	1102214004A	Rear inner arm	2

4.2 Front left arm assy. (1102214005C) explosive view

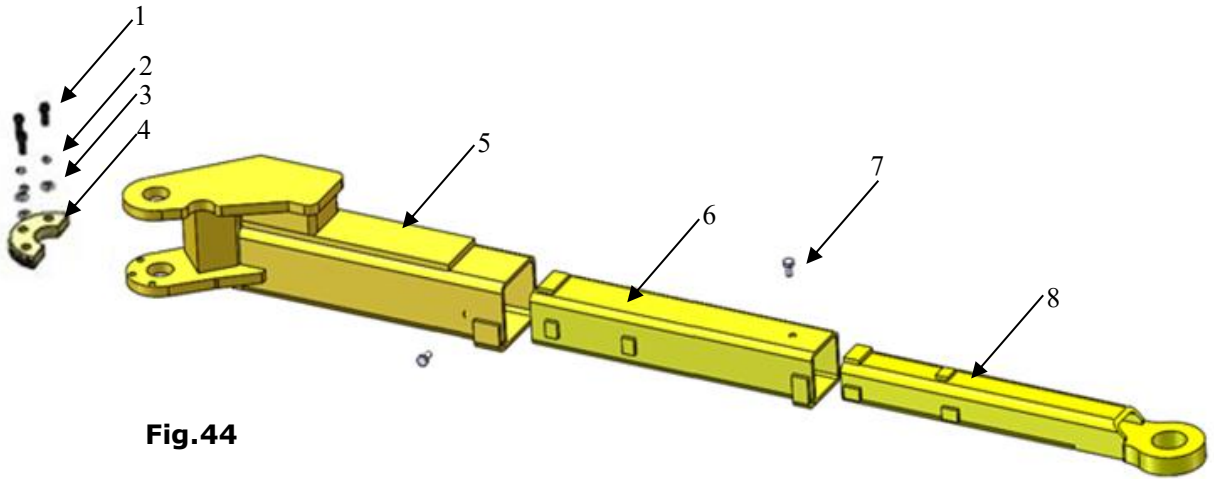

Fig.44

Item	Part No.	Description	QTY.
1	10206048	Socket bolts M10*30	3
2	10209039	Lock Washer φ10	3
3	10209022	Flat Washer φ10	3
4	11206049	Moon gear	1
5	1102214005A	Outer arm-Front left	1
6	1102214009A	Middle arm - Front	1
7	10201149	Round head bolt M8*12	2
8	1102214010A	Inner arm - Front	1

4.3 Front right arm assy. (1102214012C) explosive view

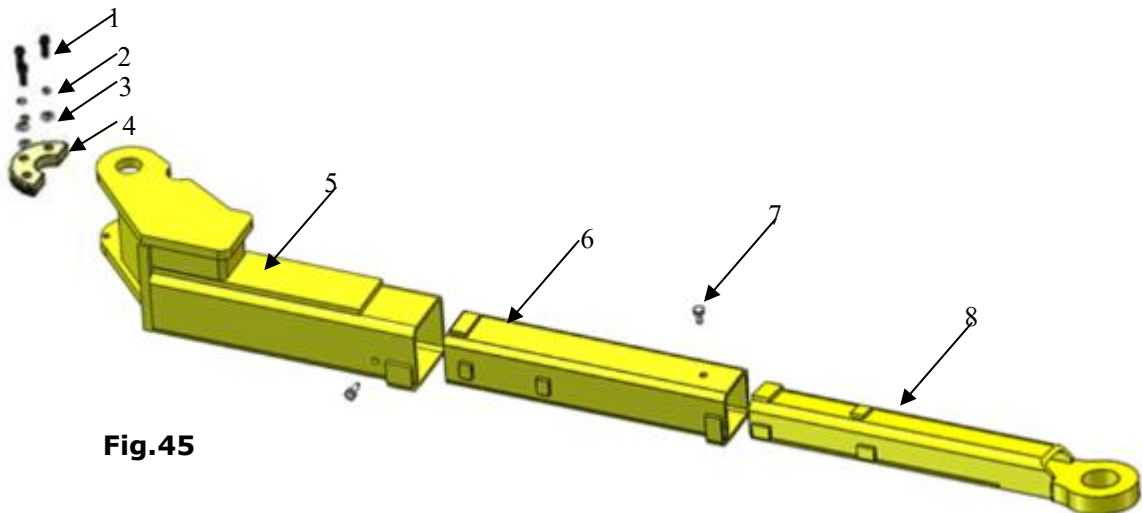

Fig.45

Item	Part No.	Description	QTY.
1	10206048	Socket bolt M10*30	3
2	10209039	Lock Washer φ10	3
3	10209022	Flat Washer φ10	3
4	11206049	Moon gear	1
5	1102214012A	Outer arm - Front right	1
6	1102214009A	Middle arm - Front	1
7	10201149	Round head bolt M8*12	2
8	1102214010A	Inner arm- Front	1

4.4 Cylinder (1002216000) explosive view

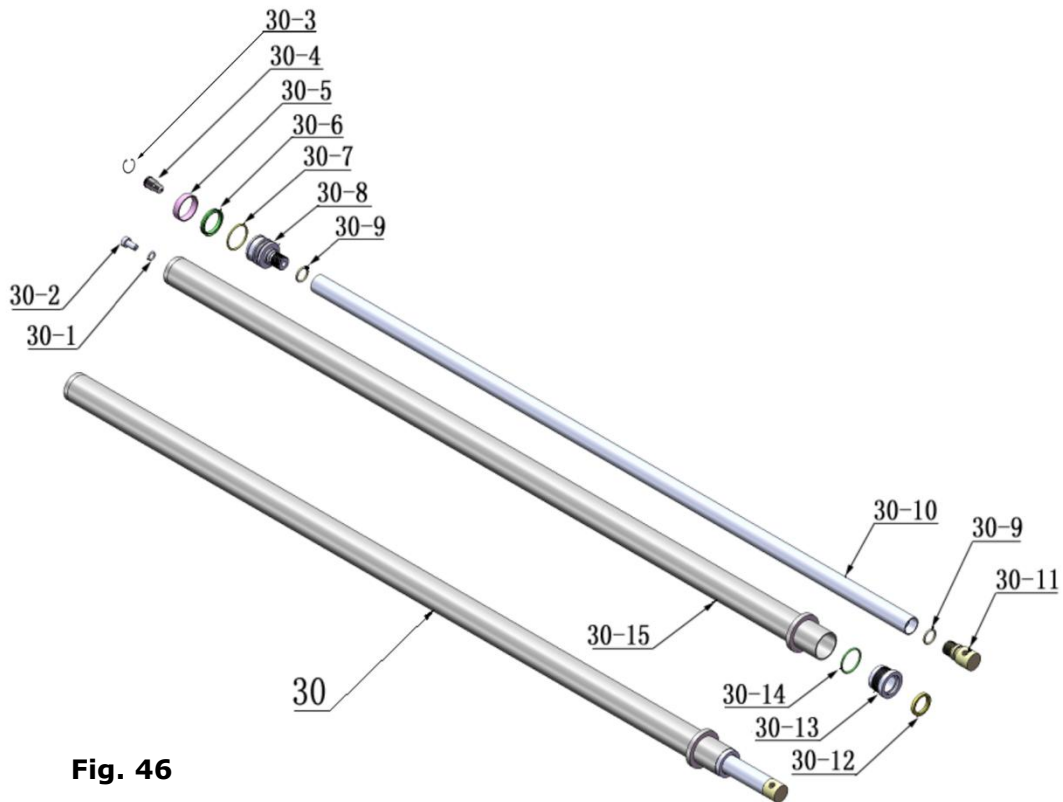
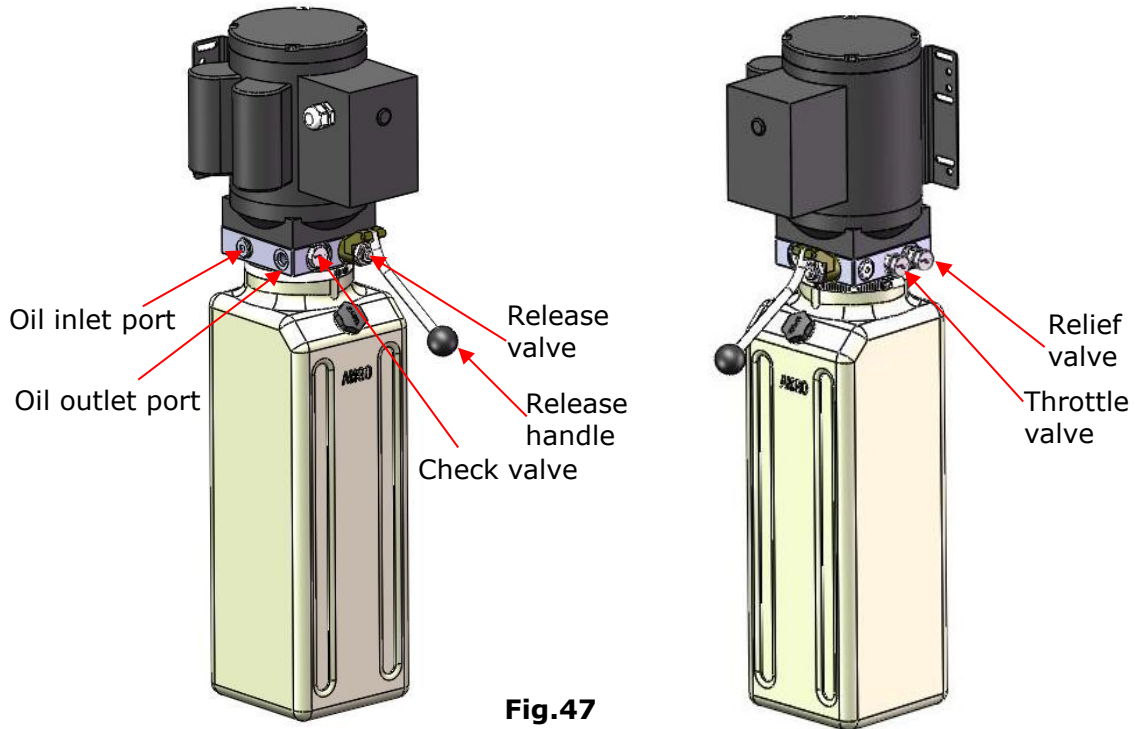

Fig. 46

Item	Part No.	Description	QTY.
30-1	10209069	O-ring	2
30-2	10209070	Bleeding Plug	2
30-3	1002576003	Support Ring	1
30-4	11720114	Pressure Compensated Flow Restrictor (0.7 Spring)	1
30-5	10209071	Wear ring	2
30-6	10209072	Y-ring OSI	2
30-7	10209073	O-Ring	2
30-8	1102576005	Piston	2
30-9	10209075	Piston Rod Fitting	2
30-10	11217076	Piston rod	2
30-11	11209077	Piston Rod Fitting	2
30-12	10209078	Dust wing	2
30-13	11209079	Cover	2
30-14	10209080	O ring	2
30-15	11209081A	Cylinder components	2

4.5 Illustration of hydraulic valve for hydraulic power unit



V. TEST RUN

1. Adjustment of synchronous cable (See Fig. 48)

Use an open spanner to clamp the cable joint, and use a ratchet wrench to tighten the cable nut until the two synchronous cables are adjusted to a certain tension force and are consistent. If the carriage on both sides do not run synchronously when the lift rises/falls, tighten the cable nut on the lower carriage until the lift can rise and fall synchronously.

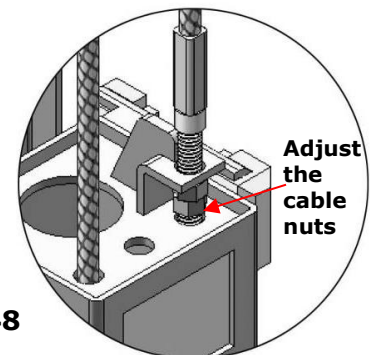

2. Adjust safety cable

Lift both carriages and lock them at the same height, strain the safety cable and then release a little, finally tighten the cable nuts. Ensure that the safety device can always be locked and unlocked properly. At last, install the cover of the safety device.

3. Exhaust air from cylinder

This hydraulic system is designed to bleed air by loosening the bleeding plug. Lift the carriages to a height about 1 meter, loosen the bleeding plug, and the air will be bled automatically. Finally tighten the plug after bleeding, and the lift would work stably and smoothly. Otherwise, repeat these steps. (See Fig. 49)

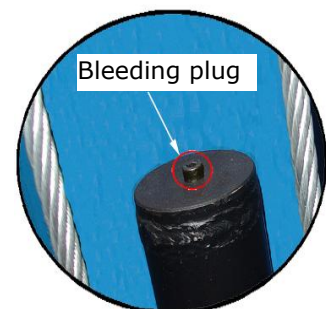

4. Adjust the lower speed

If necessary, you can adjust the lower speed of the lift by turning the throttle valve clockwise to decrease it, or counterclockwise to increase the lower speed.

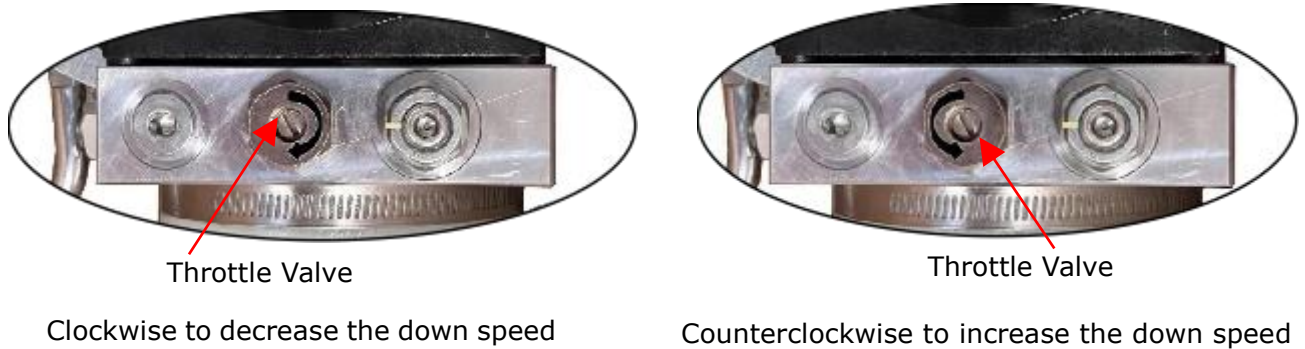

Fig. 50

5. Test with a typical vehicle

The test should be conducted after the above adjustments have been completed, test running the lift with typical vehicle. Run the lift at low level several times first, ensure that both side safety lock can lock and unlock in synchronization. When there is no other abnormal phenomenon, run the whole process. Repeat the above adjustment if there is any abnormal phenomenon.

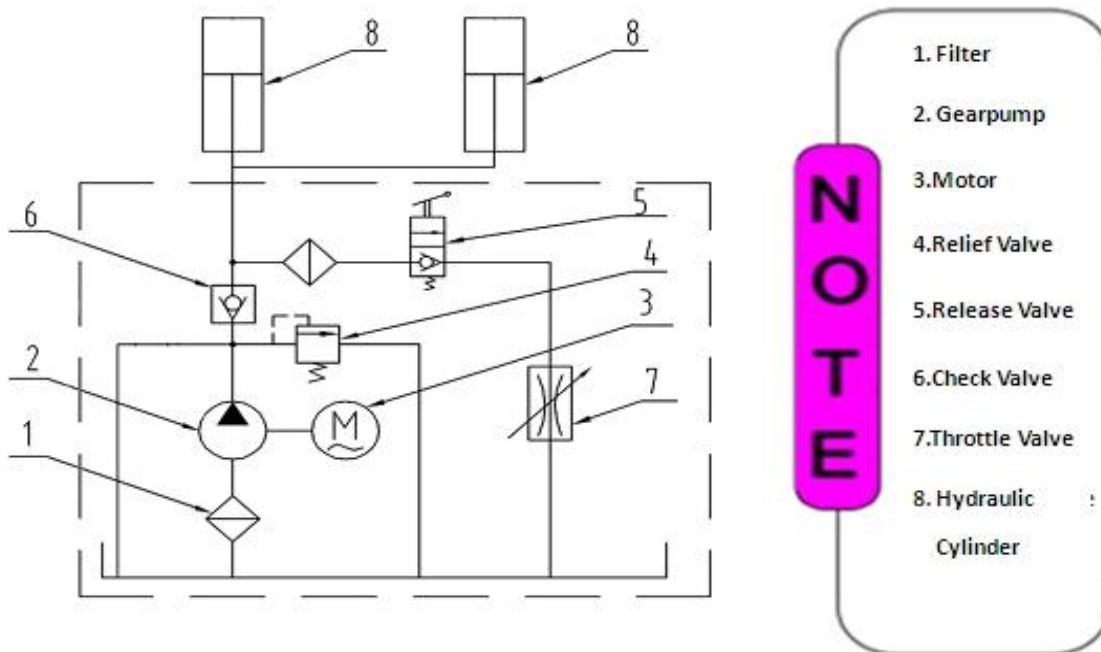

Fig.51

⚠ WARNING Do not lift vehicles that exceed the rated capacity of the lift. Please do not release the safety handle until the lift safety lock is locked. Only trained personnel are authorized to operate the lift.

VI. OPERATION INSTRUCTIONS

Make sure read thoroughly the Important safety instructions before operating the lift. The failure of reading such instructions could lead to serious injury or even death.

To lift vehicle

1. Keep operation site clean;
2. Lower the lifting arm to its lowest position;
3. Retract the lifting arm to the shortest position;
4. Open lifting arms out to the sides;
5. Move the vehicle between columns, the curved arm of the lift is the front;
6. Move the lifting arms to the vehicle's lifting point;

ATTENTION: Use the carrier adapter provided by the PEAK manufacturer.

Swing the lifting arms under the vehicle, lift the vehicle lifting points as recommend by the vehicle manufacturer. If necessary, use the stackable extension adapter or optional saddle adapter to ensure good contact.

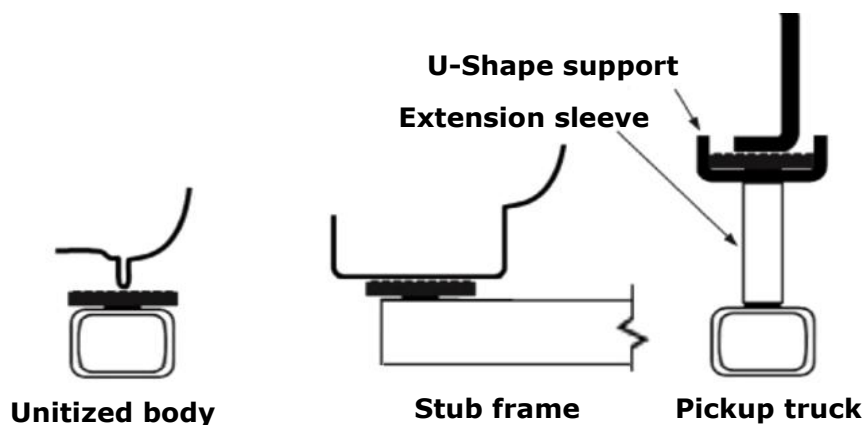
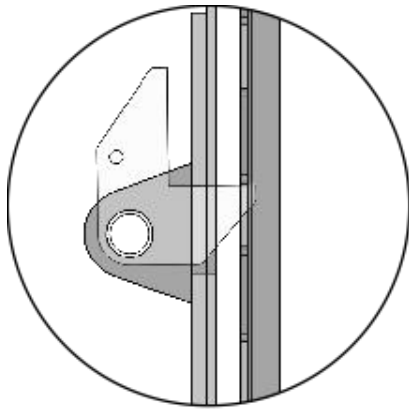

Fig.52

ATTENTION: All four lifting arms must simultaneously touch the vehicle. Lift the vehicle lifting points as required by the manufacturer.

7. Push **UP** button until the lifting pads contact underside of vehicle totally and recheck lifting points;
8. Continue to raise the lift slowly, ensure the balance of vehicle, lift the vehicle to the desired height, release the **UP** button.
9. Press the release handle on power unit to lower the lift to the safety lock position (See Fig.53). The vehicle cannot be repaired unless safety in lock position.



Safety lock working status

Fig.53

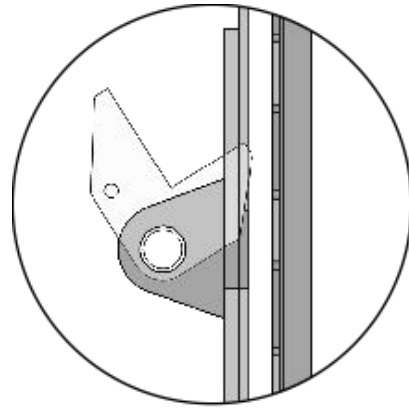

Safety lock being open

Fig.54

To lower vehicle

1. Clear obstructions around and under the lift and be certain no people are around the lift;
2. Push **UP** button to raise the vehicle slightly, and then unlock the safety device, lower vehicle by pushing release handle on the power unit.
3. Open the lifting arms out to the sides and retract the lifting arm to the shortest position;
4. Drive away the vehicle.

⚠ WARNING It is unsafe to work when the lift without locking at safety device after it has been raised. The vehicle may fall, potentially causing damage the vehicle and lift, even causing injury or death to someone nearby.

⚠ DANGER When using the lifting points on the chassis recommended by the vehicle manufacturer, be sure to follow the instructions carefully. If you don't, the vehicle can become unstable and fall, which can damage the vehicle and lift, injure or even kill anyone under the vehicle.

TYPICAL LIFTING POINTS

ATTENTION: Some vehicles may have the manufacturer's Service Garage Lift Point locations identified by triangle shape marks on its undercarriage (reference SAE J2184). There may also be a label located on the right front door lock face showing specific vehicle lift points.

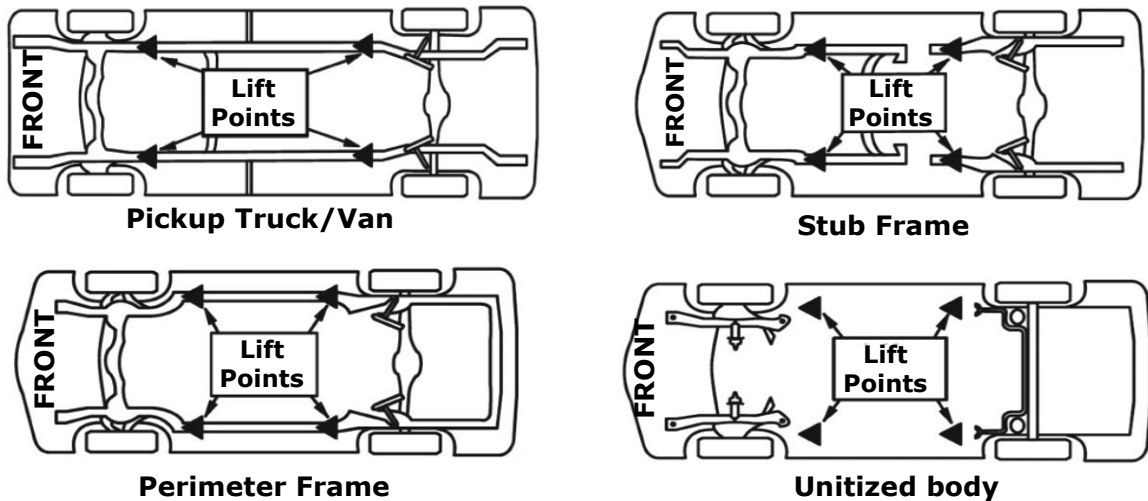

Fig.55

⚠ WARNING Any special or modified vehicles or vehicles with abnormally short or long wheelbases cannot be lifted in a two post lift. Please contact the vehicle manufacturer for details on lifting or jacking.



Fig.56

Place the vehicle with the appropriate weight distribution on the arms so that the adapter is in contact with the manufacturer's recommended lift point.

VII. MAINTENANCE SCHEDULE

Before starting the maintenance of the lift, the **trained lift service personnel** should provide the warning or remark according to ANSI Z244.1-1982 (R1993) , Energy Cut / Warning Marking Safety Requirements.

Cable inspection and maintenance

1. The cables should be replaced every three to five years or when there are obvious signs of damage. Do not use lifts with defective or worn cables.
2. Make sure the cables are always be in good lubrication condition. The cables are fully protected when every cable is lubricated inside and outside. Excessive wear will shorten the service life of the cables. Recommended lubricant is 90WT and provide long lubricating gear oil or ALMASOL® lubricant. To ensure that the inner layer of the cable is well lubricated, lubrication shall be done at no more than three months during the operation.
3. The pulley and guide rollers in contact with the cables shall be regularly inspected for surface wear and lubrication to ensure they operate freely. This operation shall be performed at appropriate intervals, generally not more than three months. For all pulley wheel shafts, the standard wheel bearings grease is recommended. For all pulleys and / or rollers, 90WT gear oil or similar heavy lubricant is recommended applied by any method including pump/spray dispensing,brush,hand and/or swabbing.

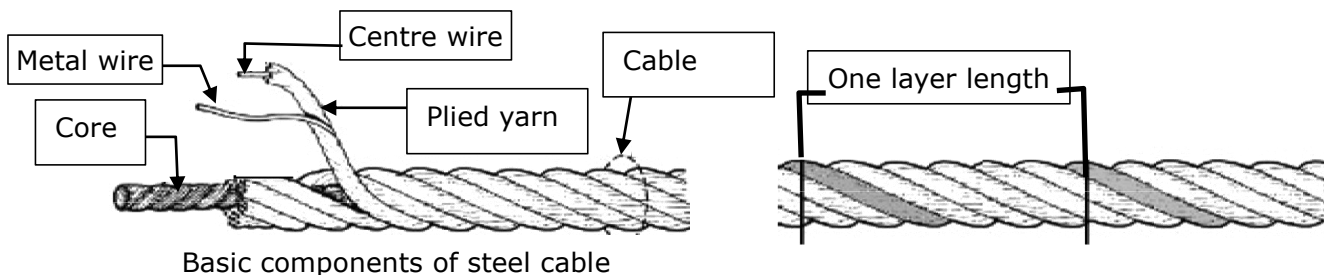



Fig.57

Monthly:

1. Tighten the anchor bolts with to 150 Nm torque force;
2. Check all fittings, bolts and pins to ensure proper connections;
3. Lubricate cable and slider with lubricant;
4. Make a visual inspection of all oil hoses/lines for possible wear or leakage;
5. Check safety device and make sure proper condition;
6. Lubricate all rollers and pins with 90Wt gear oil;

ATTENTION: All anchor bolts should take full torque. If any of the bolts does not function for any reason, DO NOT use the lift until the bolt has been replaced.

 **WARNING** Always use parts provided by the PEAK lift manufacturer or authorized by the manufacturer, if you use non-standard parts obtained from other sources resulting in damage to the lift is not covered by the warranty, and the use of non-standard parts may endanger the safety of the installer/operator.

 **CAUTION** As recommended by American Petroleum Institute (API) RP54 guidelines, cable should be visually inspected at least once a day.

Every six months:

1. Make a visual inspection of all moving parts for possible wear, interference or damage.
2. Check and adjust as necessary, equalizer tension of the cables to insure level lifting.
3. Check columns for plumpness.
4. Check Rubber Pads and replace as necessary.
5. Check limit switch and make sure in proper condition.
6. Check the oil level of power unit and ensure is normal.
7. Check the moon gear and arm lock and ensure in proper condition.

Cylinder maintenance:

In order to extend the service life of the oil cylinder, please operate according to the following requirements.

1. Recommend to use N46 anti-wear hydraulic oil;The maximum oil volume of power unit is 11L.
2. The hydraulic oil of the lift should be replaced regularly during use. Replace the hydraulic oil 3 months after the first installation, Replace the hydraulic oil once a year afterwards.
3. Make at least one full trip raising and lowering per day. For exhausting the air from the system, which could effectively avoid the corrosion of the cylinder and damage to the seals caused by presence of air or water in the system.
4. Protect the outer surface of the oil cylinder's piston rod from bumping and scratching, and timely clean up the debris on the oil cylinder dust-ring and the piston rod.

 **DANGER** Ensure that the lift is completely disconnected from the power supply before performing any maintenance on the lift. If your lift external electrical devices have locks/shutdowns, make sure to implement them before performing any maintenance. If you come into contact with high voltage/current, it may result in injury or even death.

 **DANGER** Pay attention when installing, operating, maintaining, or repairing the lift. Failure to comply the requirements may lead to property damage, product damage, injury, or, (in very rare cases) death.

ATTENTION: Once the vehicle is struck in the air, follow the operating steps instruction shown on P40-42. If the lift still fails to move under standard procedures after observing all mechanic locks released, immediately stop using the lift and contact the manufacturer or the manufacturer's approved service center for further guidance.

VIII.TROUBLE SHOOTING

TROUBLE	CAUSE	REMEDY
Motor does not run	<ol style="list-style-type: none"> 1. Start Button does not work 2. Wiring connections are not in good condition 3. Motor burned out 4. AC contactor burned out 5. Safety protection switch damaged 	<ol style="list-style-type: none"> 1. Replace start button 2.Repair all wiring connections 3. Repair or replace motor 4. Replace AC contactor 5. Replace
Motor runs but the lift is not raised	<ol style="list-style-type: none"> 1. Gear pump out of operation 2. Release valve in damage 3. Relief valve or check valve in damage 4. Low oil level 	<ol style="list-style-type: none"> 1.Repair or replace 2. Repair or replace 3.Repair or replace 4.Fill tank
Lift does not stay up	<ol style="list-style-type: none"> 1. Release valve out of work 2. Relief valve or check valve leakage 3. Cylinder or fittings leaks 	Repair or replace

Lift raises slowly	<ol style="list-style-type: none"> 1. Oil line is jammed 2. Motor running on low voltage 3. Oil mixed with air 4. Gear pump leaks 5. Overload lifting 	<ol style="list-style-type: none"> 1. Clean the oil line 2. Check electrical system 3. Fill tank 4. Replace pump 5. Check load
Lift cannot lower	<ol style="list-style-type: none"> 1. Safety device are in activated 2. Release valve in damage 3. Safety cable broken 4. Oil system is jammed 	<ol style="list-style-type: none"> 1. Release the safeties 2. Repair or replace 3. Replace 4. Clean the oil system

 **WARNING** Lifts are dangerous when operated by inexperienced or distracted individuals. Operators must be fully aware that lifting a car is a potentially life-threatening operation, especially if mandatory safety precautions are disregarded.

IX. CAR LIFT SAFETY TIPS

Put these safety tips in a place where you can always alert the operator. Please reference to the lift manufacturer’s manual for specific information about the lift.

1. Check the lift daily. If the machine breaks down or has damaged parts, do not operate, and use the parts of original equipment to repair.
2. Do not overload the lift. The rated weight of the manufacturer design is indicated on the label of the lift.
3. Position control of the vehicle and operation of the lift can only be done by a trained and authorized person.
4. You can not lift a car with people inside. When the lift is working, the customer or other people should not be around the machine.
5. Keep the place around the lift clear of obstacles, lubricants, grease, garbage and other debris for a long time.
6. Before driving the car into the lift, put the lifting arm and rubber pad in the proper position to ensure barrier-free space. Do not hit or run over the lift arm and rubber pad of the lift, otherwise it will cause damage to the lift machine or the car.
7. Rise the lift to the required height for operation. **Note**, if you are working under a car, raise the lift high enough and make sure the safety device has locked.
8. Note, removing(or installing) parts from a car can cause a sudden shift of gravity

that is unstable for the raised car. Reference to the car manufacturer's service manual as a recommended procedure when removing parts from the car.

9. Before lower the lift , make sure that the tool tray, tool rack, etc. are removed from under the car. Open the lock before lowering the lift.
10. Before removing the car from the lift, put the lifting arm and rubber pad in place to open an unobstructed exit.

X. LIFT DISPOSAL

When the car lift cannot meet the requirements for normal use and needs to be disposed, please follow local laws and regulations.



PEAK CORPORATION

No. 3 Luomu Road.Shishan Town.Nanhai
Foshan(528225),Guangdong,China

Tel: 86-757-81102815 81102805

Fax: 86-757-81102809