

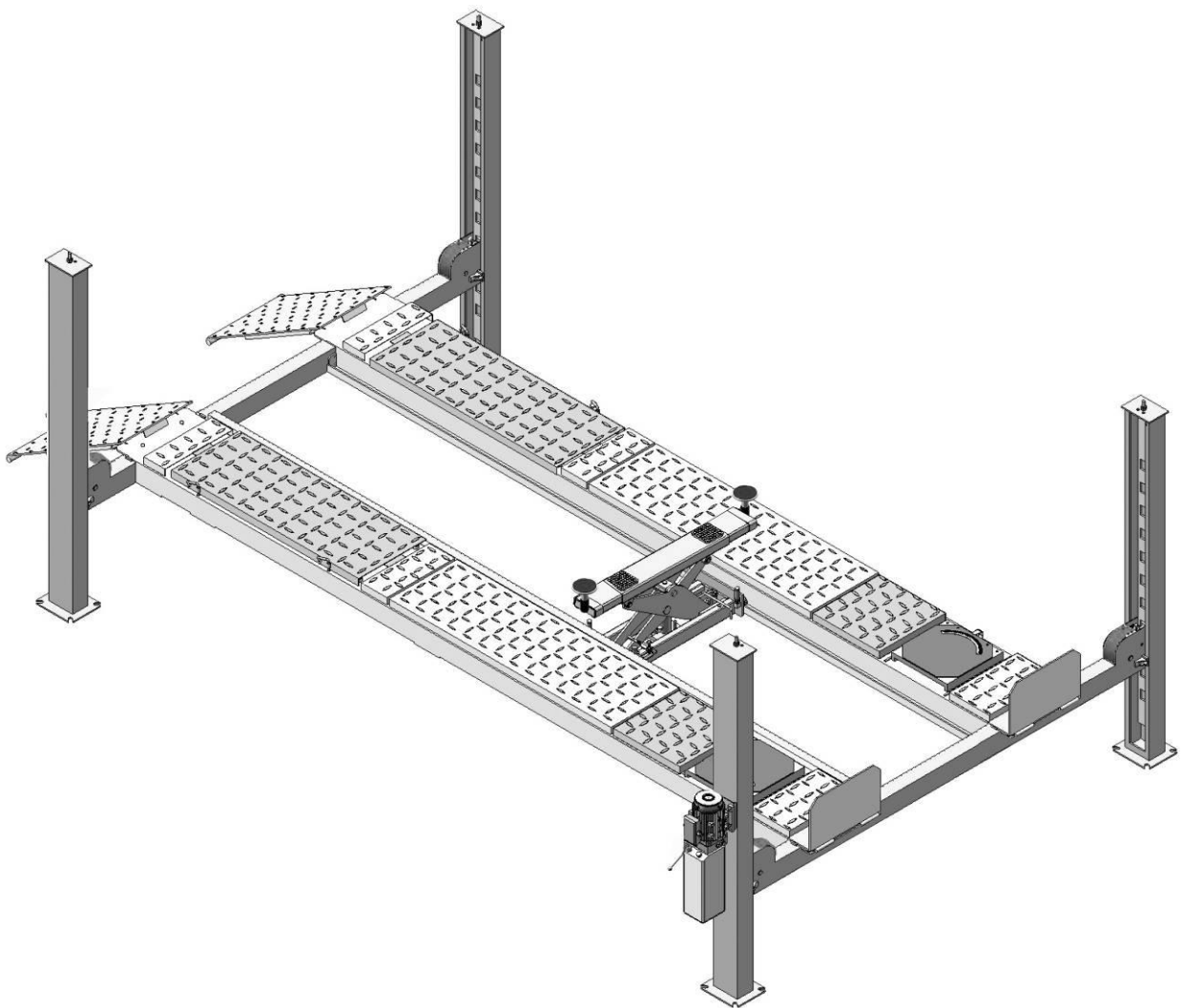

Original

Installation And Service Manual



4-post Lift

Model: KAL-12, KAL-12A, KAL-12AX

CONTENTS

Product Features and Specifications	1
Installation Requirement	2
Steps of Installation	5
Exploded View	24
Test Run	34
Operation Instruction	35
Maintenance	35
Trouble Shooting	37
Lift Disposal.....	37

I. PRODUCT FEATURES AND SPECIFICATIONS

FEATURES

- Manual control air-operated system.
- Mechanical self-lock and air-driven safety release.
- Manual hydraulic power system, cable-driven.
- Strengthen and Non-skid diamond platforms.
- Adjustable platform and adjustable safety lock ladders.
- Optional Jack: With hand pump/Air-operated hydraulic pump/Controlled by power unit.
- Optional Turnplate: Alignment model only

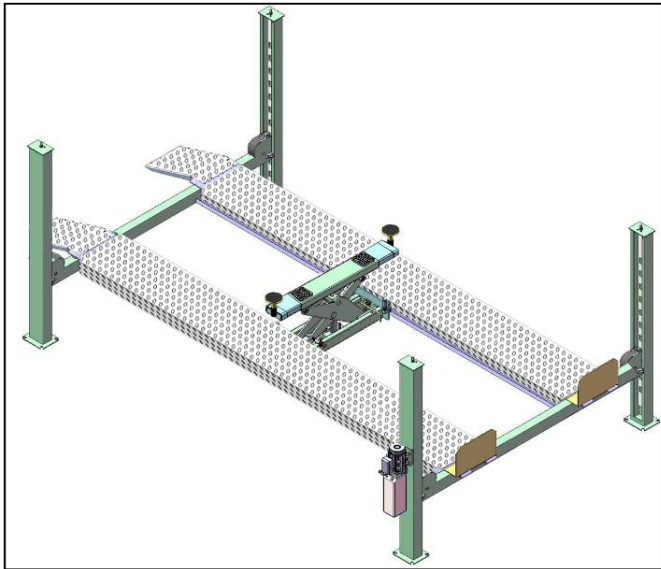

**KAL-12
Fig.1**

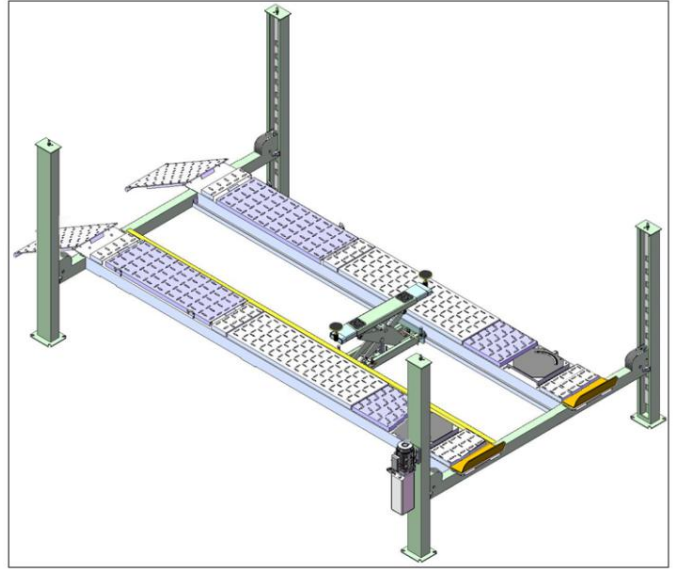

**KAL-12A, KAL-12AX
Fig.2**

ALIGNMENT MODEL SPECIFICATIONS

Model	Lifting Capacity	Lifting Height	Lifting Time	Overall Length (W/ Ramps)	Overall Width	Width Between Columns	Motor
KAL-12	12,000 lbs	1865mm 73 3/8"	60S	6012mm 236 5/8"	3208mm 126 1/4"	2852mm 112 1/4"	4.0HP
KAL-12A	12,000 lbs	1915mm 75 3/8"	60S	6012mm 236 5/8"	3208mm 126 1/4"	2852mm 112 1/4"	4.0HP
KAL-12AX	12,000 lbs	1915mm 75 3/8"	60S	6012mm 236 5/8"	3356mm 132 1/8"	3000mm 118 1/8"	4.0HP

II. INSTALLATION REQUIREMEN

A. TOOLS REQUIRED

- ✓ Rotary Hammer Drill (Φ19)



- ✓ Hammer



- ✓ Level Bar



- ✓ English Spanner (12")



- ✓ Wrench Set
(10#, 12#, 13#, 14#, 17#, 19#, 24#, 30#)



- ✓ Ratchet Spanner with Socket (28#)



- ✓ Carpenter's Chalk



- ✓ Screw Sets



- ✓ Tape Measure (7.5m)



- ✓ Pliers



- ✓ Lock Wrench



- ✓ Socket Head Wrench
(3#, 5#, 6#)



Fig. 3

B. Equipment storage and installation requirements.

The equipment should be stored or installed in a shady, normal temperature, ventilated and dry place.

C. The equipment should be unload and transfer by forklift.



Fig. 4

D. SPECIFICATIONS OF CONCRETE (See Fig. 5)

Specifications of concrete must be adhered to the specification as following.

Failure to do so may result in lift and/or vehicle falling.

1. Concrete must be thickness 100mm minimum and without reinforcing steel bars, and must be dried completely before the installation.
2. Concrete must be in good condition and must be of test strength 3,000 psi (210kg/cm²) minimum.
3. Floors must be level and no cracks.

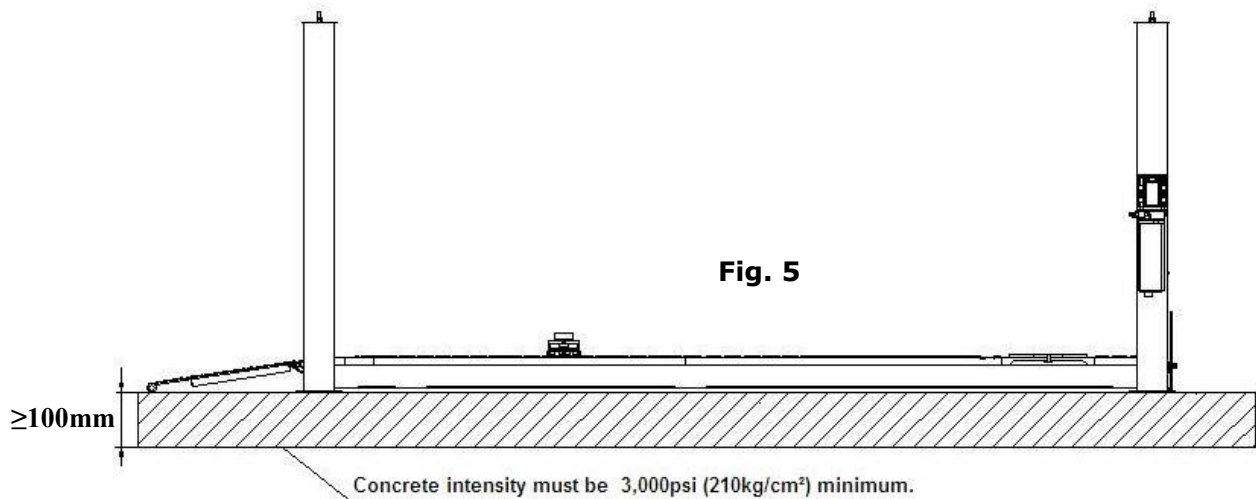

E. AIR SUPPLY

Air pressure requirement: 0.8Mpa, Air line size $\phi 8 \times \phi 6$ and $\phi 6 \times \phi 4$.

F. POWER SUPPLY

The electrical source must be 3KW minimum. The source cable size must be 2.5mm² and in good condition of contacting with floor.

III. STEPS OF INSTALLATION

A. Location of installation

Check and insure the installation location (concrete, layout, space size etc.) is suitable for lift installation.

B. Check the parts before assembly

1. Packaged lift and hydraulic power unit (See Fig. 6).



Fig. 6

2. Open the outer packing carefully (See Fig. 7).

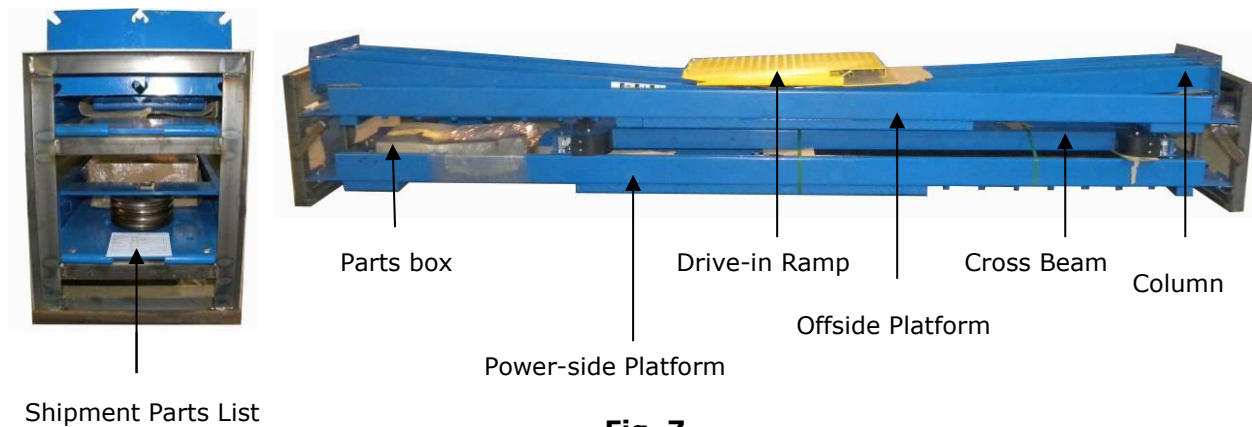

Fig. 7

3. Take off the Drive-in Ramps and Columns (See Fig. 8).



Fig. 8

4. Loose the screws of the upper package stand, take off the offside platform, take out the parts inside the power-side platform, then remove the package stand.

5. Move aside the parts and check the parts according to the shipment parts list (See Fig. 9).

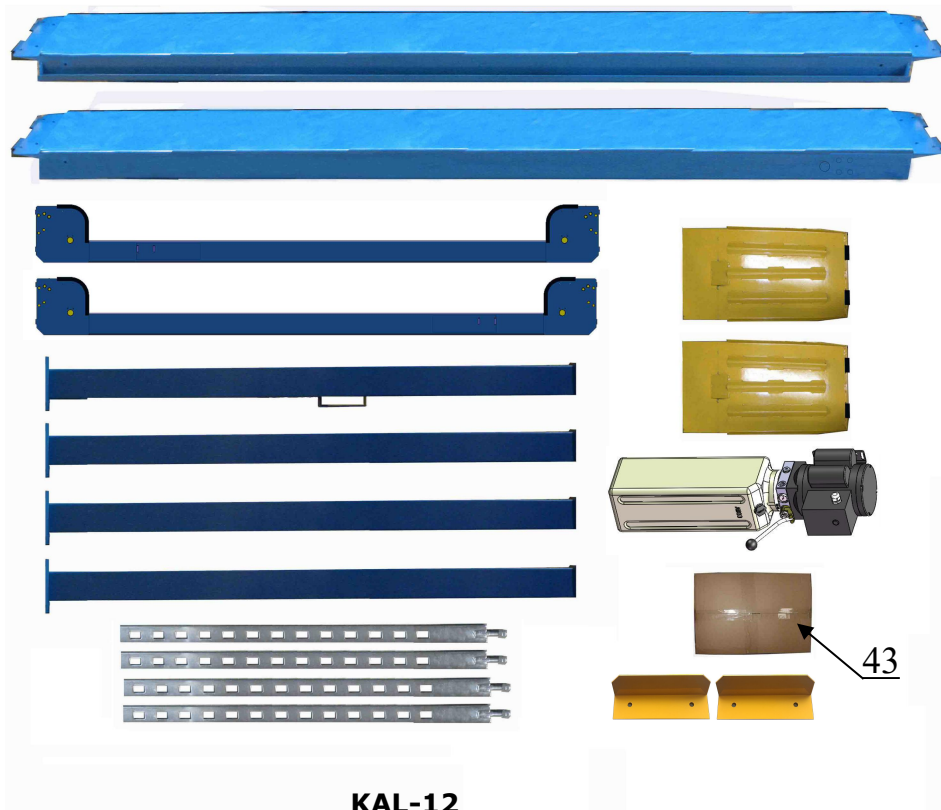

KAL-12
Fig. 9

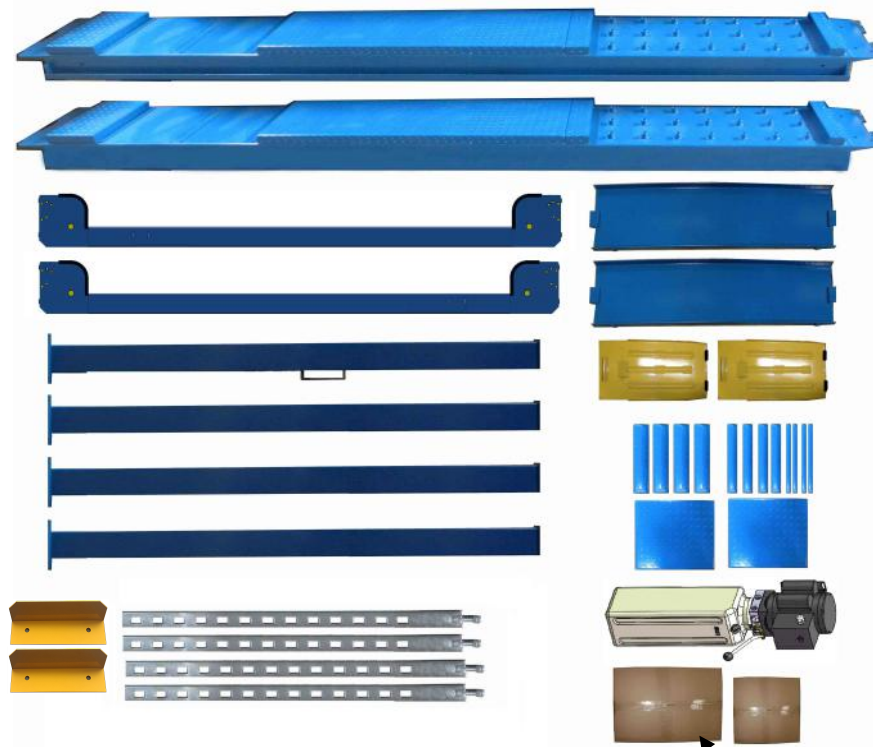

KAL-12A KAL-12AX
Fig. 10

6. Open the carton of parts and check the parts according to the parts box list (See Fig. 11).



Fig. 11

7. Check the parts of the parts bag according to the parts bag list (See Fig. 12).

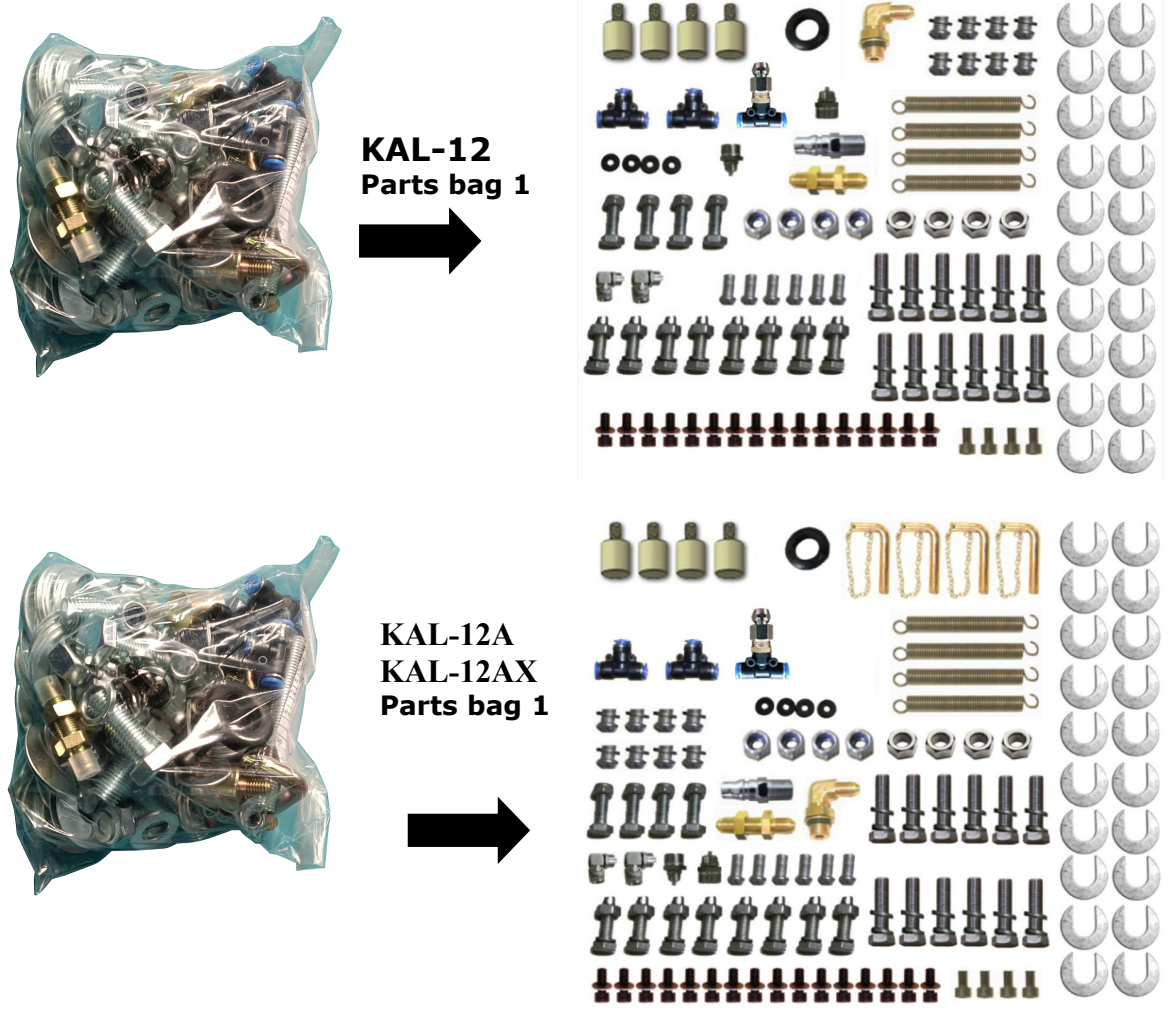

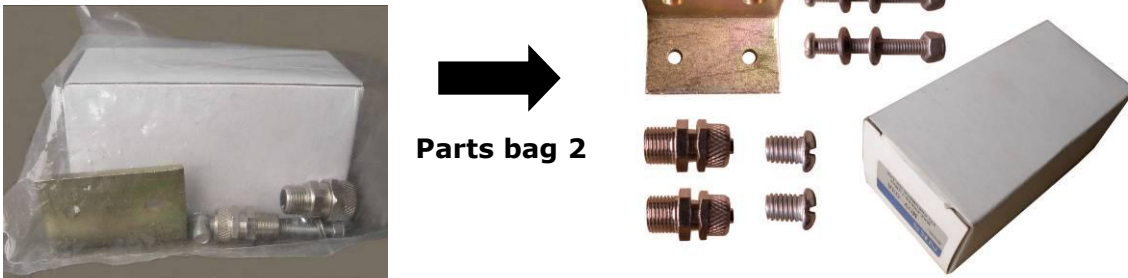

Fig. 12

C. Use a carpenter's chalk line to establish installation layout

Make sure the size is right and base is flat (see Fig. 13).

Note: Reserve space before and behind the installation site.

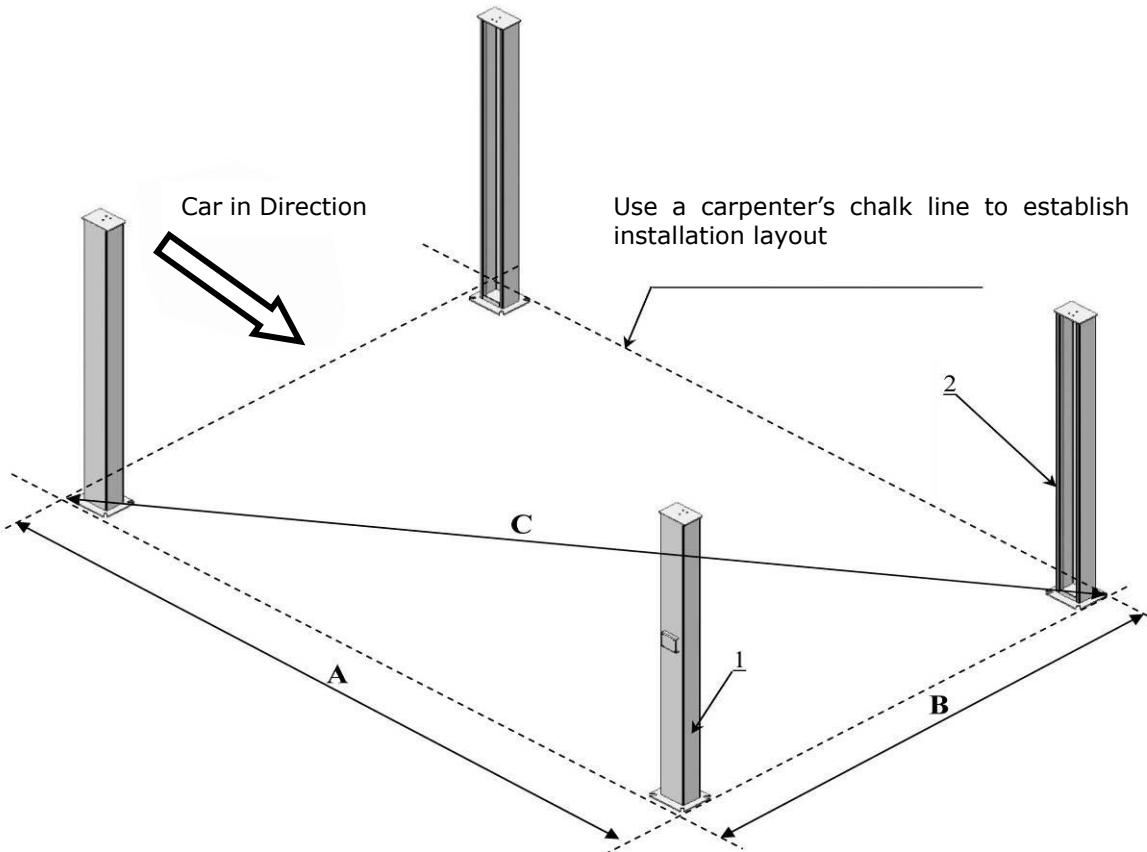

Fig. 13

Model	A	B	C
KAL-12 KAL-12A	5100mm 200 3/4"	3208mm 126 1/4"	6025mm 237 1/4"
KAL-12AX	5100mm	3356mm	6105mm

D. Install cross beams (See Fig. 14, Fig. 15).

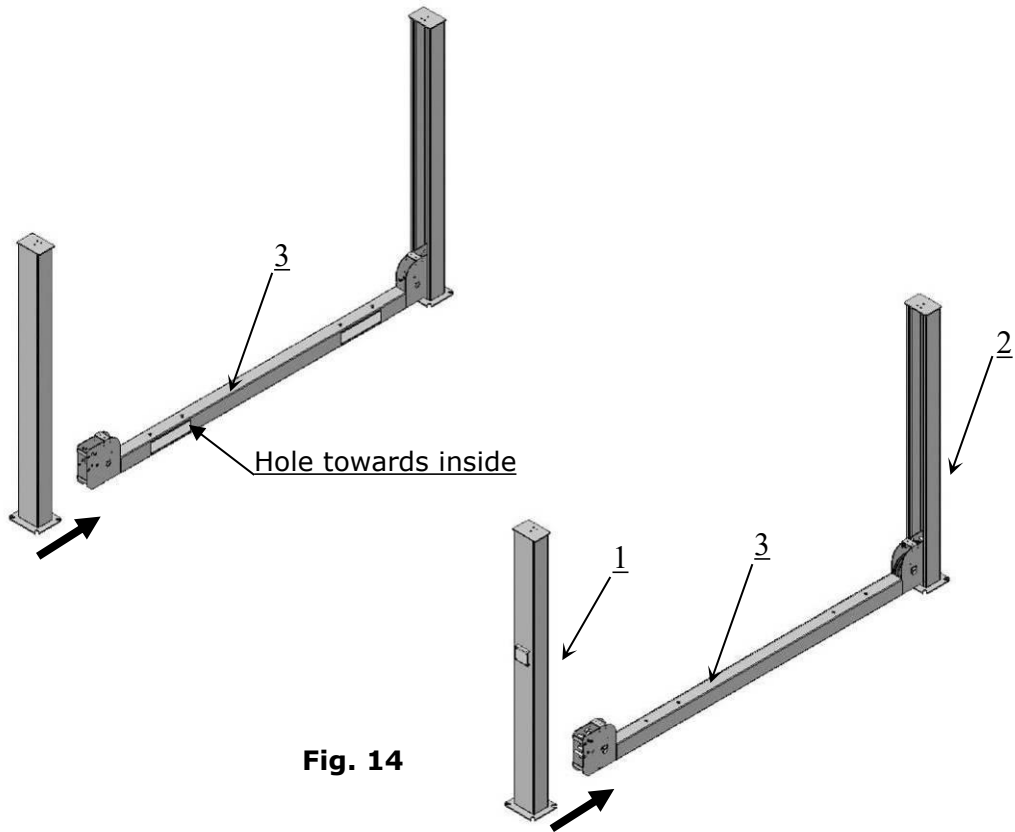

Fig. 14

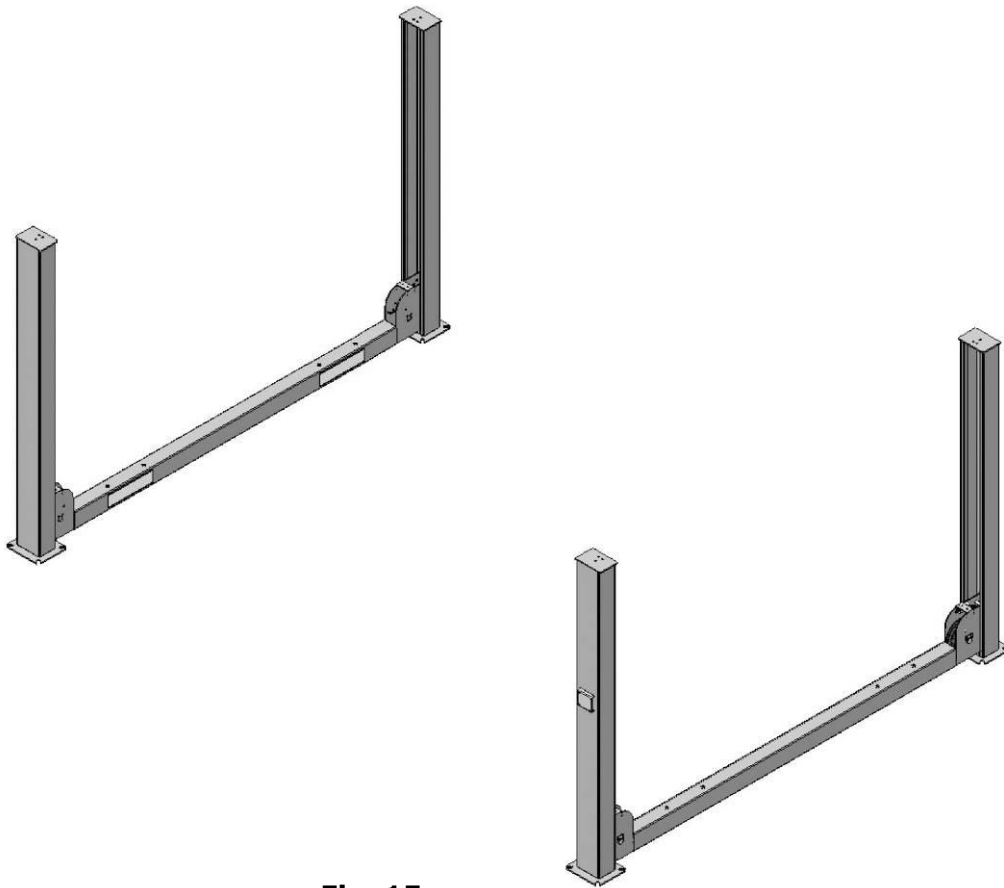

Fig. 15

E. Fix the anchor bolts

1. Prepare the anchor bolts (See Fig. 16).

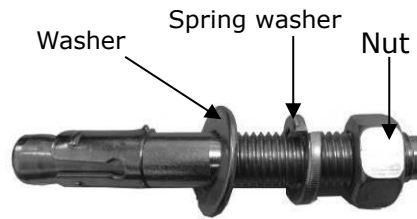
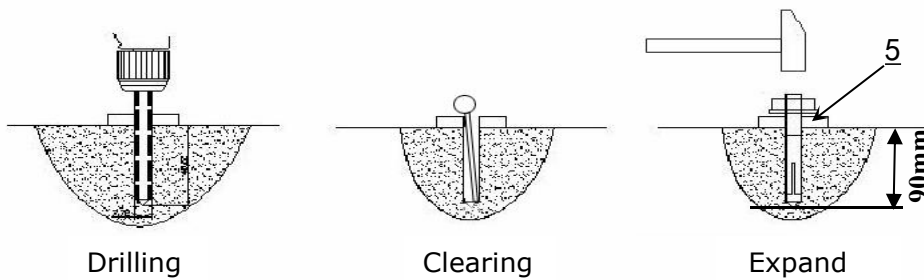

Fig. 16

2. Using the prescribed rotary hammer drill, and drill all the anchor holes and install the anchor bolts, do not tighten the anchor bolts first (See Fig. 17).



Note: Minimum embedment of anchors is 90mm.

Fig. 17

F. Install the safety ladders

1. Take off the pulley safety cover and unscrew the four upper nuts of the Safety Ladders, and then adjust the four lower nuts to be at the same position. Withdraw the Slack-cable safety lock of the Cross-beam to insert the Safety Ladder in, raise the Safety Ladder, and screw the upper nuts (See Fig. 18.)

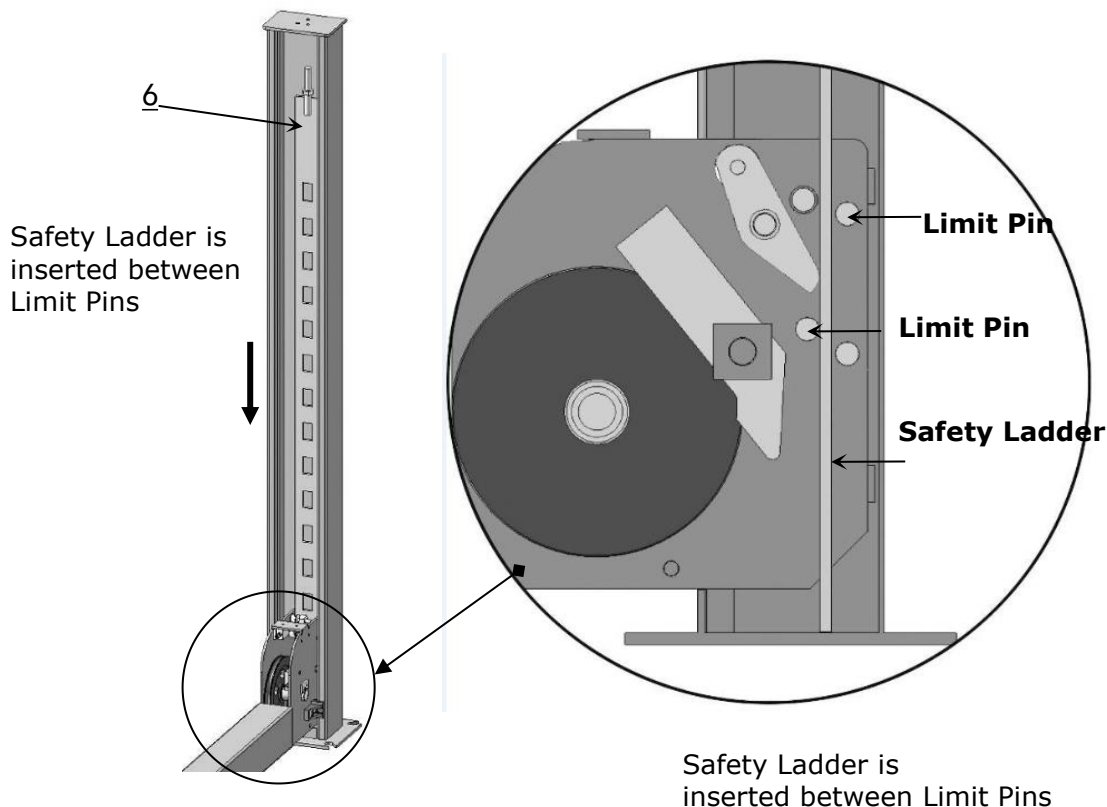
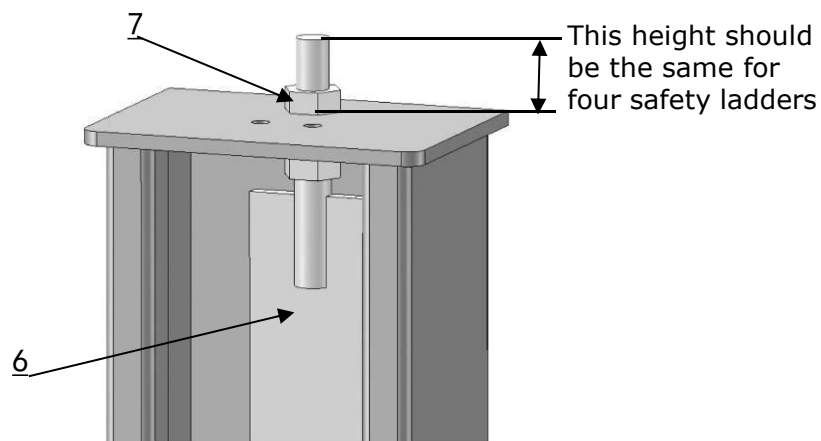

Fig. 18

2. Install safety ladders (See Fig. 19).



Safety ladder pass through the hole of the top plate, then tighten the two nuts

Fig. 19

G. Put the Cross Beams at the same height (See Fig. 20)

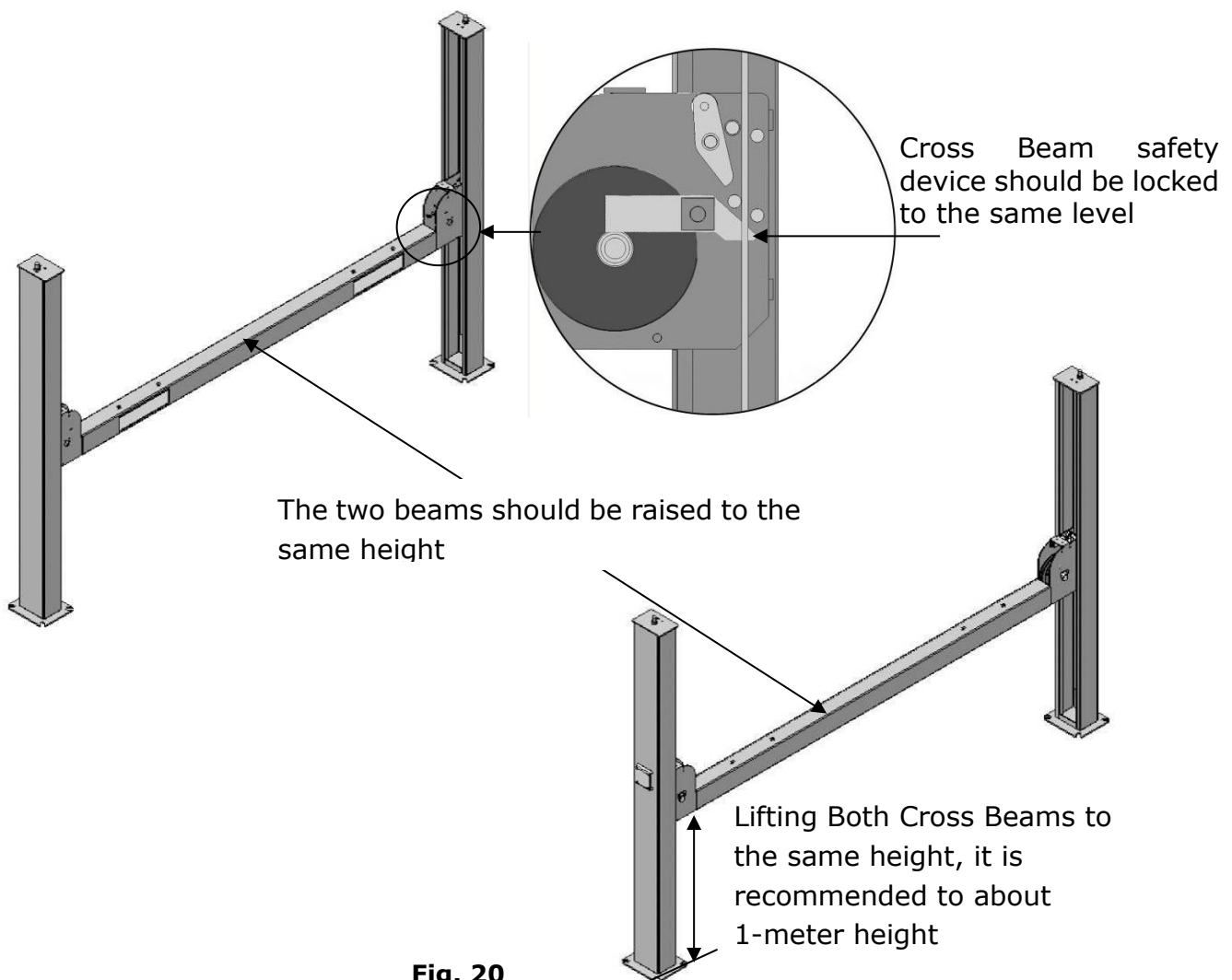
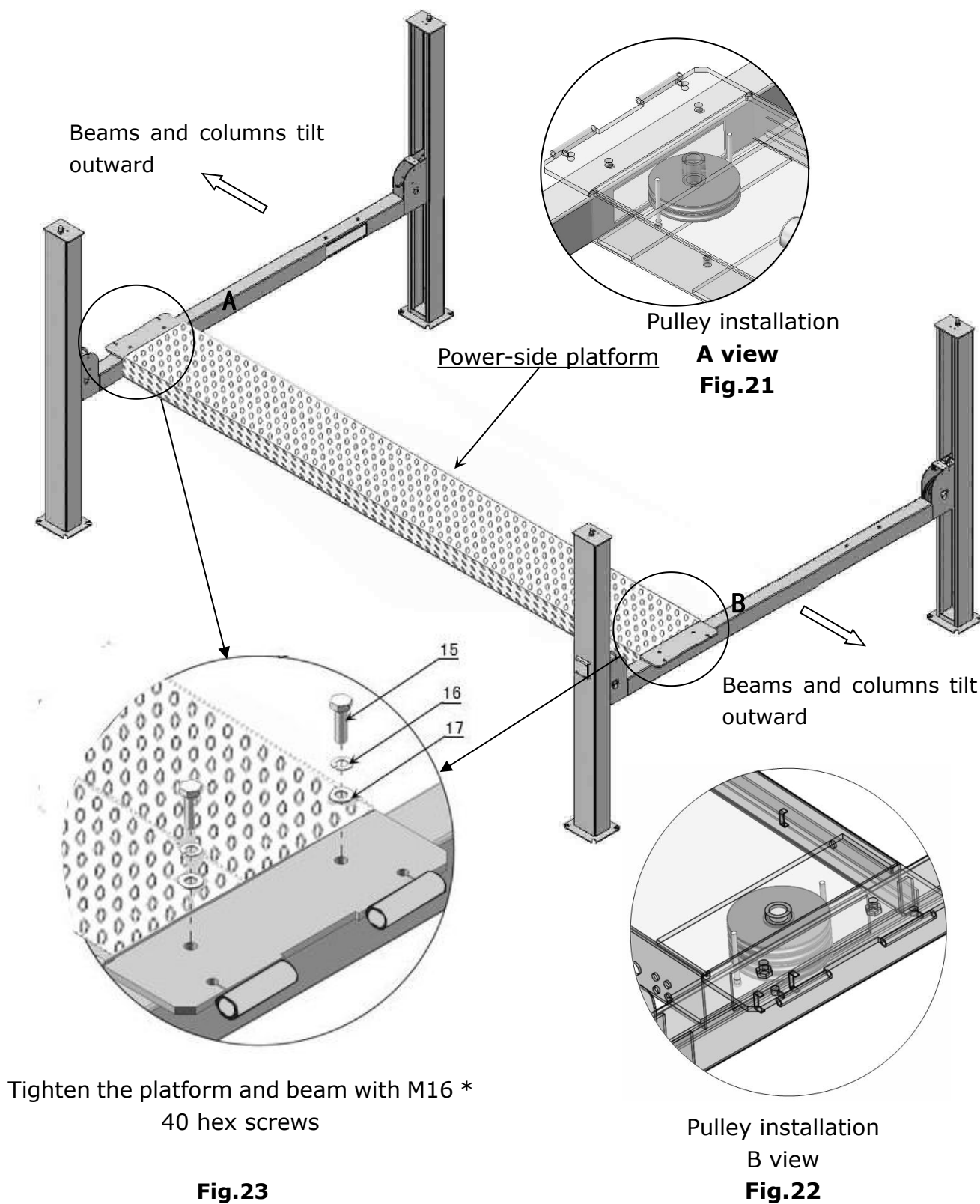

Fig. 20

H. Install power-side platform.

1. Put the power-side platform upon the cross beams by forklift or manual, offset the cross beams to the outside till the pulleys of both platforms can set up into the cross beam (See Fig.21,22), Install the power-side platform and screw up the bolts (See Fig.23).



I. Assembly offside platform and slider block, (See Fig. 24) check the plumbness of columns with level, adjusting with the shims if not, and then tighten the anchor bolts (See Fig. 25).

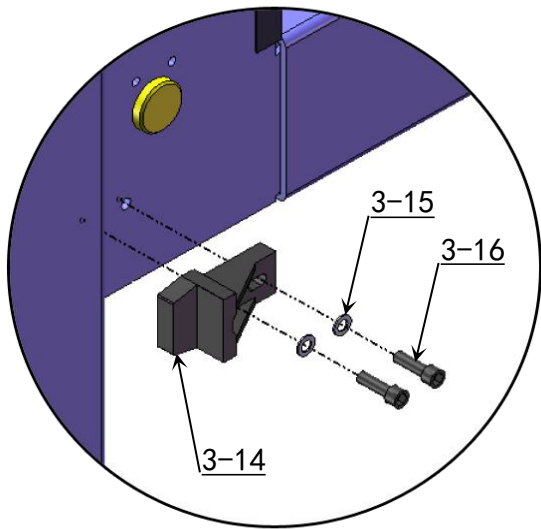
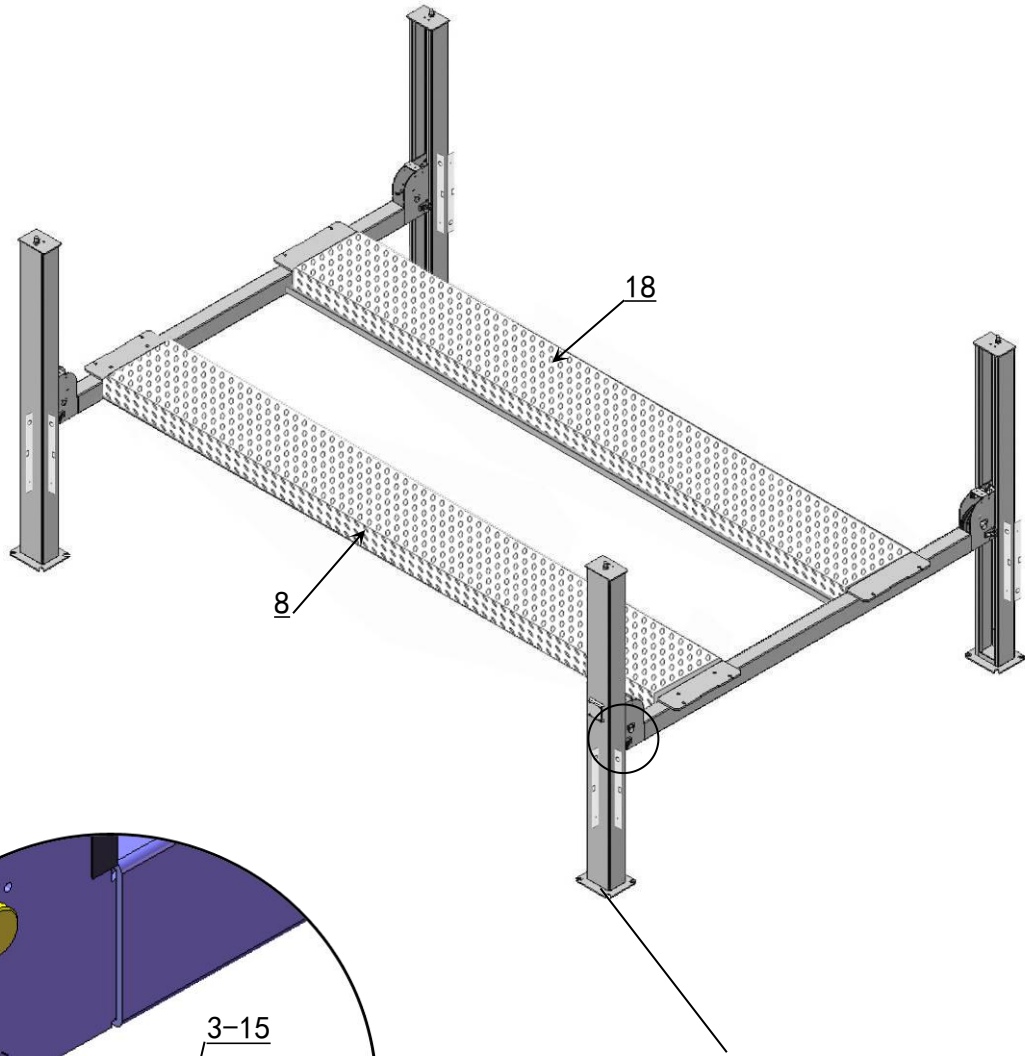

Install the slider block
C View
Fig. 24

Note: Torque of Anchors is 150N.m.

Using the ratchet spanner with socket to tighten the bolts

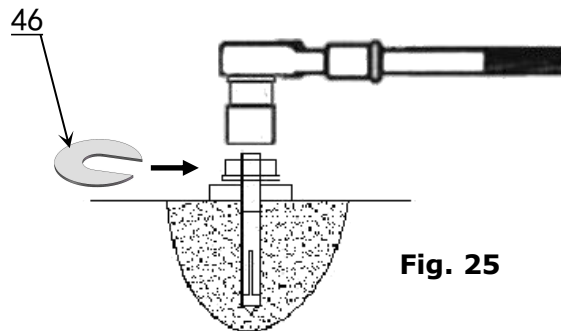

Fig. 25

J. Install cables

1. Pass through the cables from the platform to the columns according to the number of the cables (**See Fig. 26**).

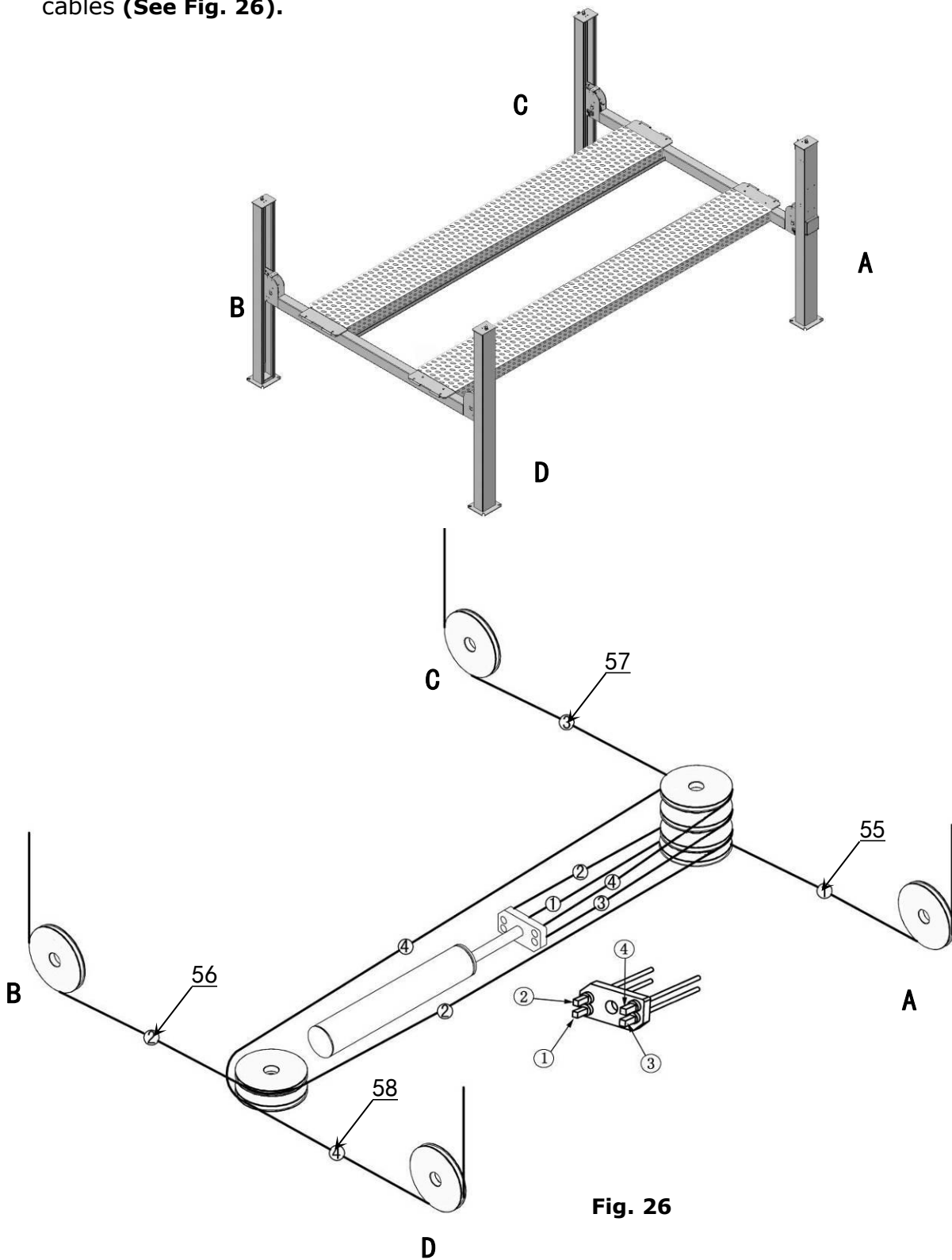
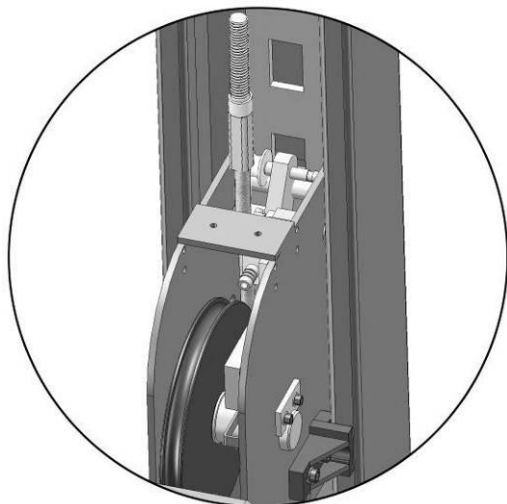

Fig. 26

No. Cable	①	②	③	④	
Length (w/ fitting)	3775mm	10325mm	5380mm	8710mm	KAL-12(A)
Length (w/ fitting)	3850mm	10400mm	5455mm	8785mm	KAL-12AX

2. The cable pass through the cross beam to top plate of columns and be screwed with cable nuts (See Fig. 27, 28), then install the cable limit pin. (See Fig. 29)



Cable pass through between the big pulley and tension pulley

D View
Fig.27

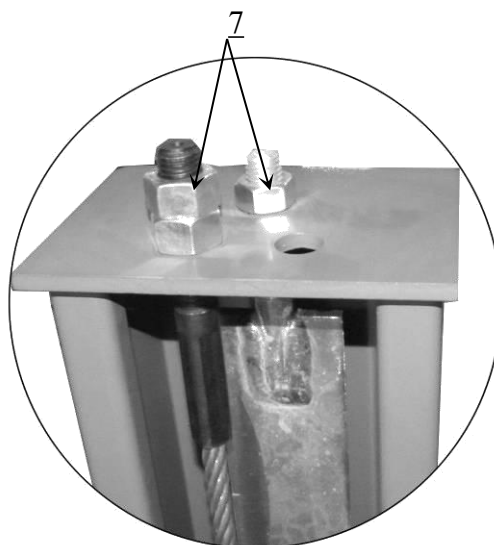

Cable pass through top plate and be screwed with cable nuts.

E View
Fig.28

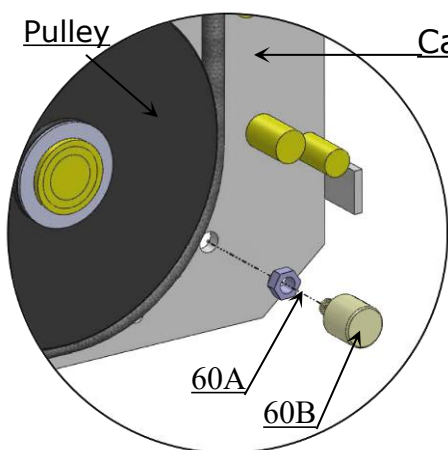
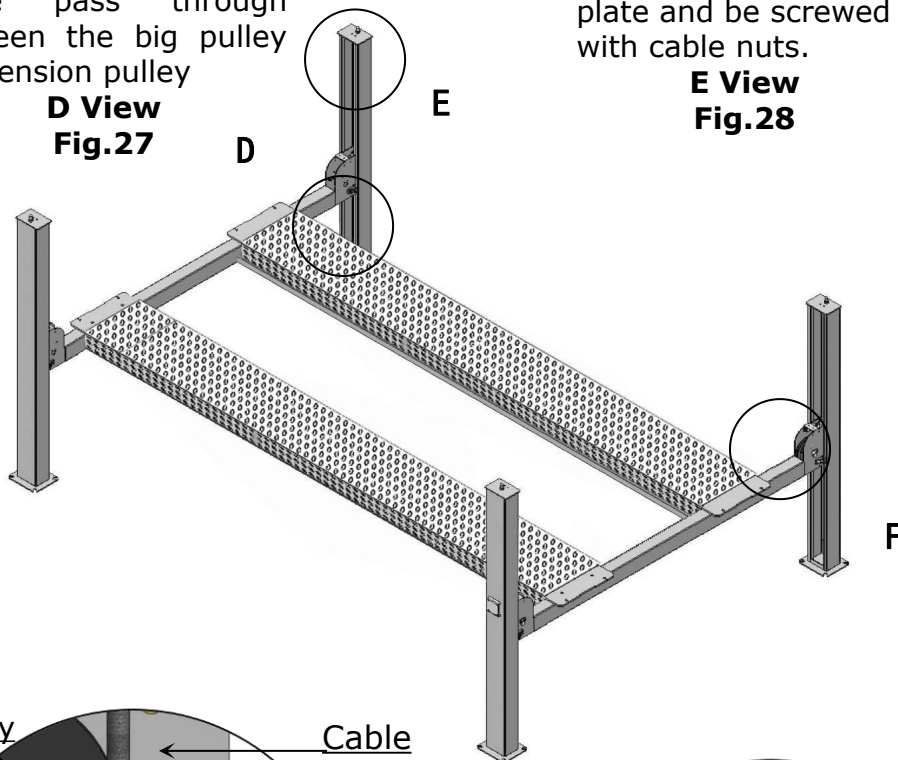

Install limit pin

F View
Fig. 29

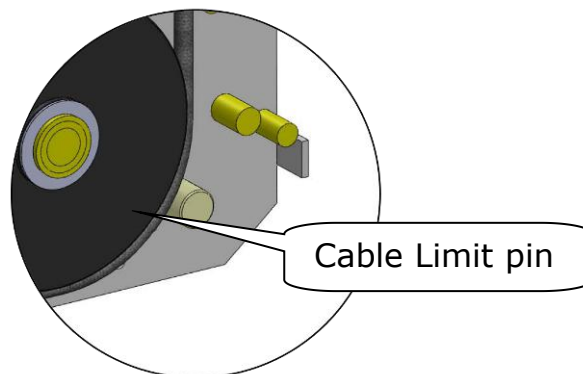

After installation

3. Illustration for platform cables (See Fig. 30, 31, 32).

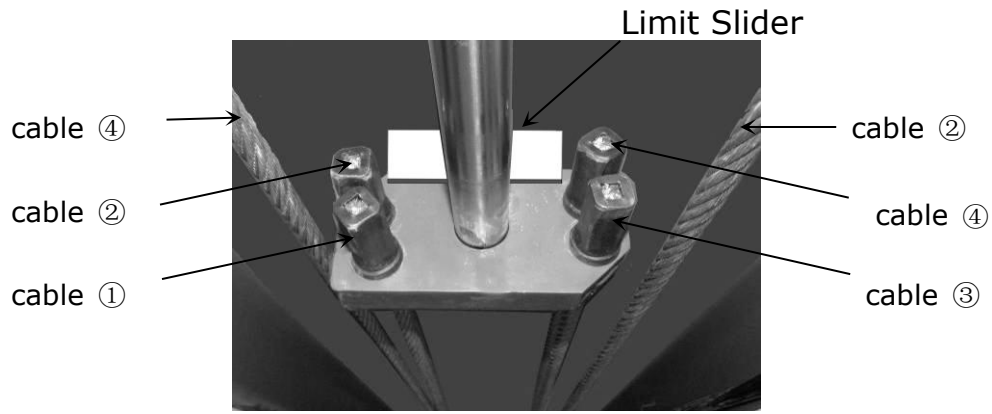

Fig. 30

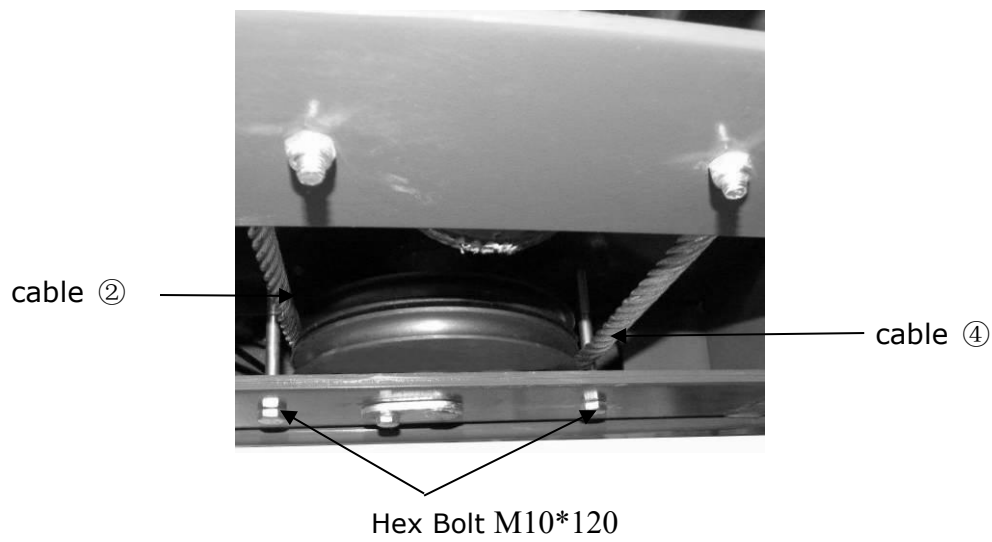
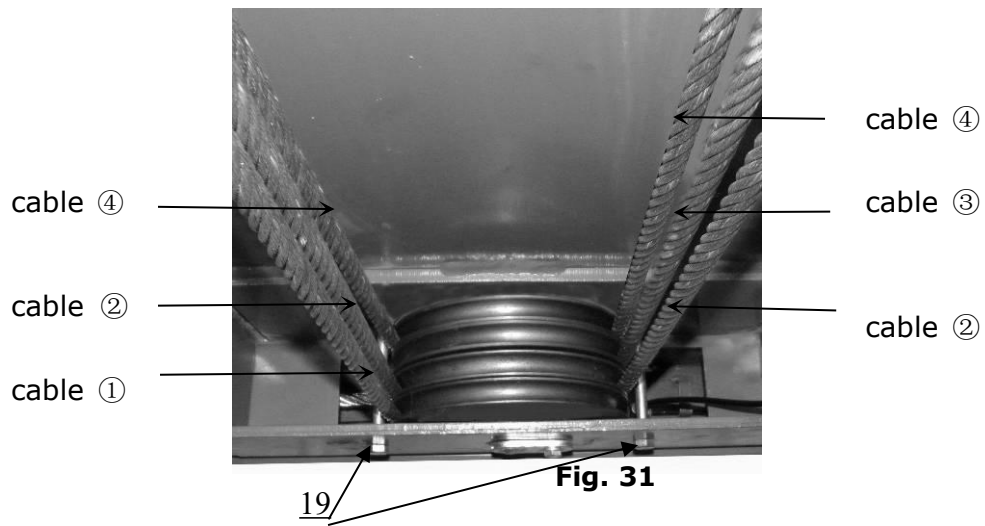

Fig. 32

K. Install oil-water separator, manual control air valve and power unit

(See Fig. 33).

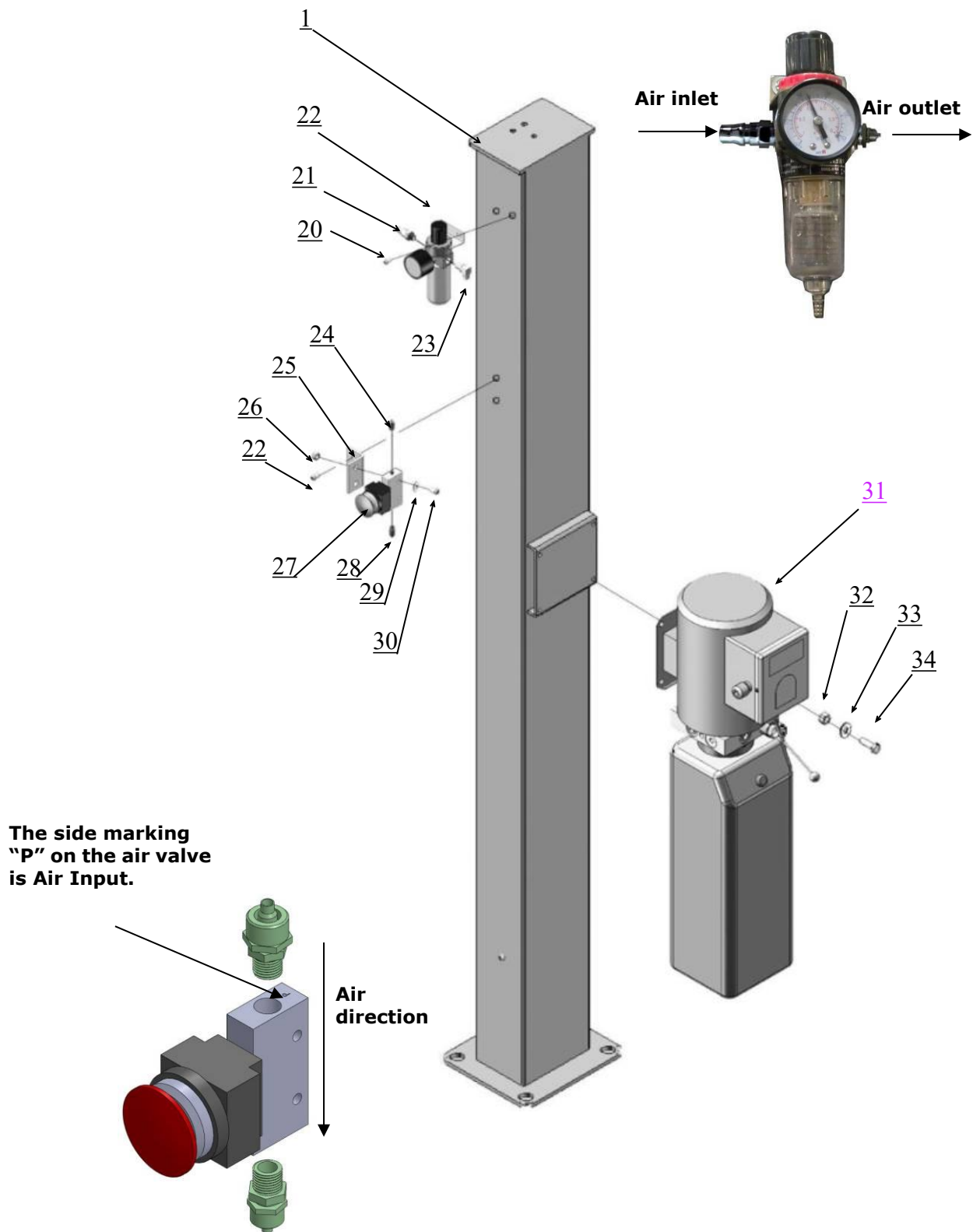
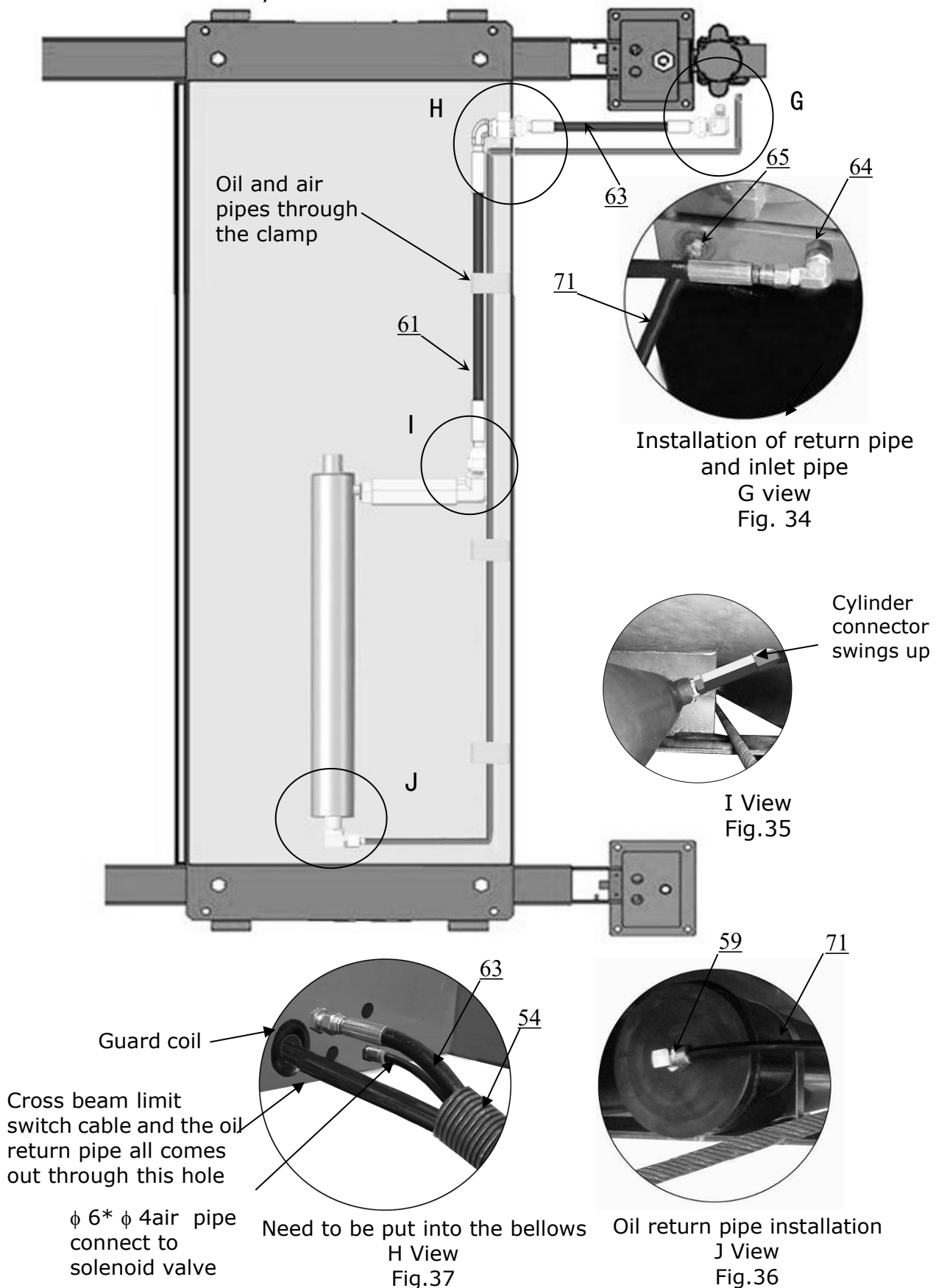

Fig. 33

L. Install hydraulic system.

Note: Oil hoses and oil return pipe connected to oil cylinder must be passed above the cable and cylinder inlet port must swing upward to avoid the oil hose and oil return pipe scratched by cable.



M. Install air-line system

1. Connecting front and rear Cross Beam cylinders by using 6*4 black air pipe. (the actual length of air line can be cut by user) **(See Fig.38)**
2. Cut the 6*4 black air pipe by scissor between two retainers, then connect the air line with T fitting. **(See Fig. 39).**
3. Connecting the solenoid valve using 6*4 black air pipe (the actual length of air line can be cut by user) **(See Fig. 40).**

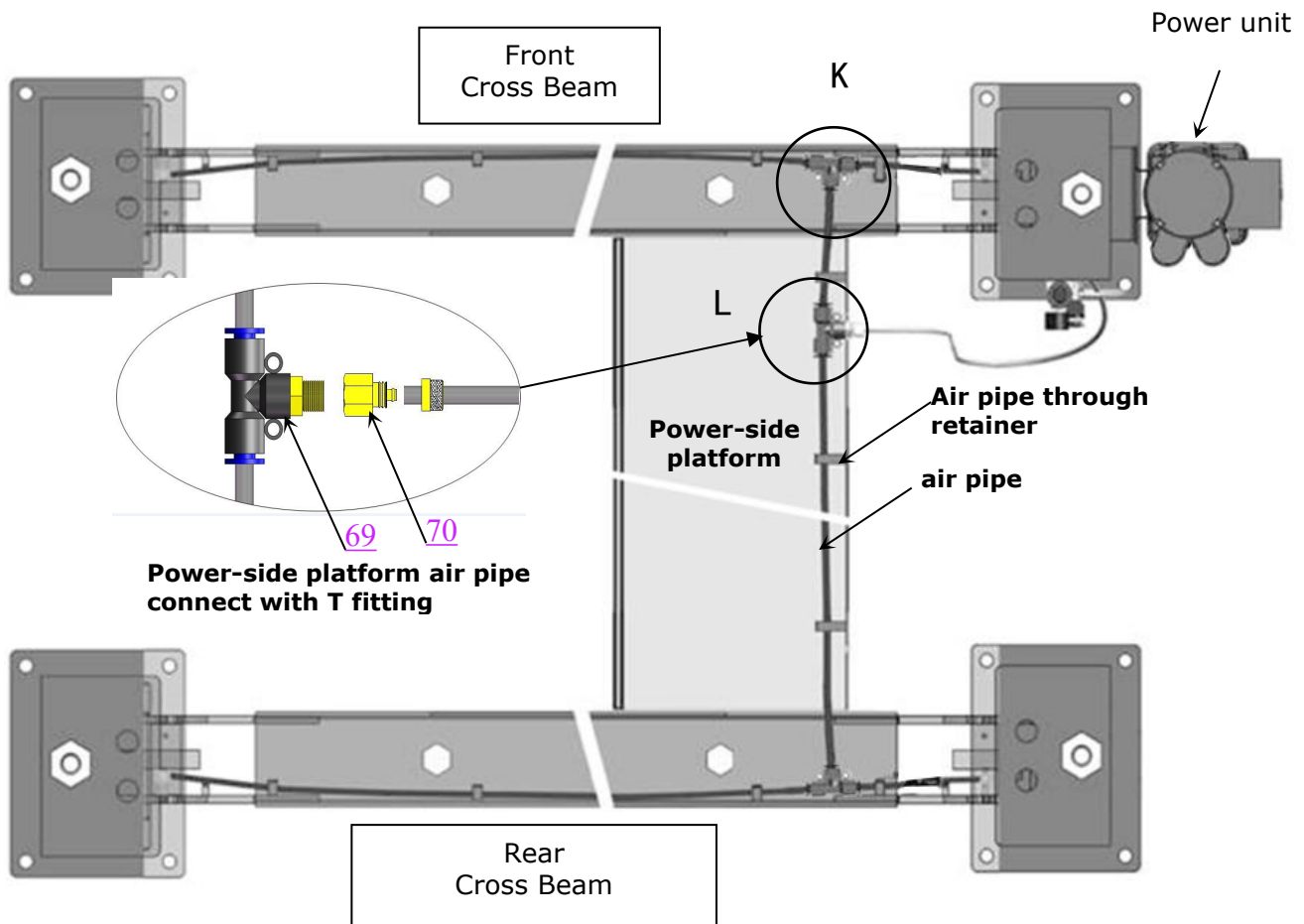
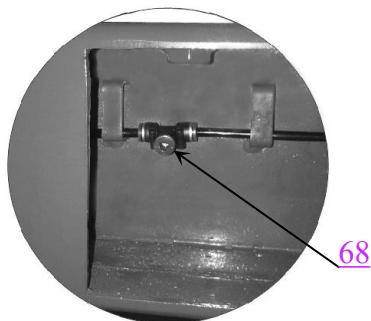
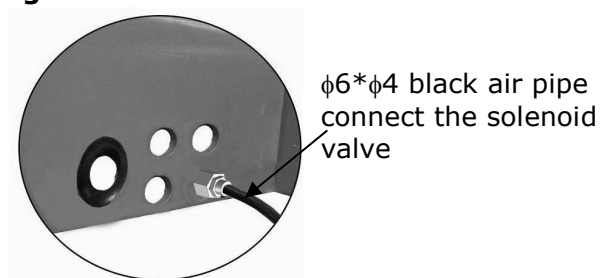

Fig.38



**K view
Fig.39**



**L view
Fig.40**

4. Connecting Oil-water separator and Manual control air valve using air line
(See Fig. 41).

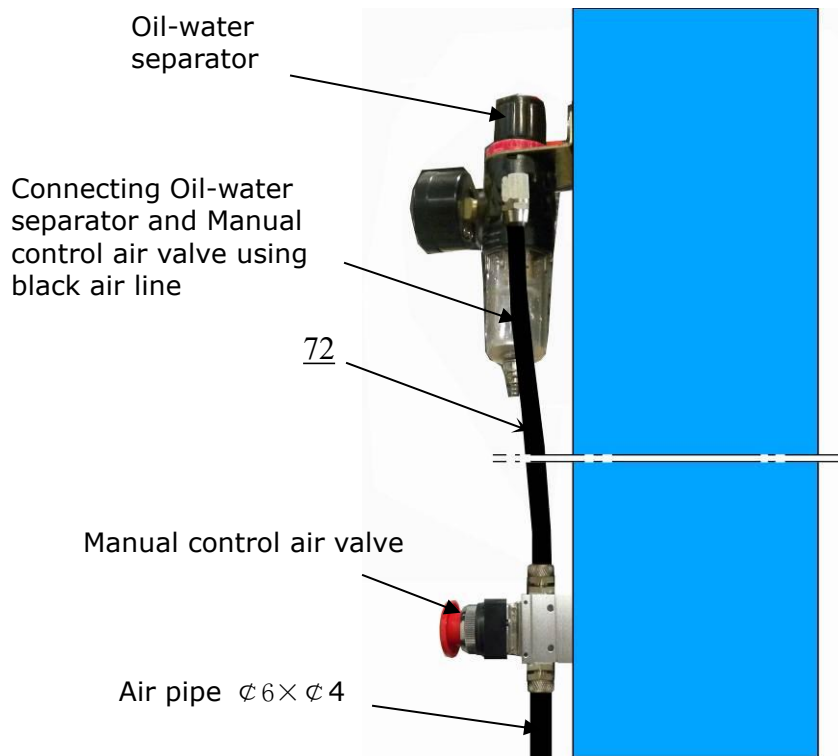

Fig. 41

5. Connecting air inlet (Air supply pressure 8 kg/cm²), adjusting the air pressure of Oil-water separator to 0.8 MPa (See Fig. 42).

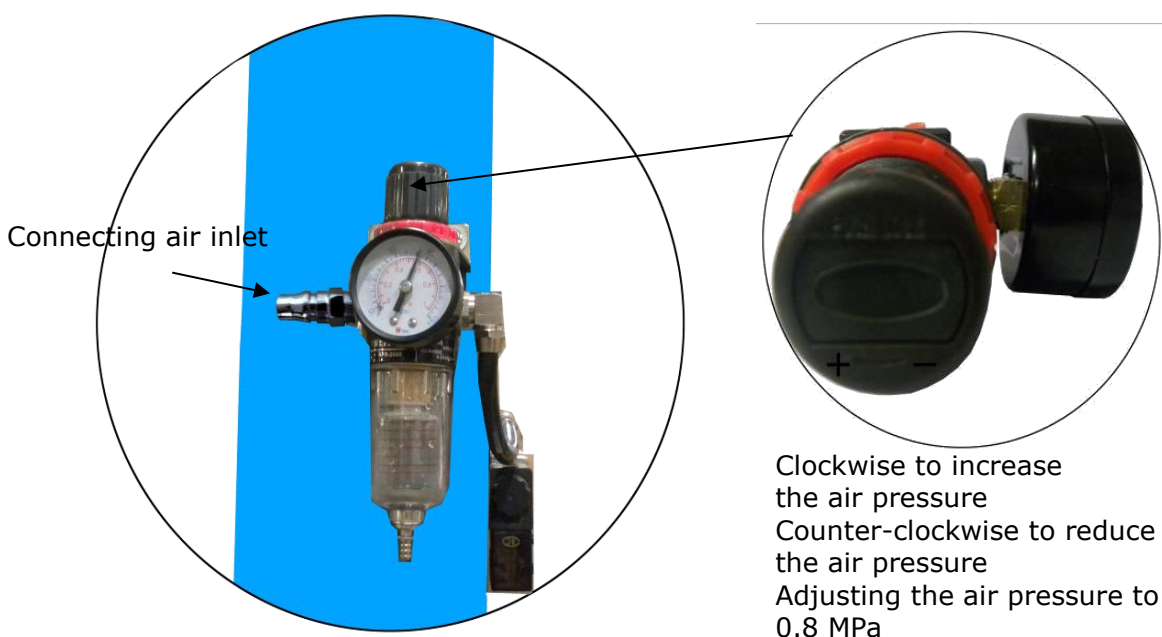

Fig. 42

N. Install Electrical System

Connect the power source on the data plate of Motor.

Note: 1. For the safety of operators, the power wiring must contact the floor well.

2. Pay attention to the direction of rotations when using 380V, three phase motors.

Single phase motor

1. Circuit diagram (See Fig. 43)

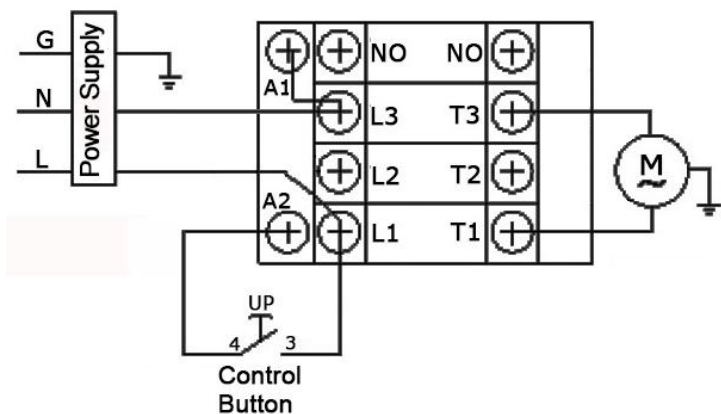
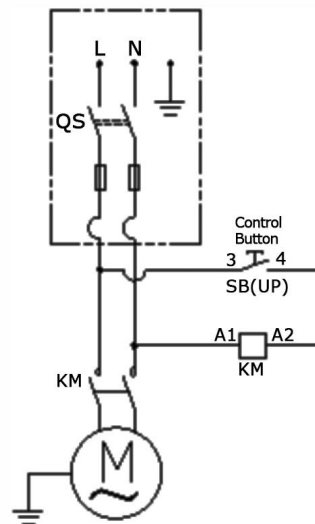

Fig. 43



2. Connection step (See Fig. 44)

Connecting the two power supply wires (active wire **L** and neutral wire **N**) to terminals of AC contactor marked **L1, L3** respectively. Earth wire (yellow and green wire) is connected with the earth wire terminal of the motor

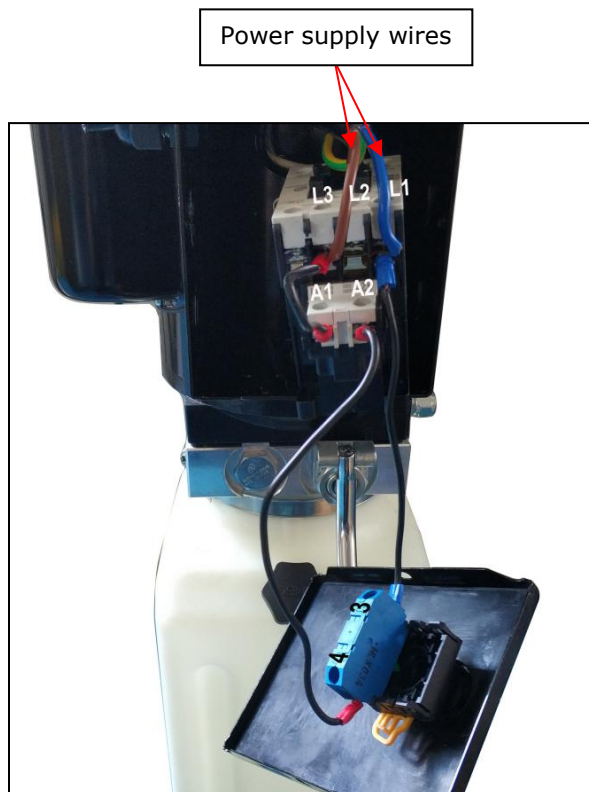

Fig. 44

Three phase motor

The power supply wires **L1, L2, L3** are connected with terminals of AC contactor marked **L1, L2, L3** respectively. Earth wire(yellow and green wire) is connected with the earth wire terminal of the motor.(See Fig. 45)

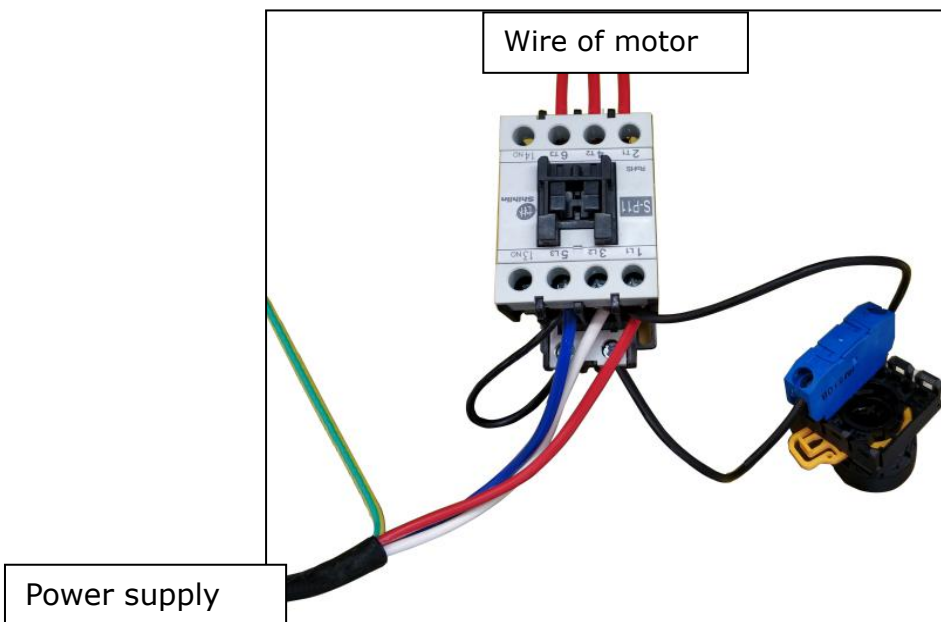
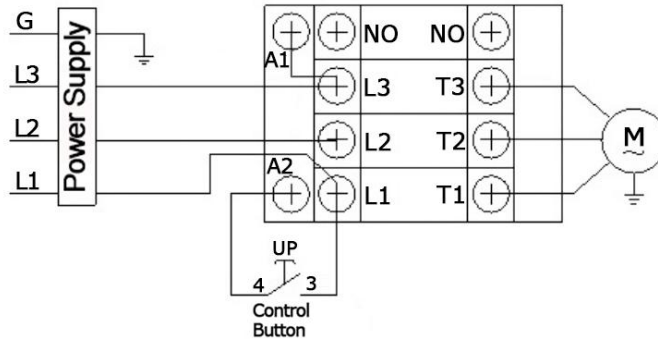

Fig. 45

O. Install spring and safety cover of cross beam (See Fig. 46).

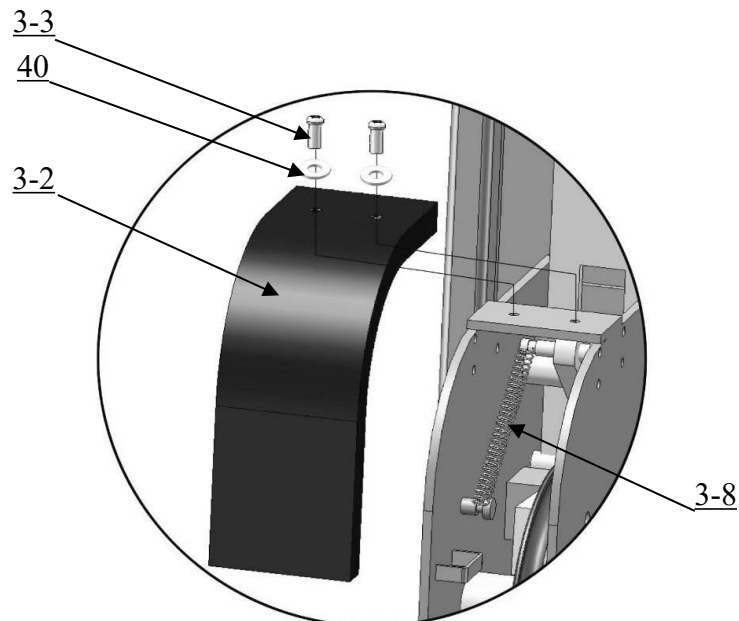
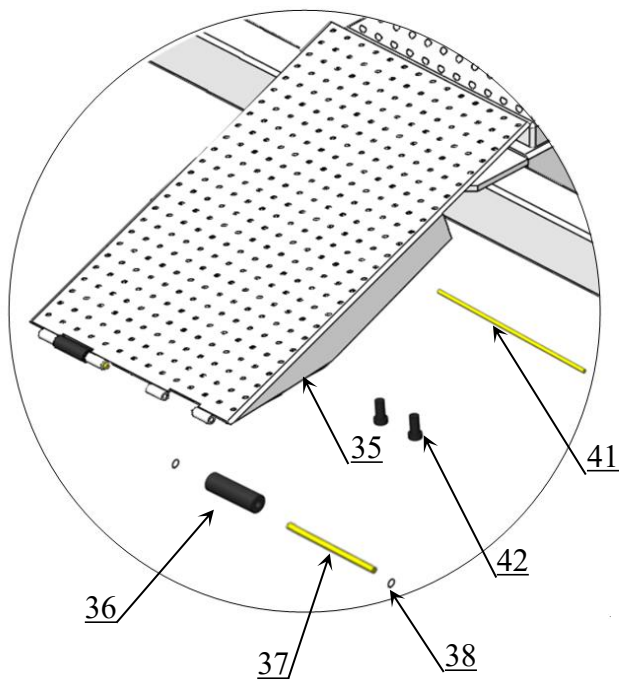

Fig. 46

P. Install drive-in ramp, tire stop plate, platform lock plates, Limit rod (See Fig. 47)

Install Drive-in ramp



Install Tire stop plate

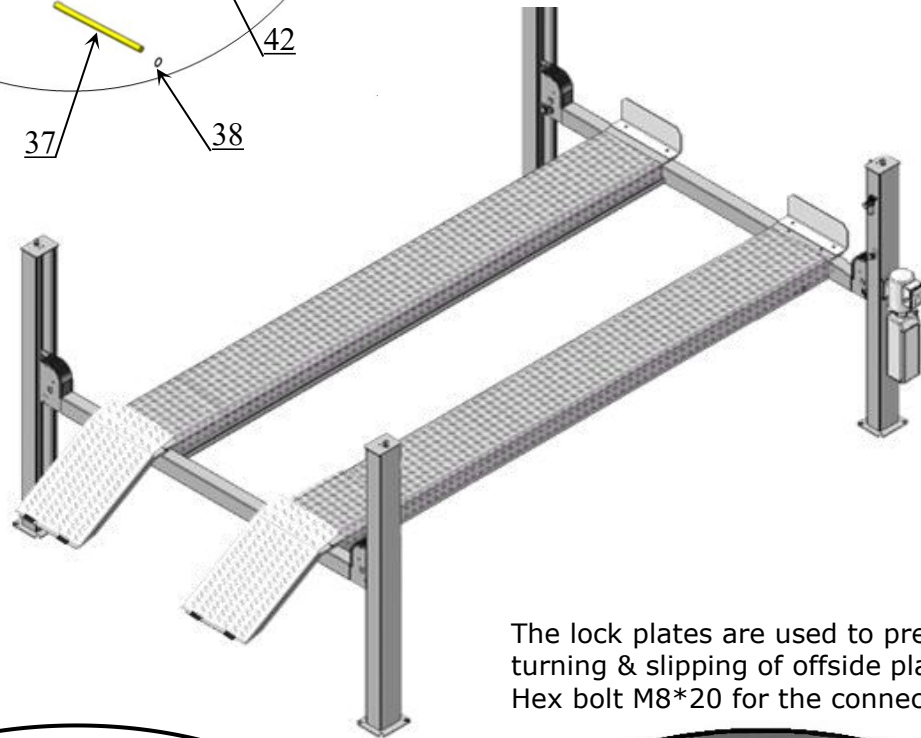
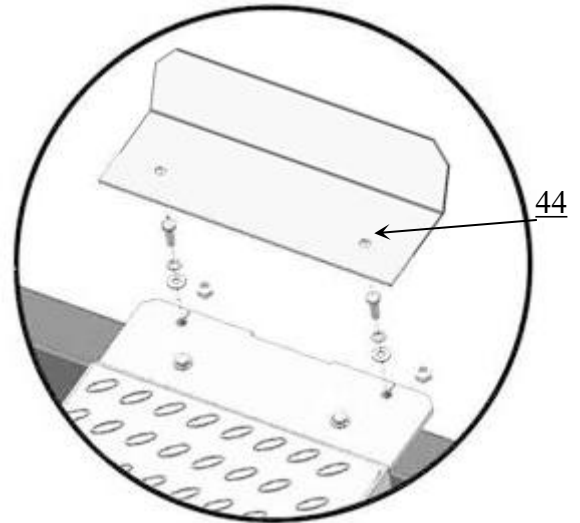

The lock plates are used to prevent the turning & slipping of offside platform, Using Hex bolt M8*20 for the connection.

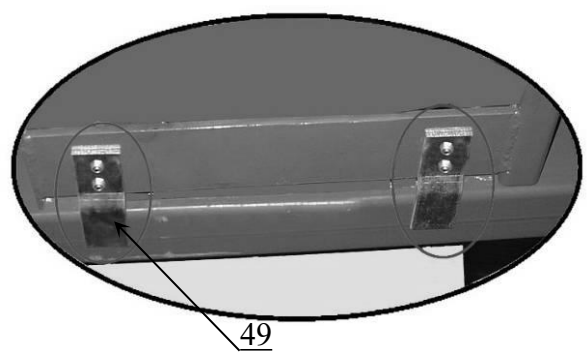
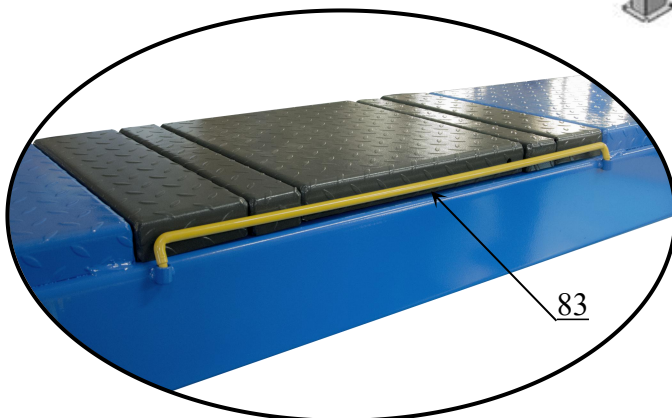

Install Limit rod

Fig.47

IV. EXPLODED VIEW

KAL-12

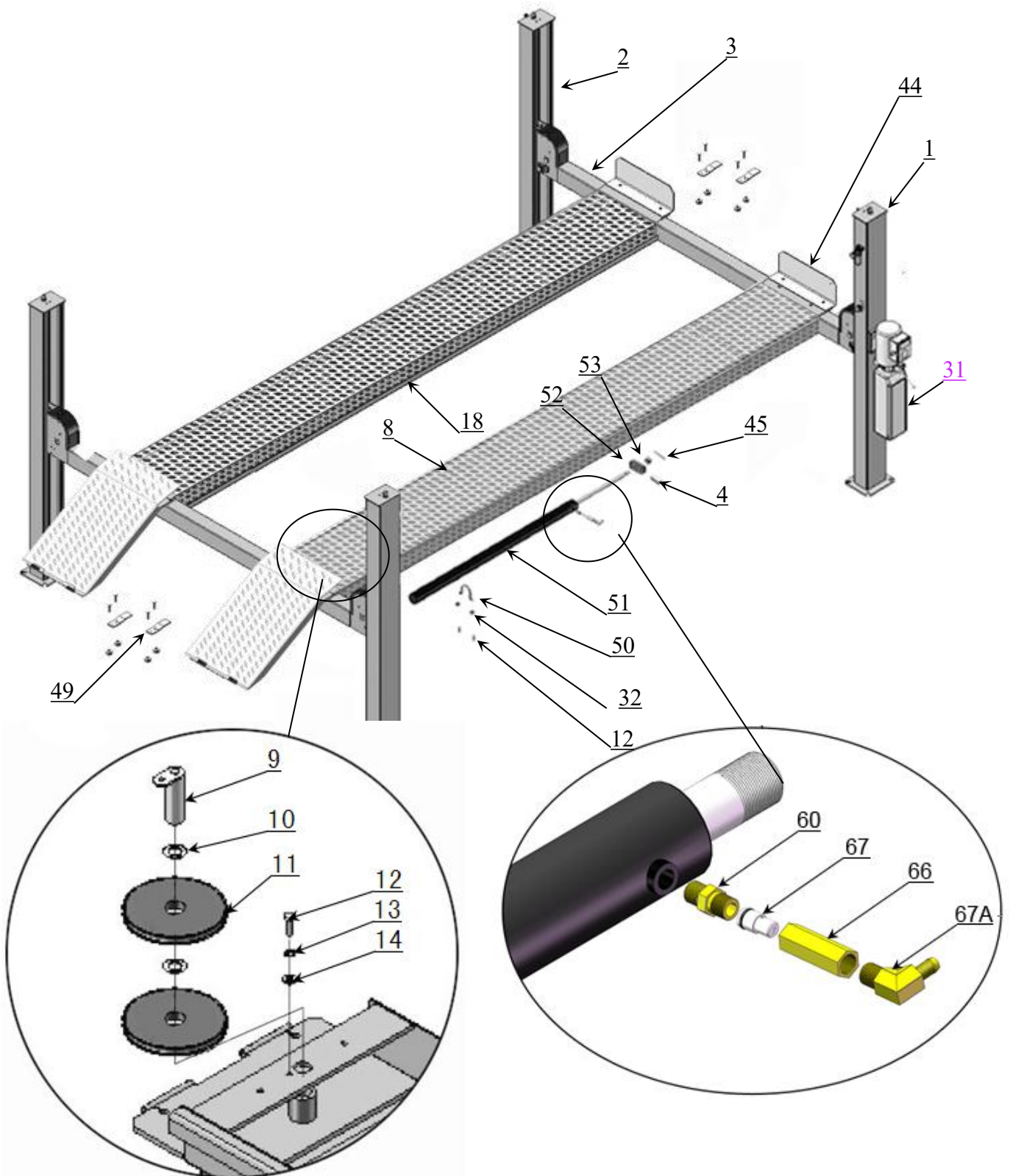
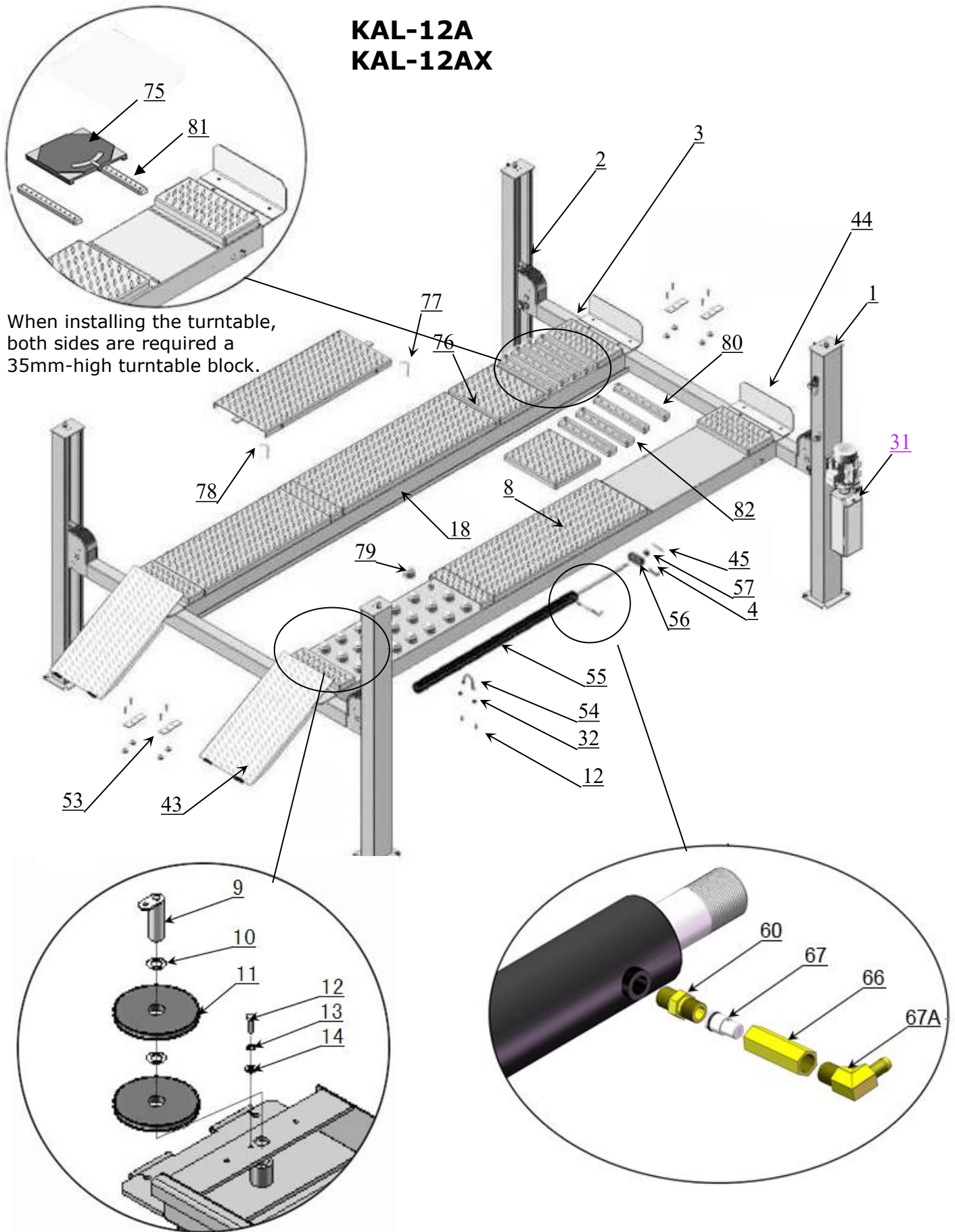

Fig.48

**KAL-12A
KAL-12AX**



When installing the turntable, both sides are required a 35mm-high turntable block.

Fig.49

PARTS LIST FOR KAL-12, KAL-12A, KAL-12AX

Item	Part#	Description	KAL-12	KAL-12A	KAL-12AX
1	11420011A	Power-side Column	1	1	1
2	11420002	Offside Column	3	3	3
3	10420253	Cross Beam Assy.	2	2	0
	10480040		0	0	2
4	10440041	Slider block	1	1	1
5	10209059	Anchor Bolt	16	16	16
6	11410022	Safety Ladder	4	4	4
7	10420175A	Hex Nut	16	16	16
8	11440038	Power-side Platform	1	0	0
	11440002A		0	1	1
9	11420022A	Pulley Shaft Weldment	2	2	2
10	10476029	Washer	4	4	4
11	11476636	Pulley	6	6	6
11A	10476025	Bronze Bush for Pulley	6	6	6
11B	10420132A	Bronze Bush	4	4	4
12	10209043	Hex Bolt	12	12	12
13	10209034	Lock Washer	2	2	2
14	10420144	Washer	2	2	2
15	10420030	Hex Bolt	12	12	12
16	10420137	Lock Washer	12	12	12
17	10420029	Washer	12	12	12
18	11440039	Offside Platform	1	0	0
	11440001		0	1	1
19	10600015	Hex Bolt	4	4	4
20	10420145	Oil-water Separator	1	1	1
21	10420146	Straight Fitting for Air Line	1	1	1
22	10209009	Cup Head Bolt	4	4	4
23	10420076	90° Fitting for Air Line	1	1	1
24	10420159	Straight Fitting for Air Line	1	1	1
25	11420160	Fixing plate of Manual Control Valve	1	1	1
26	10420161	Self-locking Nut	2	2	2
27	10420162	Manual Control Air Valve	1	1	1
28	10420163	Straight Fitting for Air Line	1	1	1
29	10420148	Washer	4	4	4
30	10420164	Cup Head Bolt	2	2	2
203	81513001/81513002	Manual Power Unit	1	1	1
32	10209005	Self-locking Nut	14	14	14
33	10209004	Rubber Ring	4	4	4
34	10209003	Hex Bolt	4	4	4
35	11420003	Drive-in Ramp assy.	2	0	0
	11430002		0	2	2
36	11610667	Drive-in Ramp pulley	4	4	4
37	11610667	Drive-in Ramp pulley pin	4	4	4
38	10209010	Snap ring	8	8	8
39	10420156	Protecting Ring	1	1	1
40	10420045	Washer	20	20	20
41	11420004	Pin for Drive-in Ramp	2	2	2
42	10420005	Fixing Bolt	4	4	4

43	10440501	Part box	1	0	0
	10450501		0	1	1
44	11420031-1	Tire stop plate	2	2	2
45	10201005	Split pin	1	1	1
46	10620065	Shim 1mm	20	20	20
	10201090	Shim 2mm	20	20	20
47	10209056	Self-locking Nut	4	4	4
48	11420217	Cable limit pin	4	4	4
49	11420007	Plate for Adjustable Turnplate	4	4	4
50	11420012A	Cylinder fixing ring	1	1	1
51	10420012	Cylinder	1	1	1
52	11430622	Cable connecting plate	1	1	1
53	10420014	Hex nut	1	1	1
54	10420016B	Protective hose	1	1	1
55	10440078	No.① Cable	1	1	0
	10450005		0	0	1
56	10440081	No.② Cable	1	1	0
	10450008		0	0	1
57	10440079	No.③ Cable	1	1	0
	10450006		0	0	1
58	10440080	No.④ Cable	1	1	0
	10450007		0	0	1
59	10420166	90° Fitting	1	1	1
60	10420243	Straight Fitting for Cylinder	1	1	1
61	10440042	Oil Hose	1	1	1
62	10420120	Extended Straight Fitting (with Nut)	1	1	1
63	10207026	Oil Hose	1	1	1
64	10209060	90° Fitting	1	1	1
65	10420095	Straight Fitting for Power Unit	1	1	1
66	10420245	Straight Fitting	1	1	1
67	10420247	compensation Valve	1	1	1
67A	10201020	90° Fitting	1	1	1
68	10420124	T-Fitting for Air Line	2	2	2
69	10420242	T-Fitting for Air Line	1	1	1
70	10420241	Straight Fitting for Air Line	1	1	1
71	10420195A	Oil Return Hose	1	1	1
71A	10420131B	Black Air Line	1	1	1
72	10420167A	Black Air Line	1	1	1
73	11476635	Pulley	4	4	4
74	10476024	Pulley washer	8	8	8
75	1040101	Tureplate	0	2	2
76	11430004	Cover for Tureplate	0	2	2
77	11520037	Pin	0	4	4
78	11450003	Side slide plate	0	2	2
79	10420157	Positioning ball set	0	60	60
80	11480033	Turntable adjusting block	0	4	4
81	11480045	Turntable adjusting block	0	4	4
82	11480082	Turntable adjusting block	0	4	4
83	11440090	Limit rod	0	4	4

4.1 CROSS BEAM

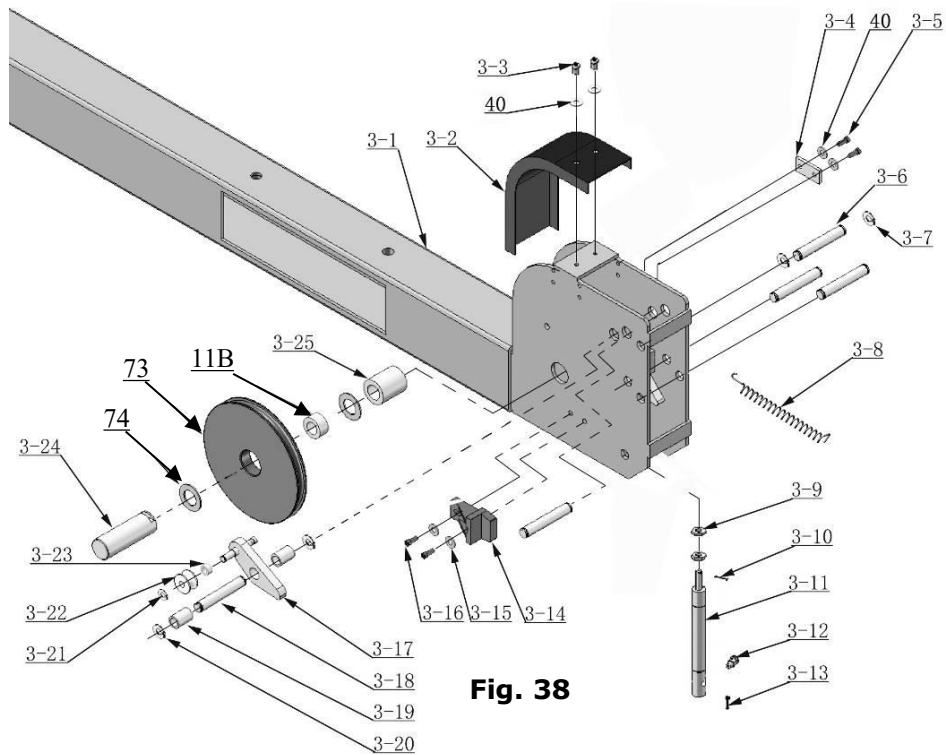

Fig. 38

Fig. 50

Parts list for Cross Beam				
Item	Part#	Description	Qty	Note
3-1	11420254	Cross Beam KAL-12(A)	2	
	11480023	Cross Beam KAL-12AX	2	
3-2	10420051B	Pulley Safety Cover	4	
3-3	10209009	Cup Head Bolt	8	
3-4	11420044	Limit Plate	4	
3-5	10420138	Socket Bolt	8	
3-6	11420038	Pin	12	
3-7	10420037	Snap Ring	24	
3-8	10420033	Spring	4	
3-9	10209021	Hex Nut	8	
3-10	10420049	Split Pin	4	
3-11	10420048	Air Cylinder	4	
3-12	10420047	Fitting for Air Cylinder	4	
3-13	10420046	Split Pin	8	
3-14	10420042	Slider block	8	
3-15	10209033	Washer	24	
3-16	10420043	Socket Bolt	16	
3-17	11420175	Slack-cable safety lock (left & right)	2/2	
3-18	11420171	Pin	8	
3-19	11420172	Pin Bush for Slack-cable safety lock	8	
3-20	10206019	Snap Ring	16	
3-21	10209010	Snap Ring	4	
3-22	10420035	Tension Pulley	4	
3-23	11420174	Spacer	4	
3-24	11420041A	Pulley Pin	4	
3-25	11420040A	Pulley Bush	4	

4.2 CYLINDERS

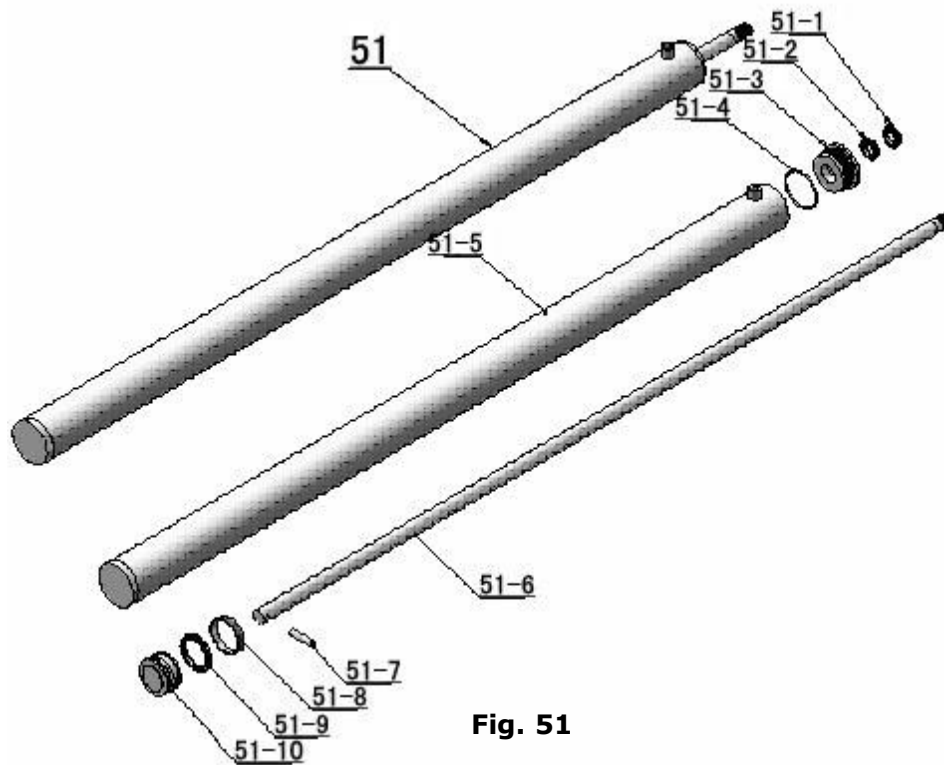

Fig. 51

Parts list for Cylinder				
Item	Part#	Description	Qty	Note
51-1	10420059	Dust Ring	1	
51-2	10420060	Y- Ring	1	
51-3	11420061	Head Cap	1	
51-4	10420062	O- Ring	1	
51-5	11420063	Bore Weldment	1	
51-6	11420064	Piston Rod	1	
51-7	11420065	Pin	1	
51-8	10420066	Support Ring	1	
51-9	10420067	Y- Ring	1	
51-10	11420068	Piston	1	

4.3 Power unit (071102) exploded view:

220V/60HZ, Single Phase

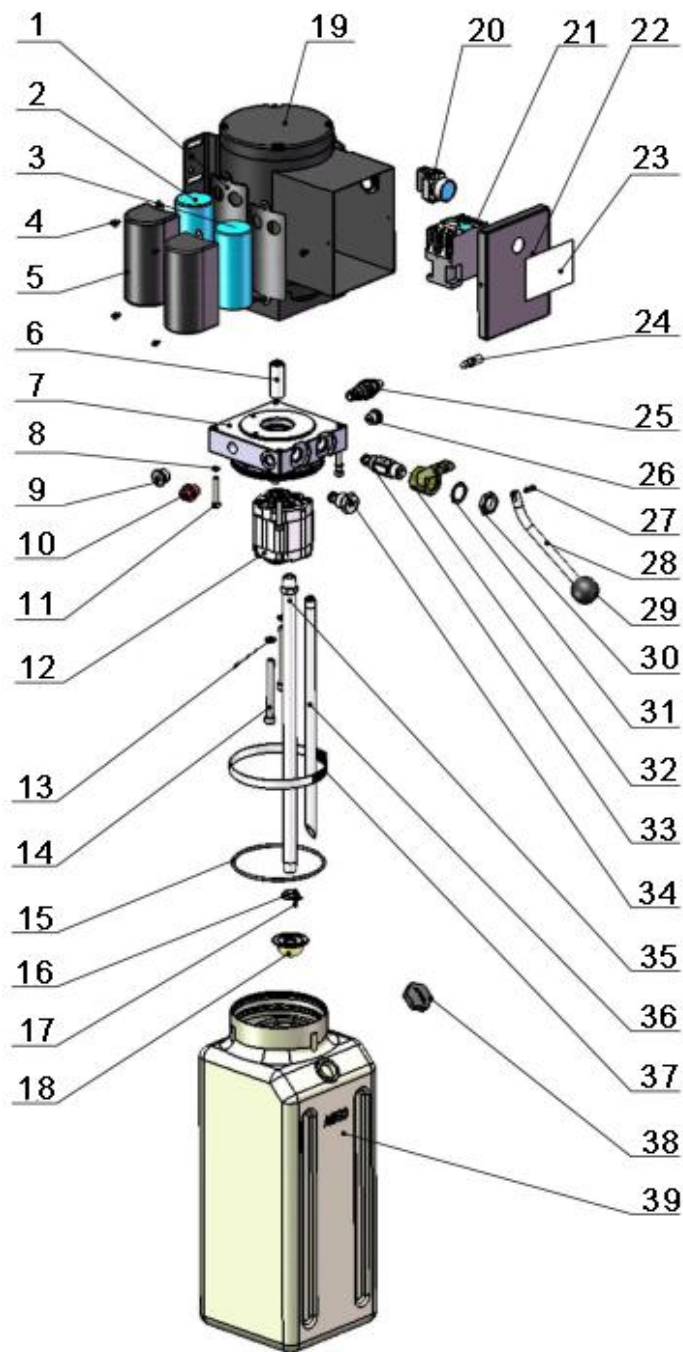

Fig.52

Parts list for 220V/50Hz, Single Phase

Item	Part#	Description	Qty
1	81400180	Rubber Pad	2
2	81400250	Starting capacitor	1
3	81400200	Running capacitor	1
4	10420148	Cap Head Bolt with washer	4
5	81400066	Cover of Motor Terminal Box	2
6	81400363	Motor Connecting Shaft	1
7	80101013	Manifold block	1
8	10209149	Washer	4
9	81400276	Iron plug	1
10	81400259	Red rubber plug	1
11	85090142	Socket bolt	4
12	81400280	Gear pump	1
13	10209034	Washer	2
14	81400295	Socket bolt	2
15	81400365	O ring	1
16	10209152	Ties	1
17	85090167	Magnet	1
18	81400290	Filter net	1
19	81400413	Steel Motor	1
20	10420070	Push button	1
21	41030055	AC connector	1
22	81400287	Motor terminal box cover	1
23	71111216	AMGO power unit label	1
24	81400560	Throttle valve	1
25	81400266	Relief valve	1
26	81400284	Inner hex iron plug	1
27	10720118	Hair pin	1
28	81400451	Release valve handle	1
29	10209020	Plastic ball for release handle	1
30	81400421	Release valve nut	1
31	81400422	Shim	1
32	81400449	Valve Seat(Low)	1
33	81400567	Release Valve	1
34	81400566	Check Valve	1
35	81400366	Oil suction pipe	1
36	81400289	Oil return pipe	1
37	81400364	Clamp(stainless steel)	1
38	81400263	Oil tank cap	1
39	81400319	Oil tank	1

Illustration of hydraulic valve for power unit

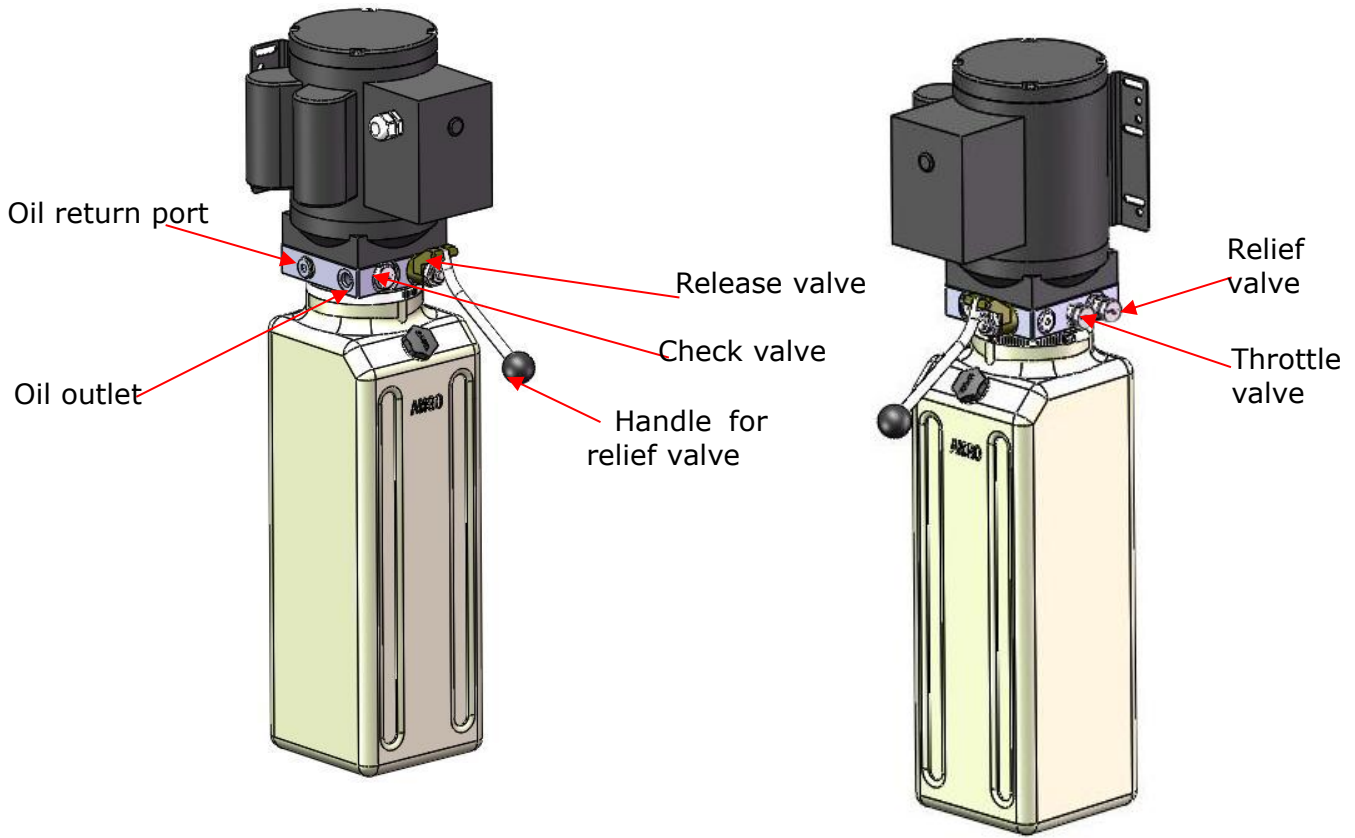

Fig.53

V. TEST RUN

1. Fill the reservoir with approximately 14L Hydraulic Oil (**Note:** In consideration of Power Unit's durability, please use **Hydraulic Oil 46#**).
2. Press button **UP**, the Cables will be strained. Check whether the Cables match the Pulley. Make sure the Cables are not across.
3. Press the Handle of release valve to lock the Cross-beam to the safety ladders, and then adjust the platforms to be level by adjusting the nuts of Safety Ladders.
4. Adjust the cable fitting Hex nuts to make platforms and four safety locks work synchronously. You need to run the lift up and down for several times, meanwhile do the synchronous adjustment till the four Safety Devices can lock and release at the same time.
5. Adjust the clearance between the post and the plastic slider of Cross-beam to about 2mm, and then tighten the fixing nut of slider.
6. After finishing the above adjustment, test running the lift with load. Run the lift with Platforms in low position first, make sure the Platforms can rise and lower synchronously and the Safety Device can lock and release synchronously. And then test run the lift to the top completely. If there are anything improper, repeat the above adjustment.

Circuit Diagram of Hydraulic System

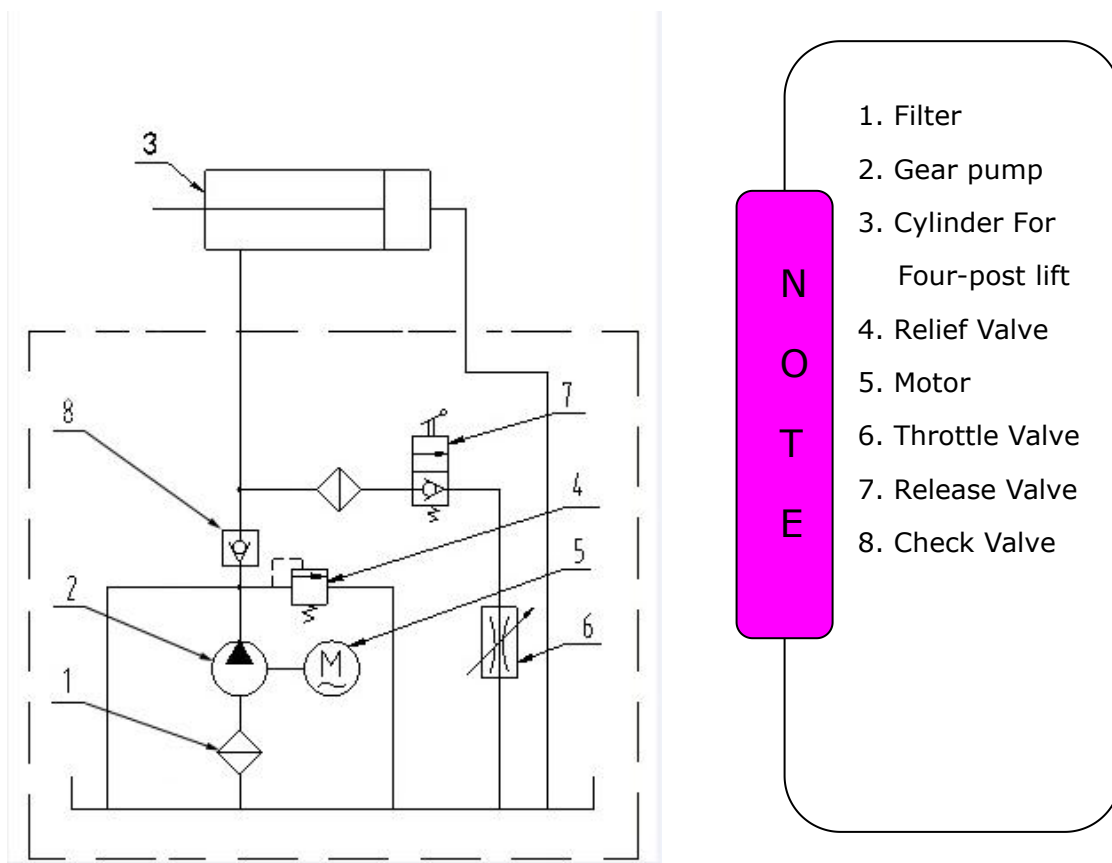

Fig. 54

VI. OPERATION INSTRUCTIONS

To lift vehicle

1. Keep clean of environment near the lift;
2. Drive vehicle to the Platform and put on the brake;
3. Turn on the power and press the button **UP**, raise the lift to the working position;
Note: make sure the vehicle is steady when the lift is raised.
4. Press the Handle of release valve to lock the lift in the safety position. Make sure the Safety device is locked at the same height.

To lower vehicle

1. Be sure the clearance of around and under the lift, only leaving operator in lift area;
2. Press the button **UP**, the lift will be raised for 3-5 seconds, and then press the button of Manual-controlled air valve by hand to make sure the safety device released, press the handle of release valve by the other hand then the lift starts being lowered automatically;
3. Drive away the vehicle when the lift is lowered to the lowest position.
4. Turn off the power.

VII. MAINTENANCE SCHEDULE

Monthly:

1. Re-torque the anchor bolts to 150 Nm;
2. Lubricate cable with lubricant;
3. Check all cable connection, bolts and pins to insure proper mounting;
4. Make a visual inspection of all hydraulic hoses/lines for possible wear or leakage;
5. Lubricate all Rollers, Safety devices with 90wt. gear oil or equivalent.

Note: All anchor bolts should take full torque. If any of the bolts does not function for any reason, DO NOT use the lift until the bolt has been replaced.

Every six months:

1. Make a visual inspection of all moving parts for possible wear, interference or damage.
2. Check and adjust as necessary, equalizer tension to insure level lifting.
3. Check columns for plumbness.

Oil cylinder maintenance:

In order to extend the service life of the oil cylinder, please operate according to the following requirements.

1. Recommend to use N46 anti-wear hydraulic oil.
2. The hydraulic oil of the lifts should be replaced regularly during using.
Replace the hydraulic oil 3 months after the first installation, Replace the hydraulic oil once a year afterwards.
3. Make at least one full trip raising and lowering per day. For exhausting the air from the system, which could effectively avoid the corrosion of the cylinder and damage to the seals caused by presence of air or water in the system.
4. Protect the outer surface of the oil cylinder's piston rod from bumping and scratching, and timely clean up the debris on the oil cylinder dust-ring and the piston rod.

VIII. TROUBLE SHOOTING

TROUBLE	CAUSE	REMEDY
Motor does not run	<ol style="list-style-type: none"> 1. Button does not work 2. Wiring connections are not in good condition 3. Motor burned out 4. AC contactor burned out 5. Height limit switch is damaged 	<ol style="list-style-type: none"> 1. Replace button 2. Repair all wiring connections 3. Repair or replace motor 4. Replace AC contactor 5. Replace
Motor runs but the lift is not raised	<ol style="list-style-type: none"> 1. Motor runs in reverse rotation 2. Release valve in damage 3. Gear pump in damage 4. Relief valve or check valve in damage 5. Low oil level 	<ol style="list-style-type: none"> 1. Reverse two power wire 2. Repair or replace 3. Repair or replace 4. Repair or replace 5. Fill tank
Lift does not stay up	<ol style="list-style-type: none"> 1. Release valve out of work 2. Relief valve or check valve leakage. 3. Cylinder or fittings leaks 	Repair or replace
Lift raises too slow	<ol style="list-style-type: none"> 1. Oil line is jammed 2. Motor running on low voltage 3. Oil mixed with Air 4. Pump leaks 5. Overload lifting 	<ol style="list-style-type: none"> 1. Clean the oil line 2. Check electrical system 3. Fill tank 4. Replace Pump 5. Check load
Lift cannot lower	<ol style="list-style-type: none"> 1. Safety device are in activated 2. Release valve damaged 3. Air Cylinder damaged 4. Oil system is jammed 	<ol style="list-style-type: none"> 1. Release the safeties 2. Replace or repair 3. Replace the cylinder 4. Clean the oil system

IX. LIFT DISPOSAL:

When the car lift cannot meet the requirements for normal use and needs to be disposed, it should follow local laws and regulations.



PEAK CORPORATION

No. 3 Luomu Road, Shishan Town, Nanhai District, Foshan(528225), Guangdong, China

Tel:86-757-81102815 81102805

Fax: 86-757-81102809

Email:peak@peaklift.cn <http://www.peaklift.cn>

Manual Part No.: 72204409

Revision Date: 2022/03