



Original

Installation And Service Manual

FOUR POST PARKING LIFT

MODEL: 409-DP 409-DPX

Cargo Claims

If there is any missing or damage of the cargo during transportation, the buyer should claim on the carrier, since the invoices issued by the carrier is made out to the buyer.

DANGER

Read the entire contents of this manual **before** using this product. Failure to follow instructions and safety precautions could result in serious injury or even death. Make sure all other operators also read this manual. Keep this manual near the machine so that it can be seen by all users. By proceeding with installation and operation, you agree that you are fully understand the contents of this manual and take full responsibility for the use of the product.

CONTENTS

WARRANTY	2
SAFETY INSTRUCTION	4
I. PRODUCT FEATURES AND SPECIFICATIONS	6
II. INSTALLATION REQUIREMENT	8
III. INSTALLATION STEPS	10
IV. EXPLODED VIEW	38
V. TEST RUN	43
VI. OPERATION INSTRUCTIONS	44
VII. MAINTENANCE SCHEDULE	45
VIII. TROUBLE SHOOTING	46
IX. CAR LIFT SAFETY TIPS	47
X. LIFT DISPOSAL	47

Explanation of the safety warning symbols used in this manual

 **DANGER** Risk of death or injury.

 **WARNING** Dangerous or unsafe practices that may result in death or injury.

 **CAUTION** Dangerous or unsafe practices that may result in personal injury, product damage or property damage.

ATTENTION Conditions that may result in damage to products or property.

WARRANTY

The warranty period for the steel structure part of new lift machine is 5 years, hydraulic components, bronze bush, slider and plastic parts warranty for 2 years, electrical components and cable warranty for 1 years, rubber pad is consumable without warranty. During the warranty period, the manufacturer will repair or replace the defective parts free of charge and bear the freight cost.

This warranty does not cover damage caused by wearing parts or improper use, damage in transit and damage caused by non-maintenance as required.

This warranty is unique and supersedes what is expressed and implied in all other warranties. The manufacturer shall not be liable for any particular, indirect or accidental damage resulting in breach of or delay in the execution of the warranty. The manufacturer reserves the right to design and improve the product and has no obligation to make notice of the changes in advance.

The product warranty based on the above clause is based on the model number and serial number of the equipment. This information must be provided in conjunction with all warranty information at the time of service and warranty.

SAFETY WARNING LABEL



Fig. 1

SAFETY INSTRUCTION

In order to properly maintain your product and ensure operator safety, it is the responsibility of the product owner to read and follow these instructions!

1. Ensure product installation complies with all applicable local regulations and rules, such as Occupational Safety and Health Administration regulations and electrical codes.
2. Ensure that all operators are properly trained, know how to operate the unit safely, and are properly supervised.
3. Do not operate the product until you are sure all parts are in place and operating correctly.
4. Keep your hands and feet away from the machine. Keep hands and feet away from any moving parts. Keep your feet away from the lift as it descends to avoid pressing on pointed objects.
5. Keep the work area clean. A cluttered workspace can lead to injuries.
6. The machine is only approved for indoor installation and use. Outdoor installation is prohibited.
7. Only trained operators are allowed to handle the lift machine. All untrained persons must stay away from the workplace. Never allow untrained persons to handle or operate the machine.
8. Use the lift properly. Use the lift in the correct way.
9. Warning! Keep no one under the lift when lifting the car.
10. If the vehicle is at risk of falling, keep no one around the lift.
11. Before preparing to approach or service the vehicle, ensure that the safety device is in effect.
12. Dress appropriately when operating machines, and consider wearing non-slip steel-soled shoes for added safety..
13. Beware of electric shock. In order to protect the operator from electric shock, the lift in use must be grounded. Do not connect the green wire to the terminal. This is the ground wire.

14. Danger! The power supply used in this type of lift has high voltage. Please disconnect the power supply before any circuit repair. Unplug in case the power supply is accidentally switched on during maintenance.
15. Warning! There is a risk of explosion. There are parts in the equipment that produce arc light and spark. Do not be exposed to easy gas. This machine should not be placed in the lounge or basement.
16. Maintain with care. Keep the machine clean for better and safer operation. Perform proper lubrication and maintenance procedures according to the manual. Keep handles or buttons clean, dry, and free of oil.
17. Stay alert. Use common sense to observe what you are doing and stay alert.
18. Check for damaged parts. Check for adjustments to moving parts, damage to parts, or anything that may affect their operation. Do not use the machine if the parts are damaged.
19. Do not remove relevant safety parts from the machine. Do not use a lift if it is damaged or missing.
20. Operate the lift only temperature from 41⁰F to 104⁰F (5⁰C to 40⁰C).

 **DANGER** Be very careful when installing, operating, maintaining or repairing this equipment. Failure to comply may result in property damage, product damage, injury or (in very rare cases) death. Ensure that only authorized personnel operate the equipment. All repairs must be carried out by an authorized technician. Do not modify the machine, this voids the warranty and increases the probability of personal injury or property damage.

I. PRODUCT FEATURES AND SPECIFICATIONS

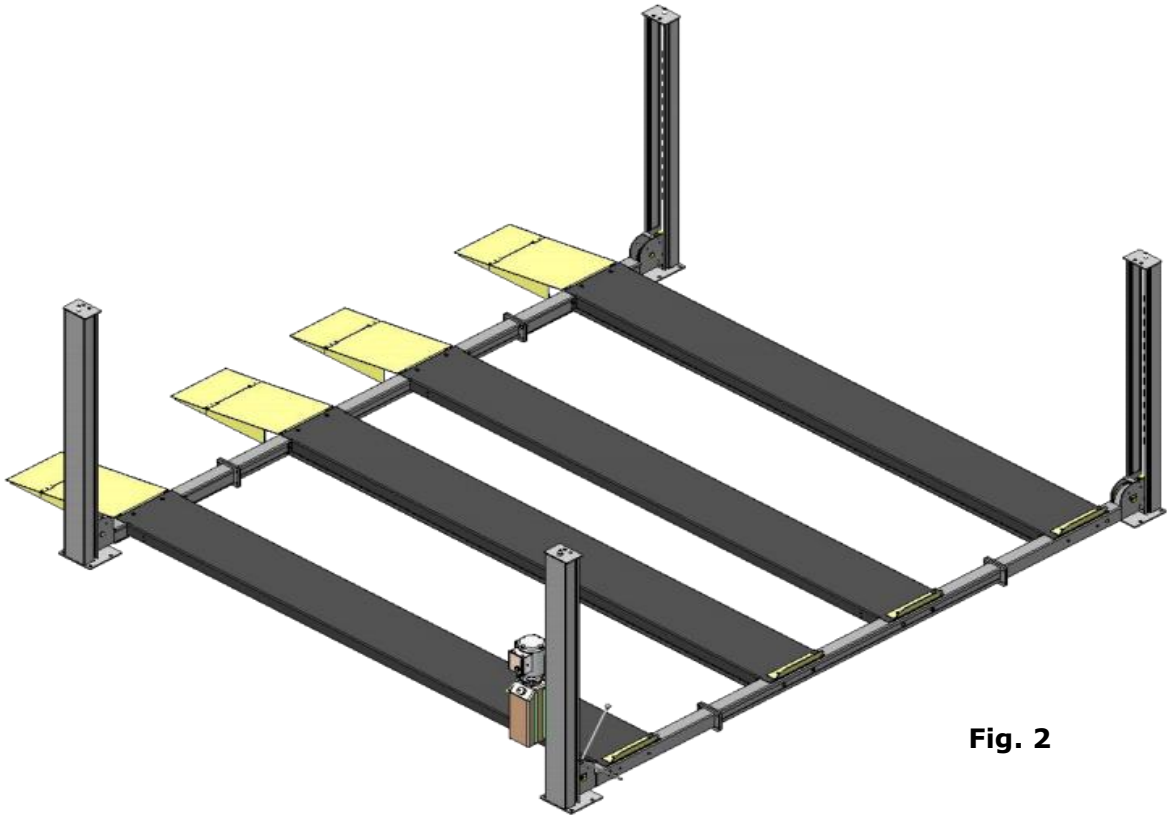

Fig. 2

DOUBLE PARKING FOUR POST LIFT FEATURES

Model 409-DP, 409-DPX

- Cable transmission, driven by single hydraulic cylinder
- Single point manual safety release, more convenient and reliable for decent operation.
- Four mechanical locking devices, include primary mechanical safety lock with secondly cable-brake safety lock , ensure the vehicle safety.
- Double parking design, allows to park 4 vehicles maximum. Max single vehicle weight parked on the platform is 6000lbs (**2800KG**).
- Non-skid diamond platforms and adjustable safety lock ladders.

Dimension

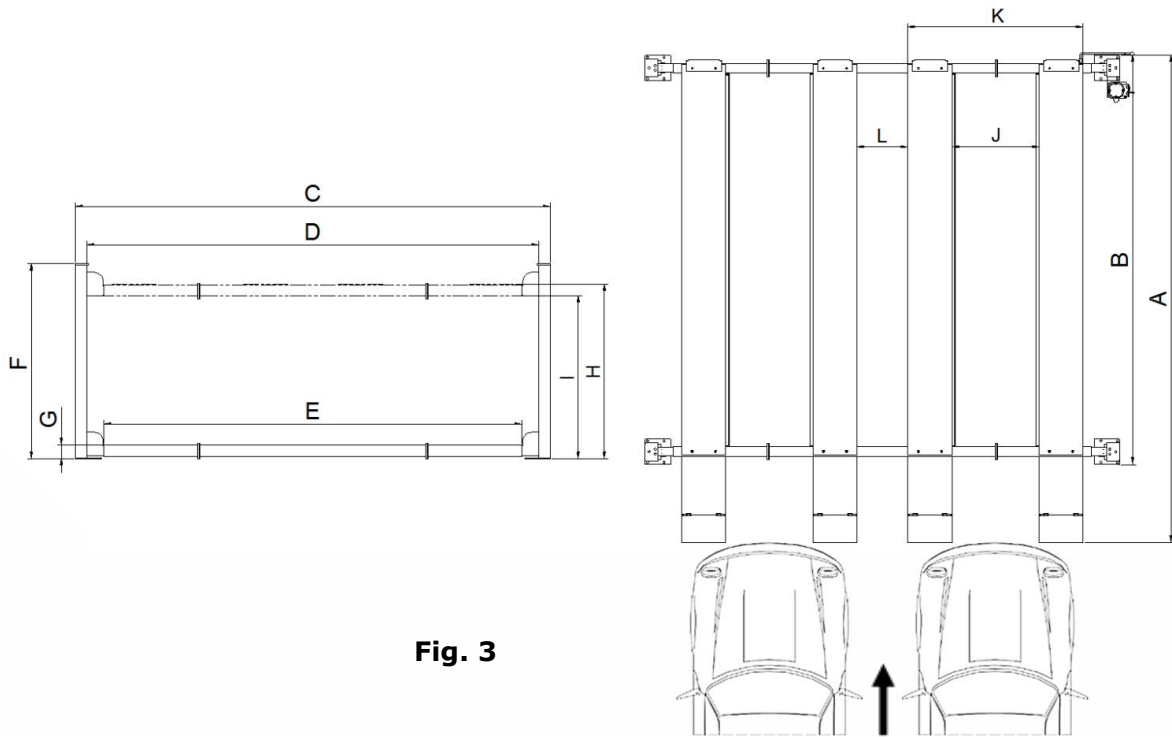

Fig. 3

Car-in Direction

SPECIFICATIONS

Model	Lifting Capacity	Lifting Time	A	B	C	D	E	F	G
			Overall Length (inc. Ramps)	Overall Length (Not Inc. Ramps)	Overall Width	Width Between Columns	Drive Through Width	Overall Height	Minimum Height
409-DP	9,000lbs (4000KG)	47S	207 9/32" (5265mm)	173 13/16" (4415mm)	201 9/16" (5120mm)	192 1/16" (4878mm)	177 23/32" (4514mm)	82 7/8" (2105mm)	6 3/32" (155mm)
409-DPX	9,000lbs (4000KG)	57S	234 27/32" (5965mm)	201 3/8" (5115mm)	201 9/16" (5120mm)	192 1/16" (4878mm)	177 23/32" (4514mm)	96 21/32" (2455mm)	6 3/32" (155mm)

Model	H		I		J	K	L	Motor
	Lifting Height	Max. lock height to top of runway	Max. height underneath runway	Max. lock height underneath runway	Width between runway	Overall width of single parking unit	Width Between two parking units	
409-DP	73 11/16" (1872mm)	70 15/16" (1802mm)	69 3/4" (1772mm)	67" (1702mm)	37" (940mm)	74 13/32" (1890mm)	21 21/32" (550mm)	2.0HP/3.0HP 220V Single Phase
409-DPX	87 11/16" (2227mm)	84 15/16" (2157mm)	83 3/4" (2127mm)	80 31/32" (2057mm)	37" (940mm)	74 13/32" (1890mm)	21 21/32" (550mm)	

⚠ CAUTION When driving the vehicle into the lift, make sure it is positioned in middle of either group of runways. Any hit of the lift could result in damage to either the vehicle or lift.

II. INSTALLATION REQUIREMENT

A.TOOLS REQUIRED

✓Rotary Hammer Drill (Φ19)



✓Carpenter's Chalk



✓Hammer



✓ Screw Sets



✓Level Bar



✓ Tape Measure (7.5m)



✓English Spanner (12")



✓Pliers



✓Wrench set

(10#, 13#, 14#, 15#, 17#, 19#, 24#, 27#, 30#,))



✓ Lock wrench



✓Ratchet Spanner With Socket (28#)



✓ Socket Head Wrench (3#, 5#, 8#)



Fig.84

B. Equipment storage and installation requirements.

- 1 . Store the equipment in a dry, non-moldy, non-flammable environment.
- 2 . The lift is generally approved for indoor installation and use. If need outdoor installation, the optional motor protect cover is required. (Kits No.: 40810)
- 3 . When installing the device, take safety precautions according to the instructions to avoid device damage.
- 4 . During installation, all parts should be fastened to ensure the stability and smooth operation of the machine.
- 5 . After installation, the whole machine should be checked to make sure that every component is working properly.

C. The equipment should be unload and transfer by forklift.



Fig.5

D. SPECIFICATIONS OF CONCRETE (See Fig. 7)

Specifications of concrete must be adhered to the specification as following. Failure to do so may result in lift and/or vehicle falling.

1. Concrete must be thickness 4" minimum and without reinforcing steel bars, and must be totally dry before lift installation.
2. Concrete must be in good condition and must be of test strength 3000psi (210kg/cm²) minimum. Solidify at least 15 days.
3. The installation ground must be smooth and level without cracks.

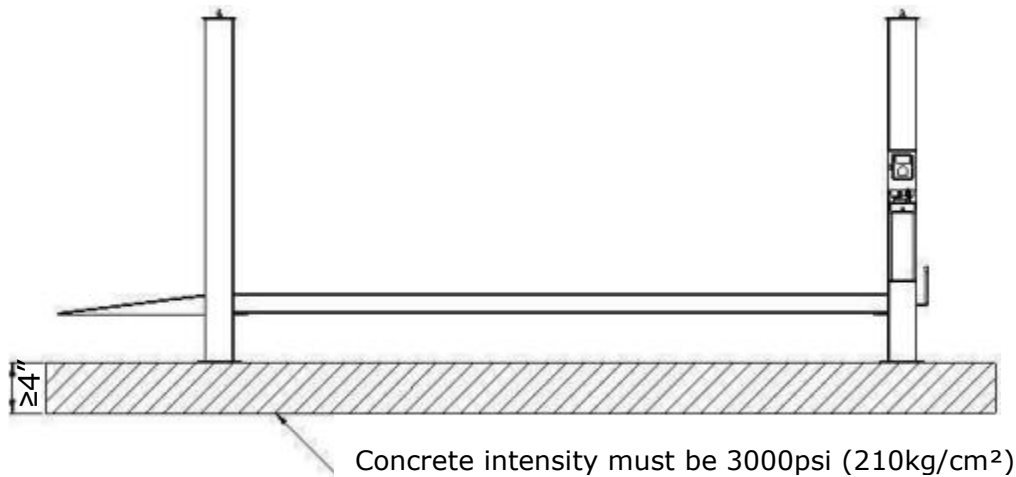

Fig. 6

E. POWER SUPPLY

1. You are required to engage a licensed and qualified electrician for the installation process.
2. The power supply must be 220VAC single phase, with a cord larger than 3.3mm² (12AWG), and must be properly grounded.

⚠ DANGER All electrical wiring must be performed by a licensed and certified electrician. Attempting to connect the circuit without proper certification may result in damage to the lift or electrocution, resulting in serious injury or death.

III. INSTALLATION STEPS

A. Location of installation

1. Installation space: Ensure there is enough space for the lift. Accurately measure the front, back, side and top mounting dimensions and refer to the below figure data (**See Fig. 7**).
2. Overhead obstacle: Check for overhead obstacles, such as building supports, heaters, lights, wires, and low ceilings, etc..

3. Installation: The lift is only approved for indoor installation and use. If need outdoor installation, the optional motor protect cover is required. (Kits No.: 40810)
4. Floor: Install lift only on flat concrete floor. Do not install on asphalt or any other surface. The surface must be flat. Do not install if the surface slope exceeds 3°.

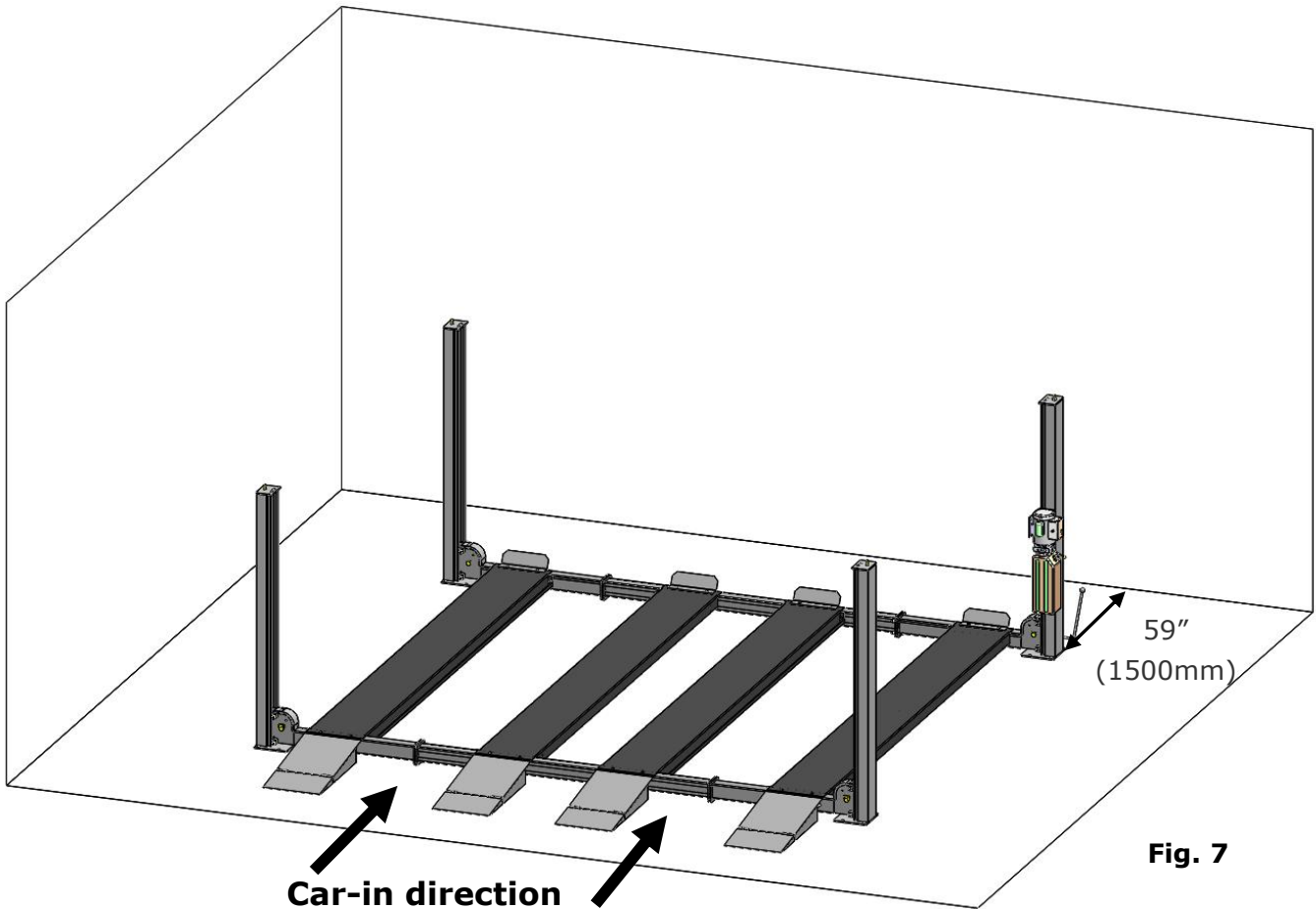

Fig. 7

Lift installation and concrete construction must comply with the latest version of the National standard "Automotive Lifts - Safety Requirements for Construction, Testing and Verification". Uniform building codes of other agencies or International Building Codes (IBC) for any special regional structures must meet seismic standards.

B. Check the parts before assembly. Make sure all parts of the lift are complete.

1. Packaged lift and hydraulic power unit(See Fig. 8).



Fig. 8

2. Move the lift aside with a fork lift or hoist, unpack the lift, tear off the shipment parts list and check the components in the package according to the list. (See Fig. 9)

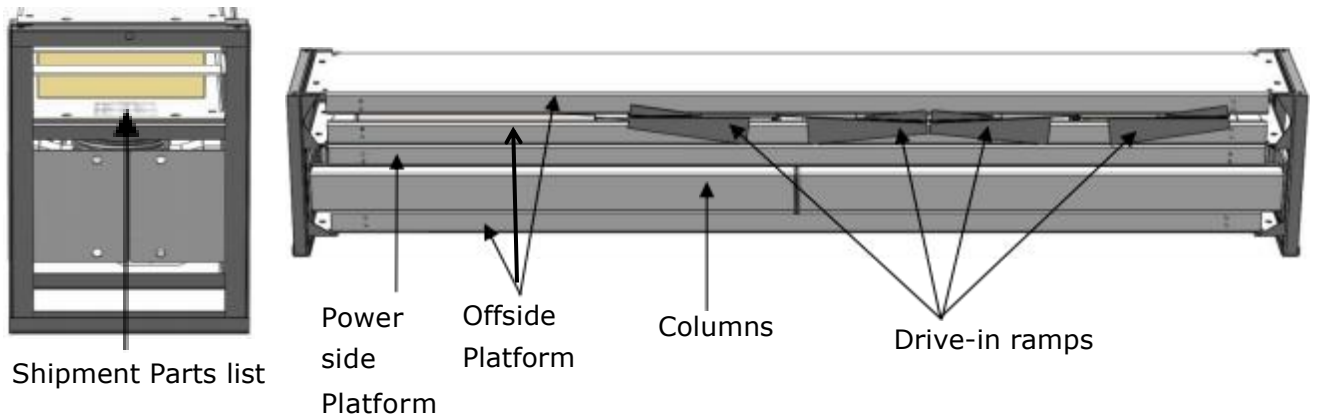

Fig. 9

3. Loosen the bolts of the upper package, then take out the offside platform on the top. (See Fig. 10)

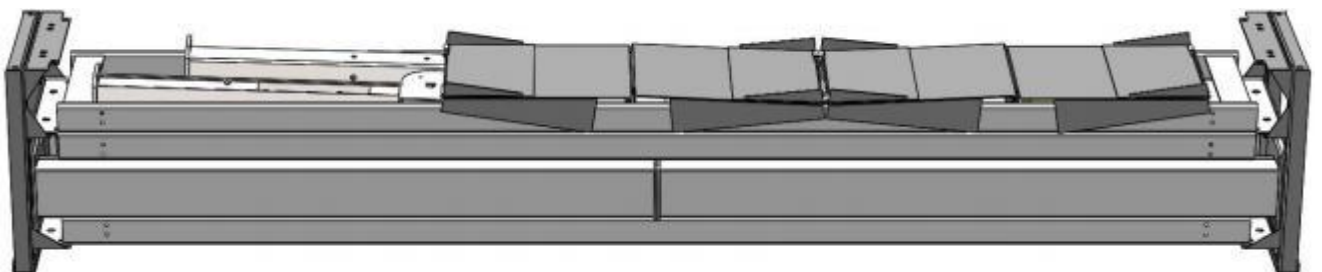

Fig. 10

4. Take out the parts in the offside platform, loosen the bolts of the middle package, take out the offside platform/power side platform of the middle package. **(See Fig. 11)**

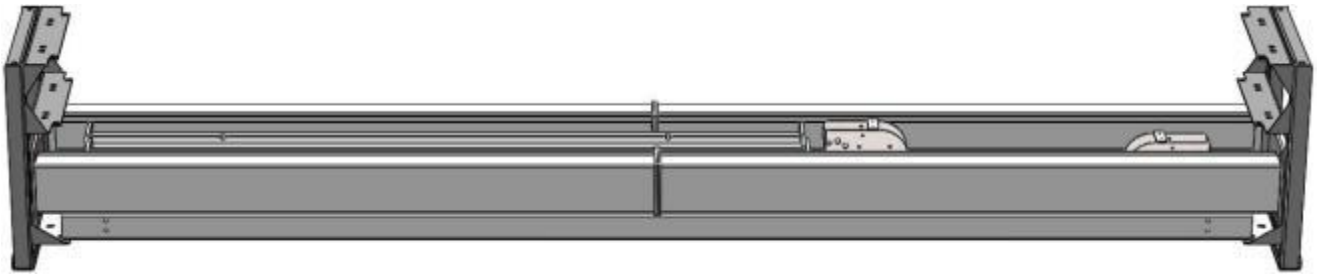

Fig. 11

5. Take out the parts in the offside platform, take offer the package rack.
6. Move aside the parts and check the parts according to the shipment parts lift. **(See 12)**

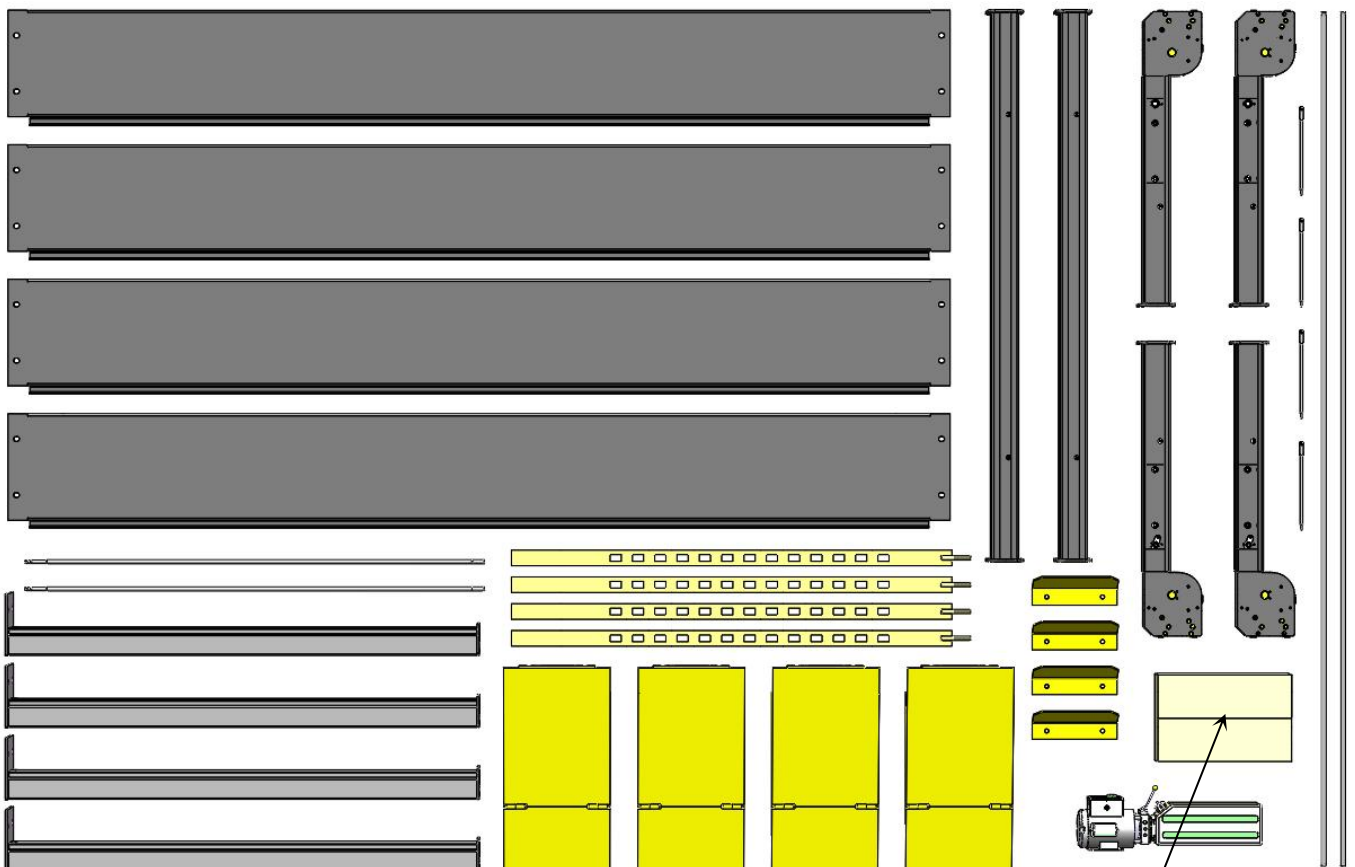

Fig. 12

73/

C. Use a carpenter's chalk line to establish installation layout as per Fig.15. Place the columns at the right position.

Note: Reserve space front and behind the installation site.

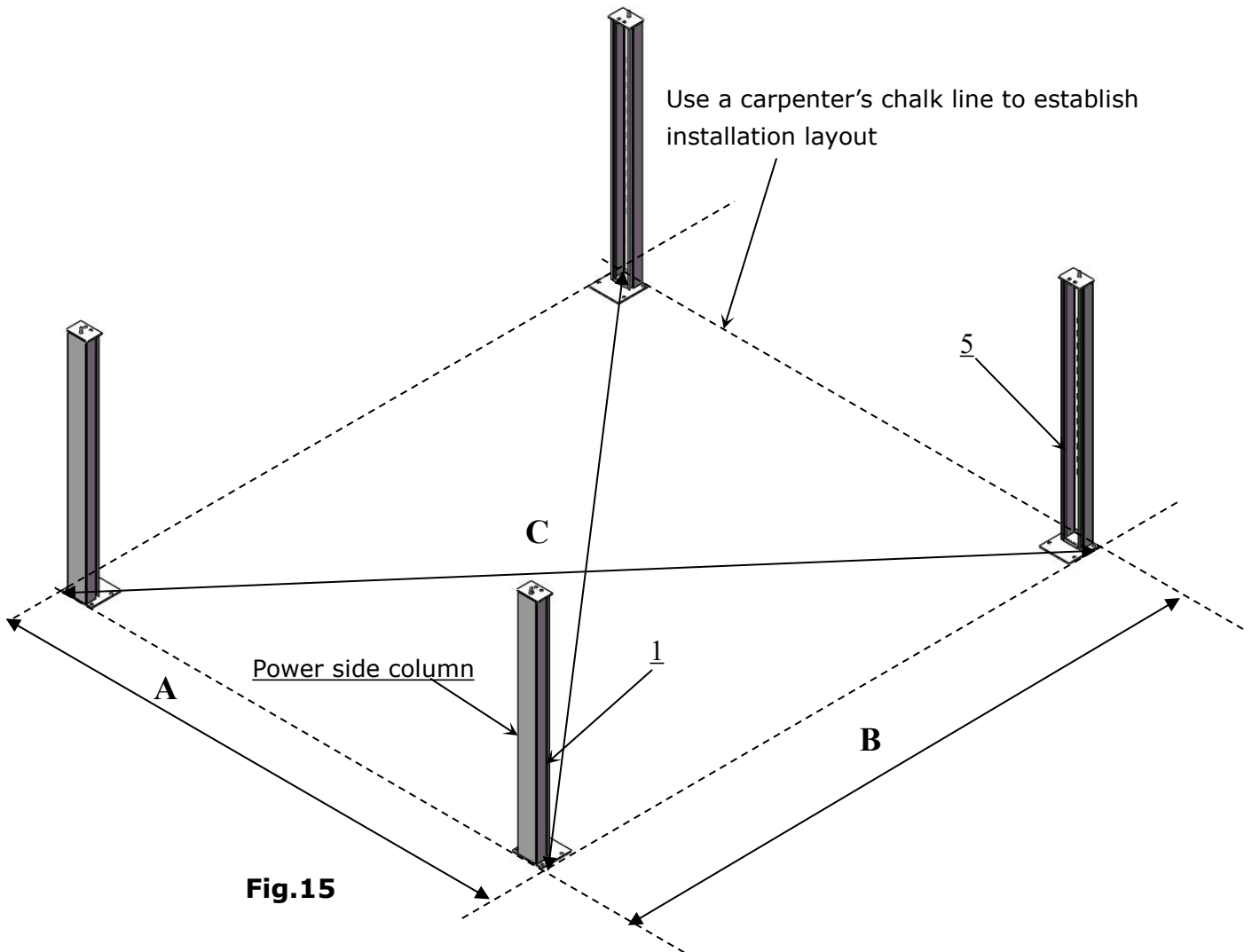
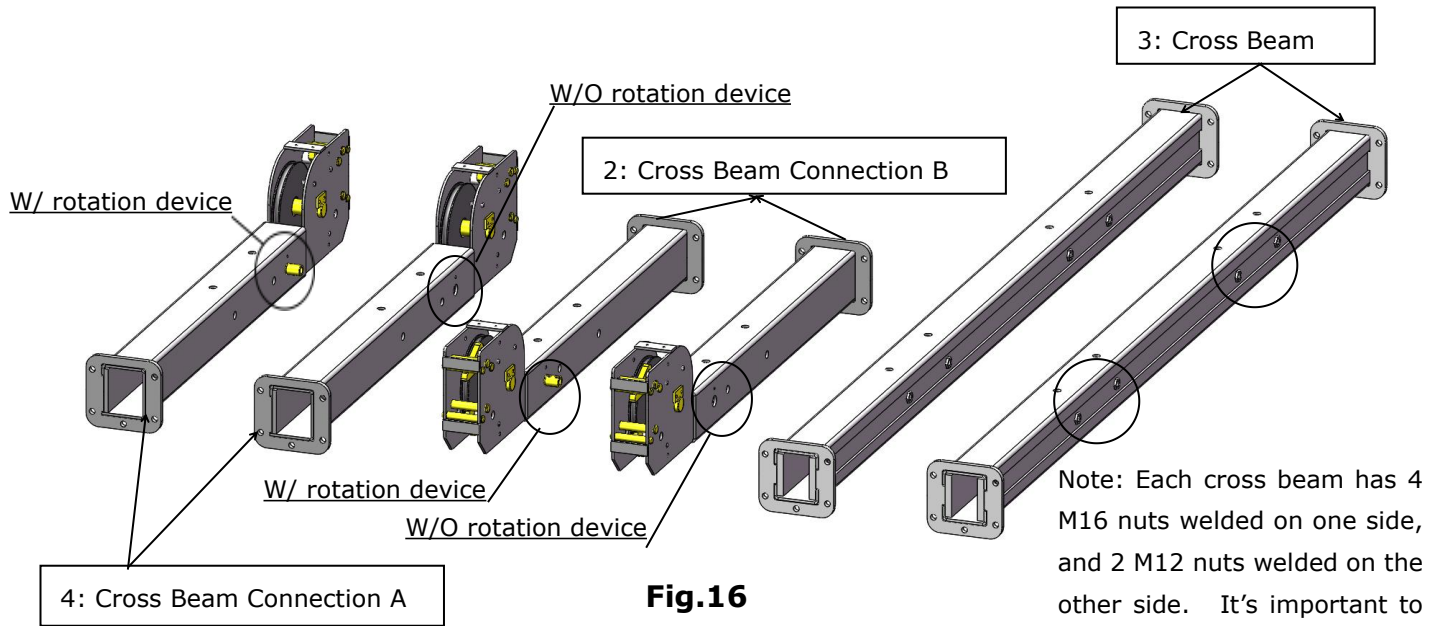

Fig.15

MODEL	A	B	C
409-DP	4415mm (173 13/ 16")	5120mm (201 9/ 16")	6761mm (266 3/ 16")
409-DPX	5115mm (201 3/8")	5120mm (201 9/ 16")	7237mm (284 29/32")

D. Install cross beam assy.

1. Prepare the assembly parts shown as below, see fig 16



2. Install cross beam assy. See fig 17.

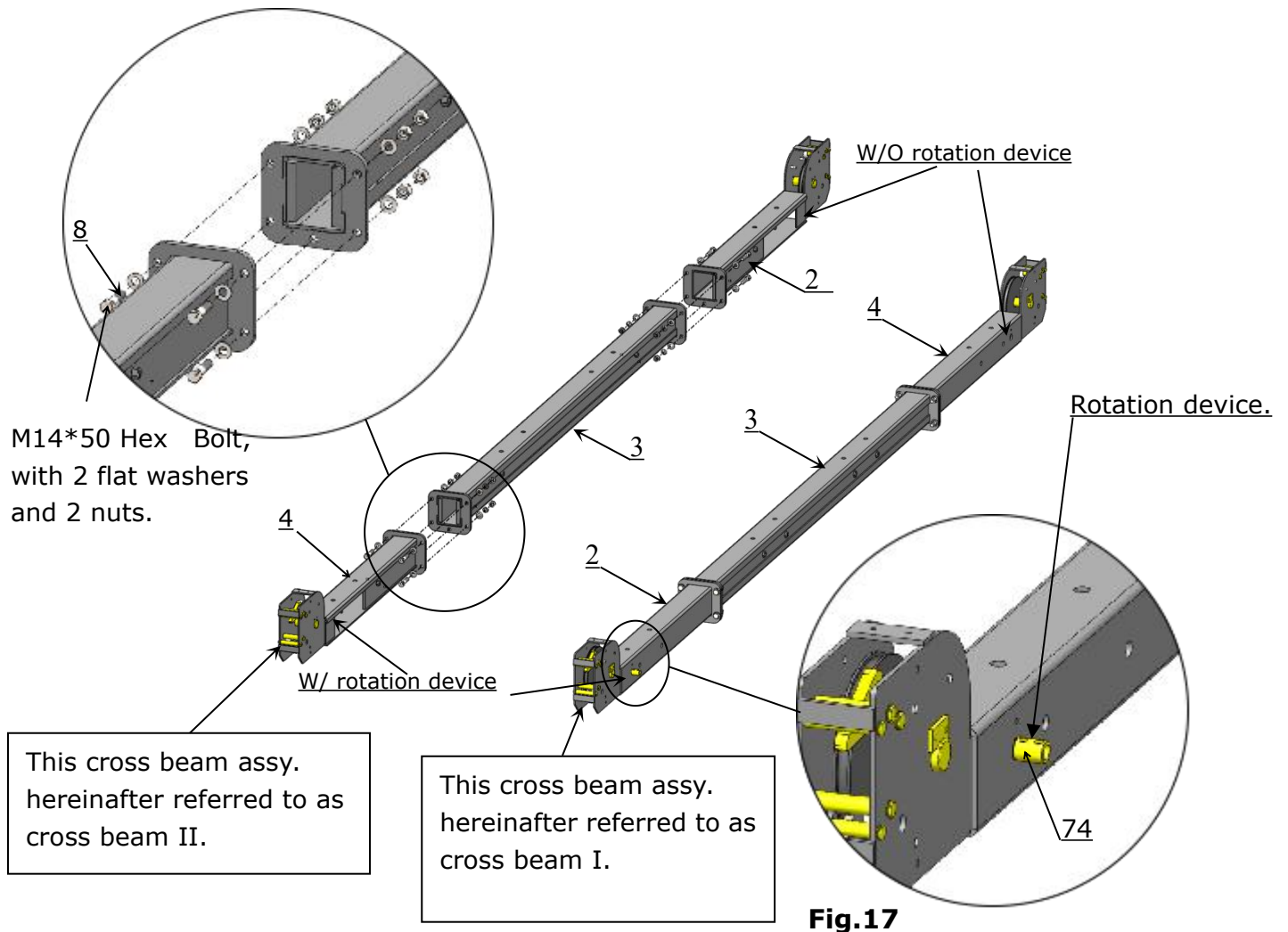

Enlarged view after installation.

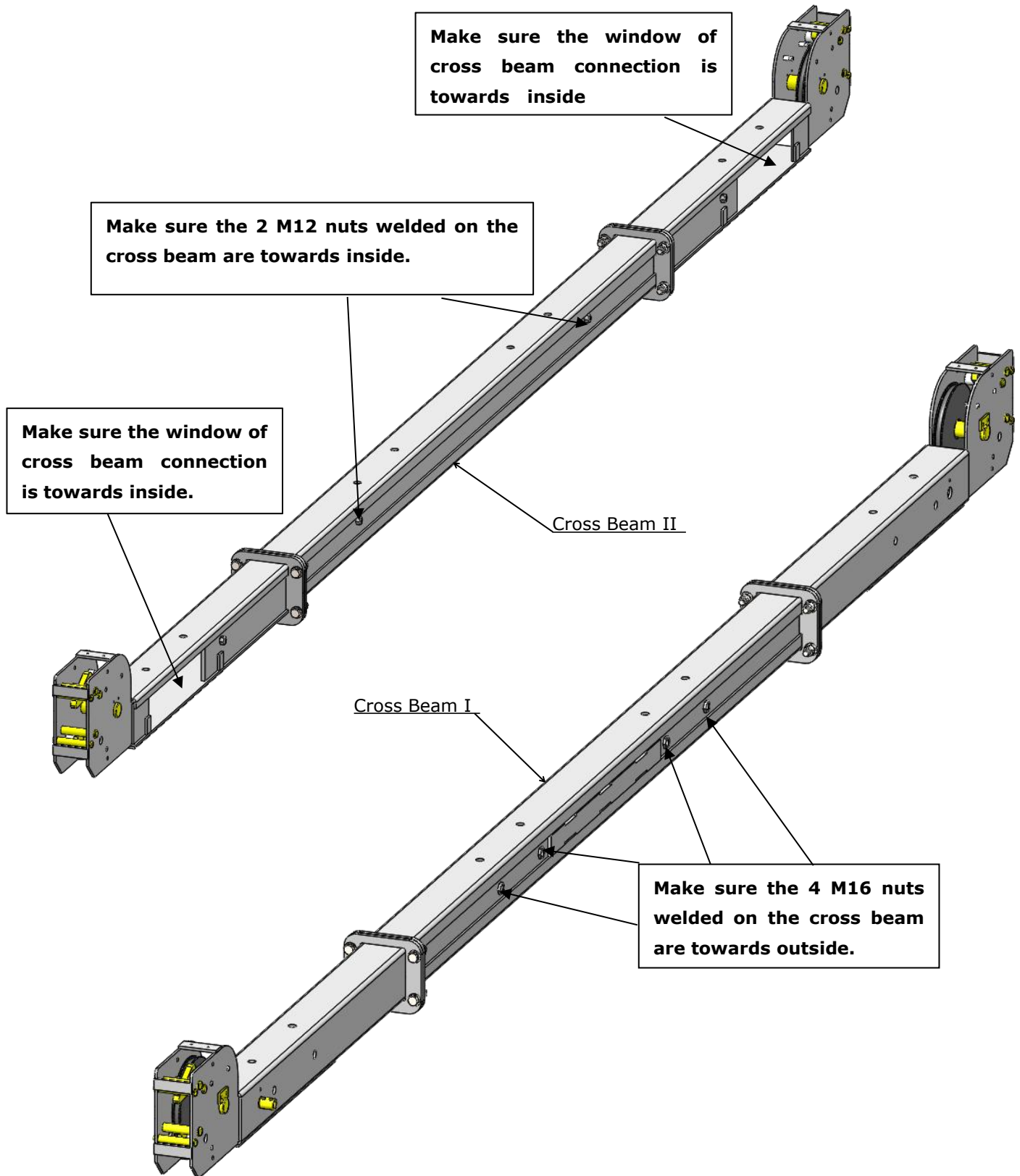

Fig.18

E. Assemble safety device coupling bar assembly, and bolted with cross beam assembly .

1. One safety device coupling bar assembly include one unit coupling bar, two units connecting bar, all parts see fig 19.

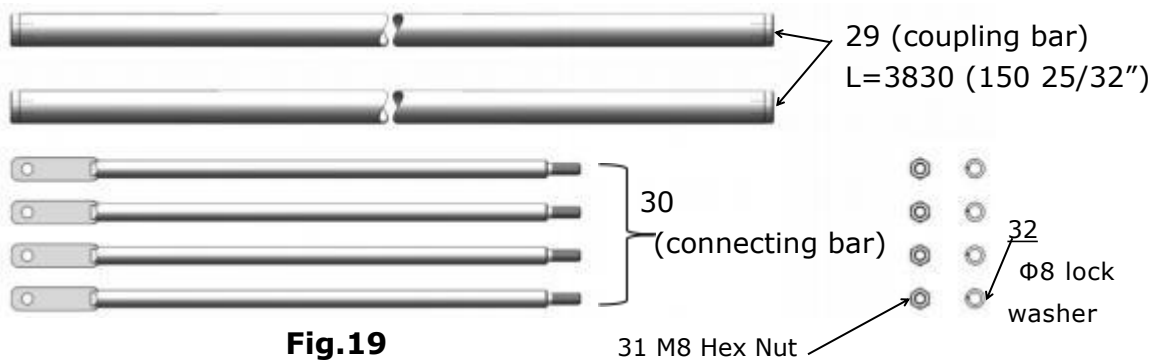

Fig.19

2. Assembly of coupling bar assembly. See fig 20

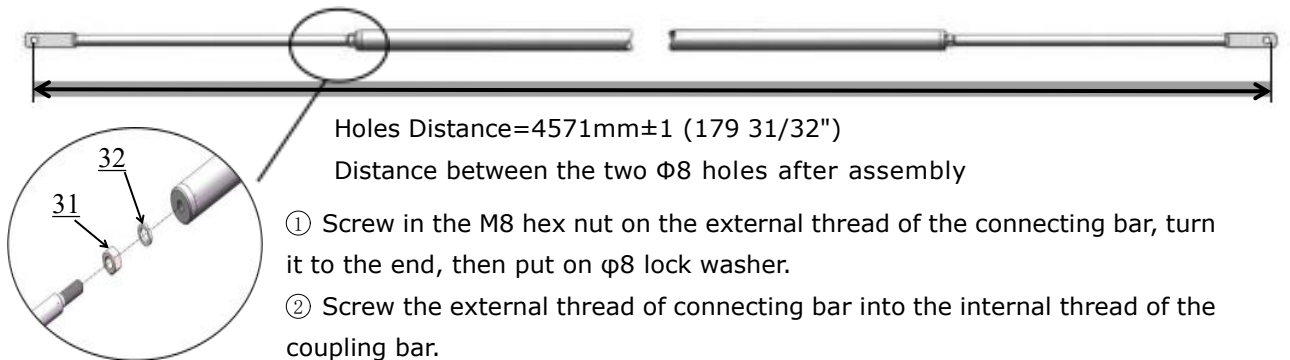

Fig.20

- ① Screw in the M8 hex nut on the external thread of the connecting bar, turn it to the end, then put on $\phi 8$ lock washer.
- ② Screw the external thread of connecting bar into the internal thread of the coupling bar.
- ③ Adjust the $\phi 8$ holes of the connecting bar at both ends to the correct distance, then tighten with two M8 nuts.

Note: the $\Phi 8$ holes of the connecting bar at both ends should be parallel to each other after installation.

3. Bolt safety device coupling bar assembly with the cross beam assembly. Make sure the safety device works well. See fig 21.

Pass the safety device coupling bar assy into the cross beam assy from the side

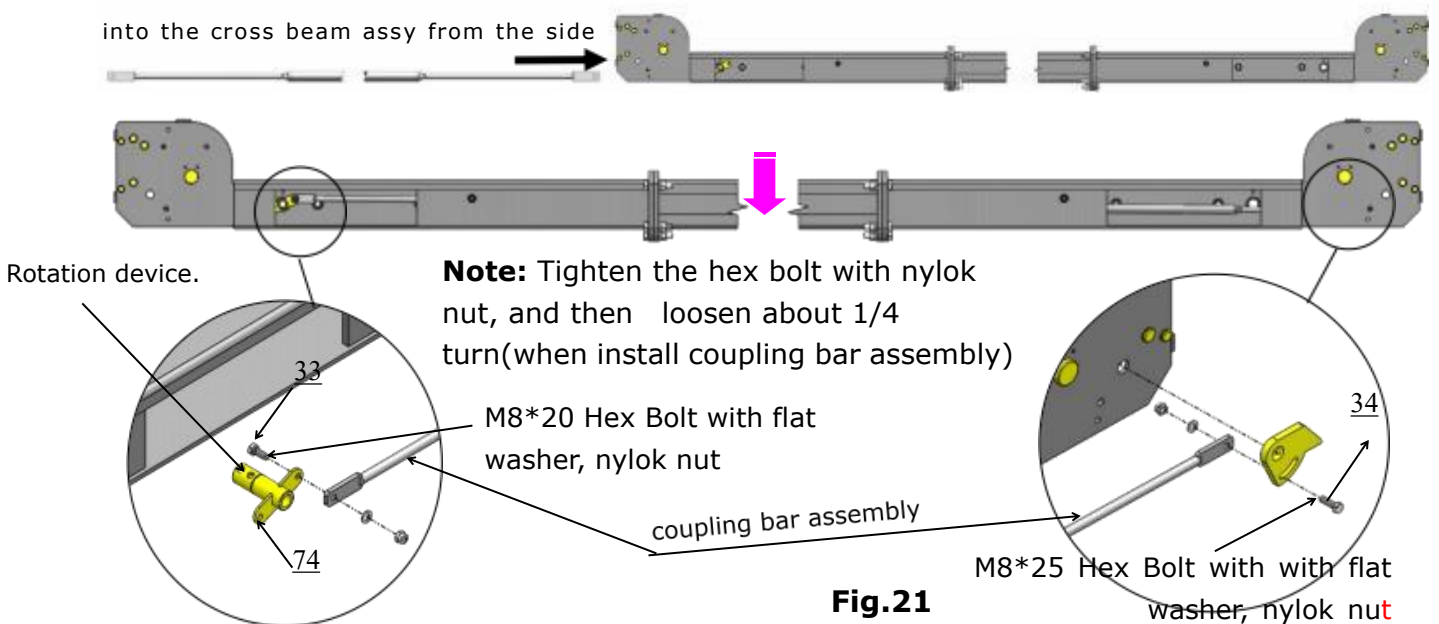

Fig.21

F. Install cross beam assy. to columns

Noted: The windows of cross beam assy. should be towards inside, and the rotation devices should be at the same side of power side column. See Fig.22

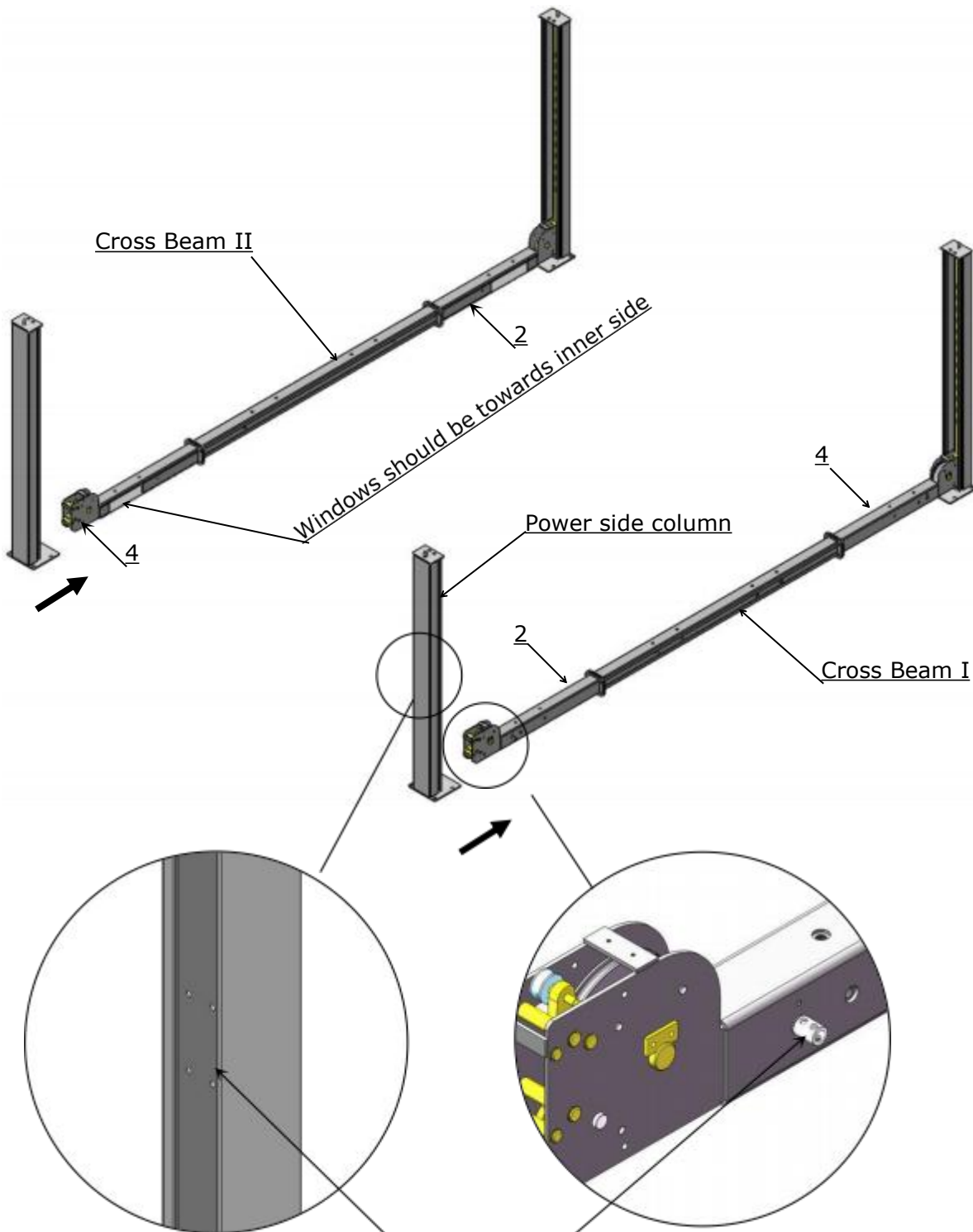

Fig.22

The column with 4- Φ 10 holes is power side, and rotation device must be towards outside.

G. Install the Safety Ladders.

1. Remove one nut from the safety ladders, and adjust the other nut to the proper position that all nuts of 4 safety ladders at the same position. Then install the safety ladders. **(See Fig. 23).**

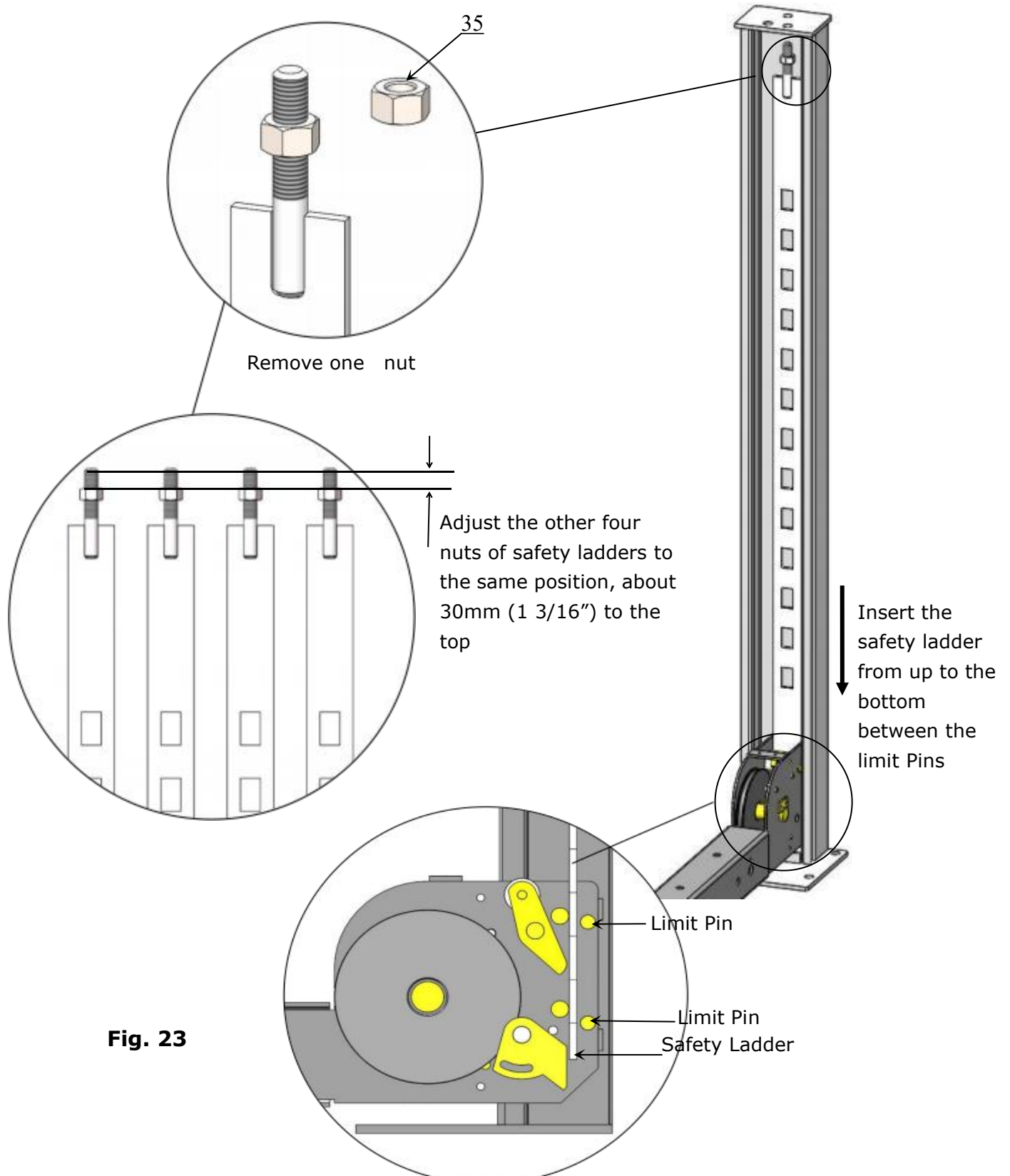
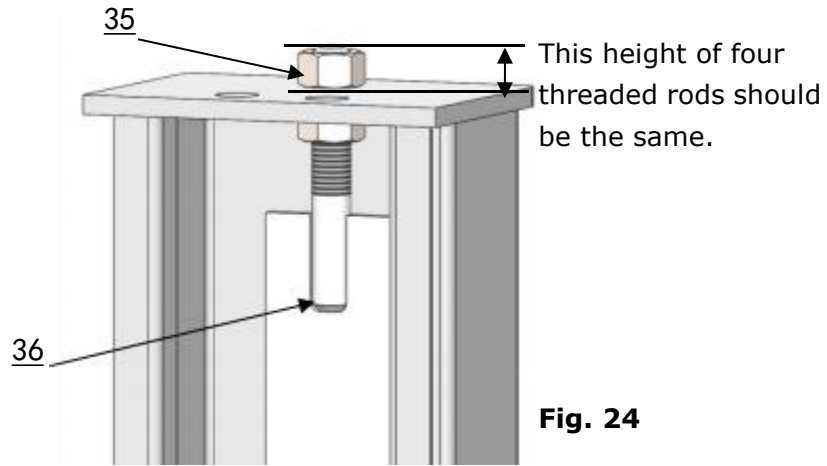

Fig. 23

Make sure the safety ladder is inserted between the limit pins.

2. Install Safety Ladders (See Fig. 24).



Pass the safety ladder through the hole of the top plate, then tighten the two nuts.

H. Put the cross beams to the same height and lock at the safety ladder (See Fig. 25).

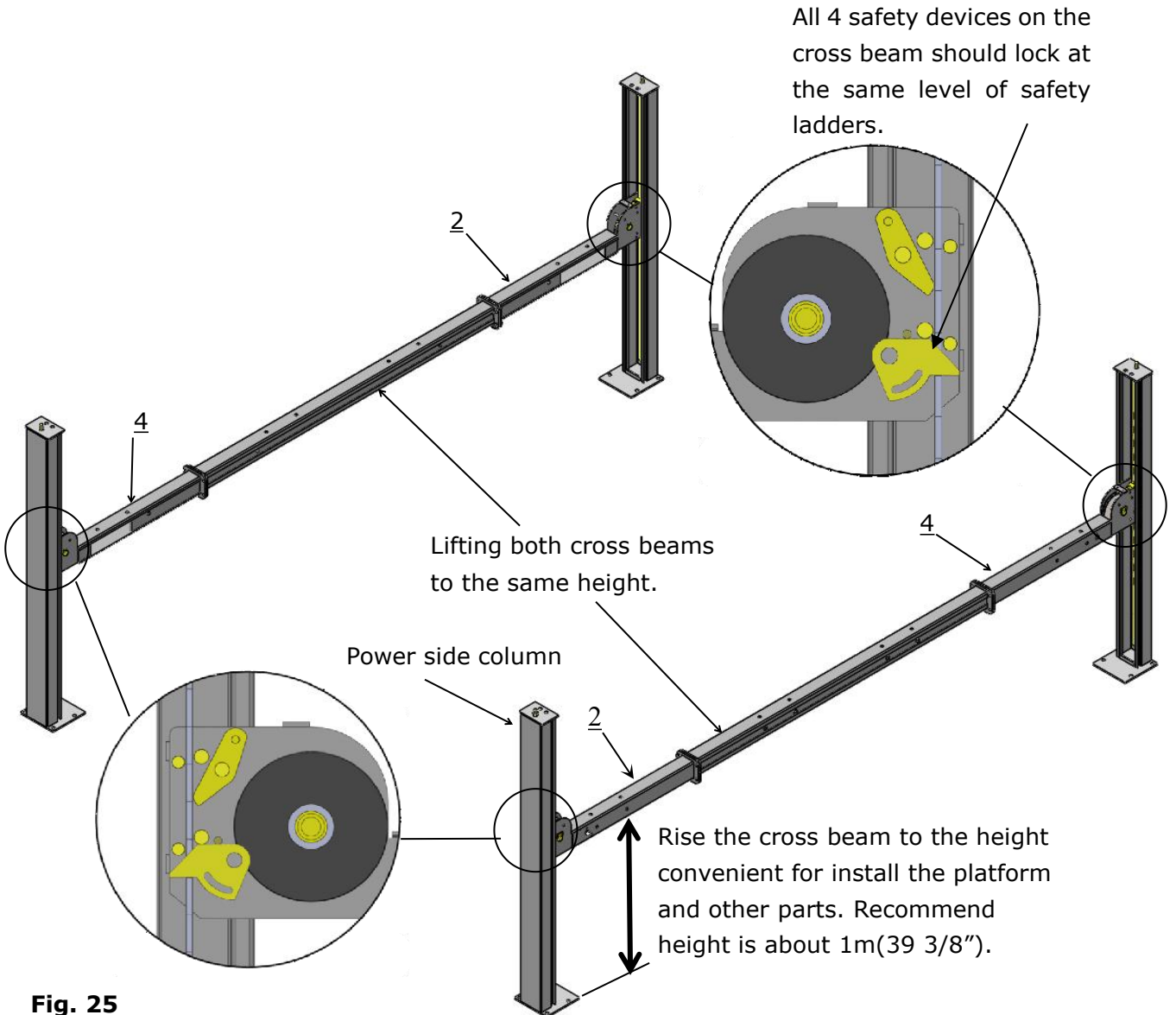

I. Install power-side platform.

1. Install the power side platform on the cross beams by a fork lift or manual, offset the cross beams to outside a little until the pulleys of both platforms enter into the cross beams opening (**See Fig.26**). Aligning holes on the power side platform and cross beam, then screw up the bolts.

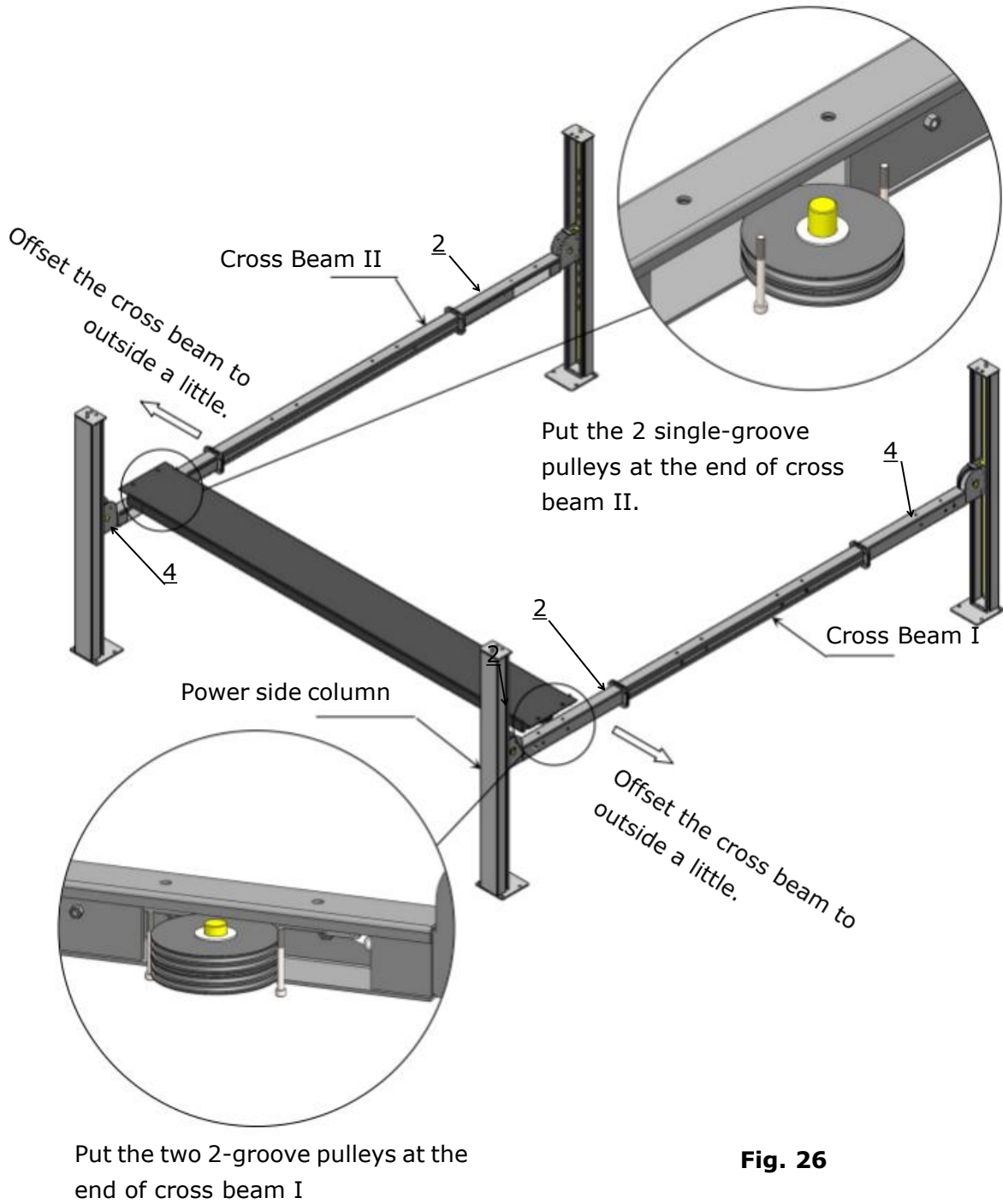

Fig. 26

2. Install connecting bolts of power side platform and cross beam.

Use the connecting bolts to connect the cross beam and platform, no need to tighten at this step.

Note: Tire stop is installed at the front direction, the bolts for it are longer than for the rear side, please pay attention to it. **(See Fig.27)**

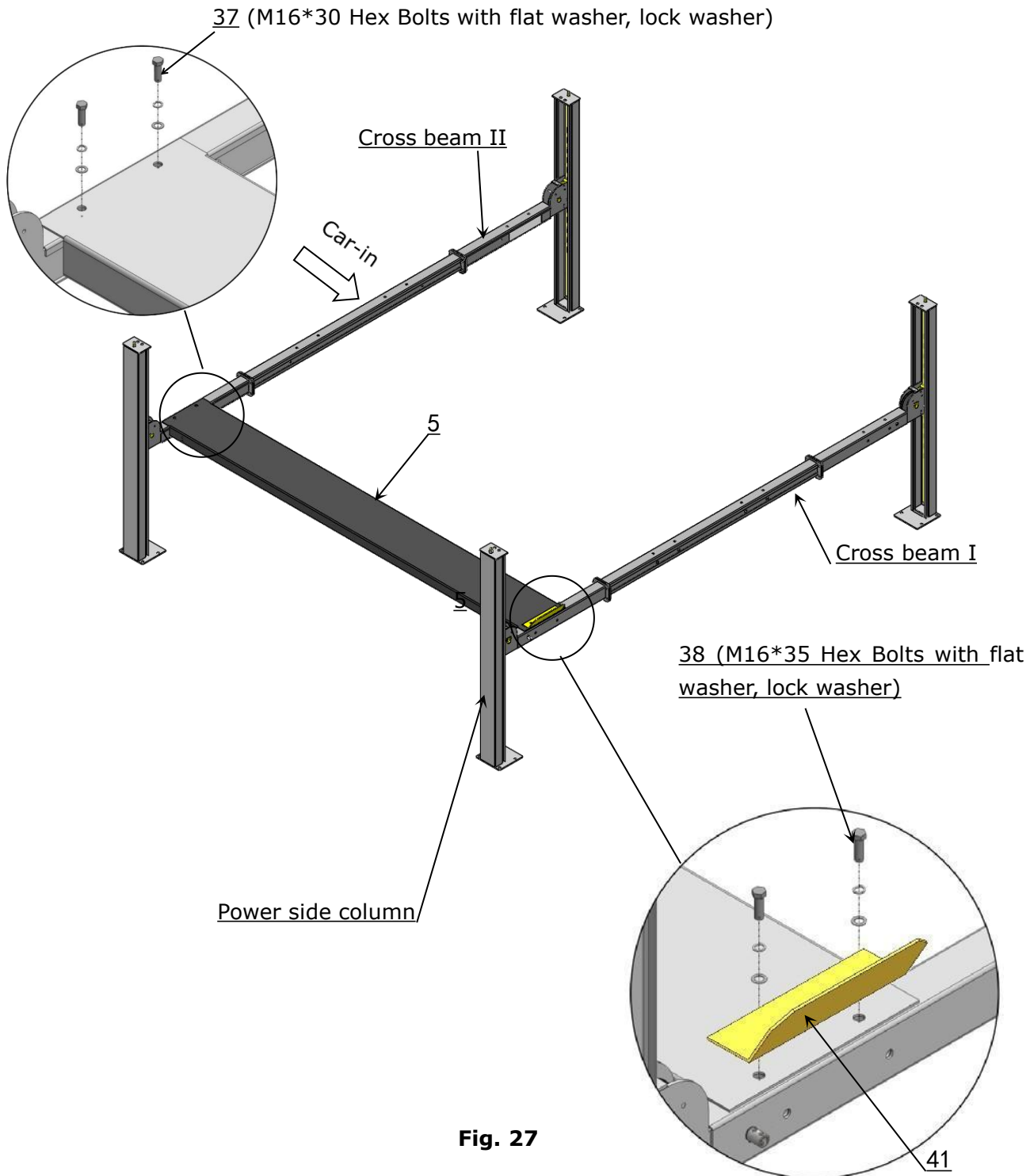
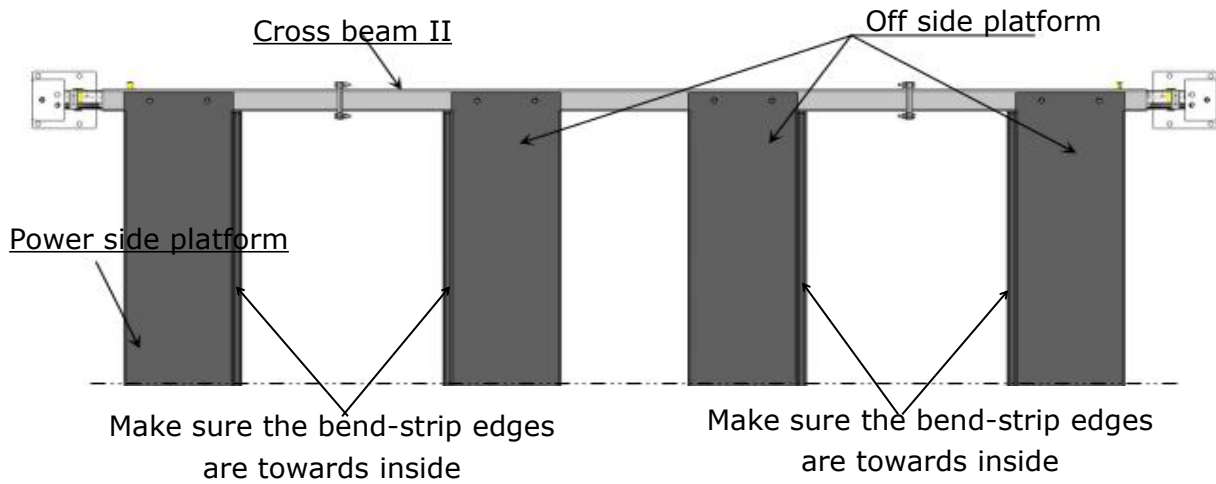

Fig. 27

J. Install off side platform

1. Place the off side platform onto the cross beam. Note: Pay attention to the bend-strip edge of the platform, must be placed same as fig 28.



Pay attention to the difference of bend-strip edges of two models.

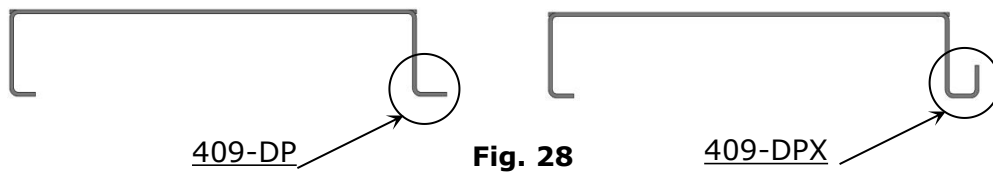

Fig. 28

2. Install platform connecting bolts, follow the same steps as power side platform. See fig 29.

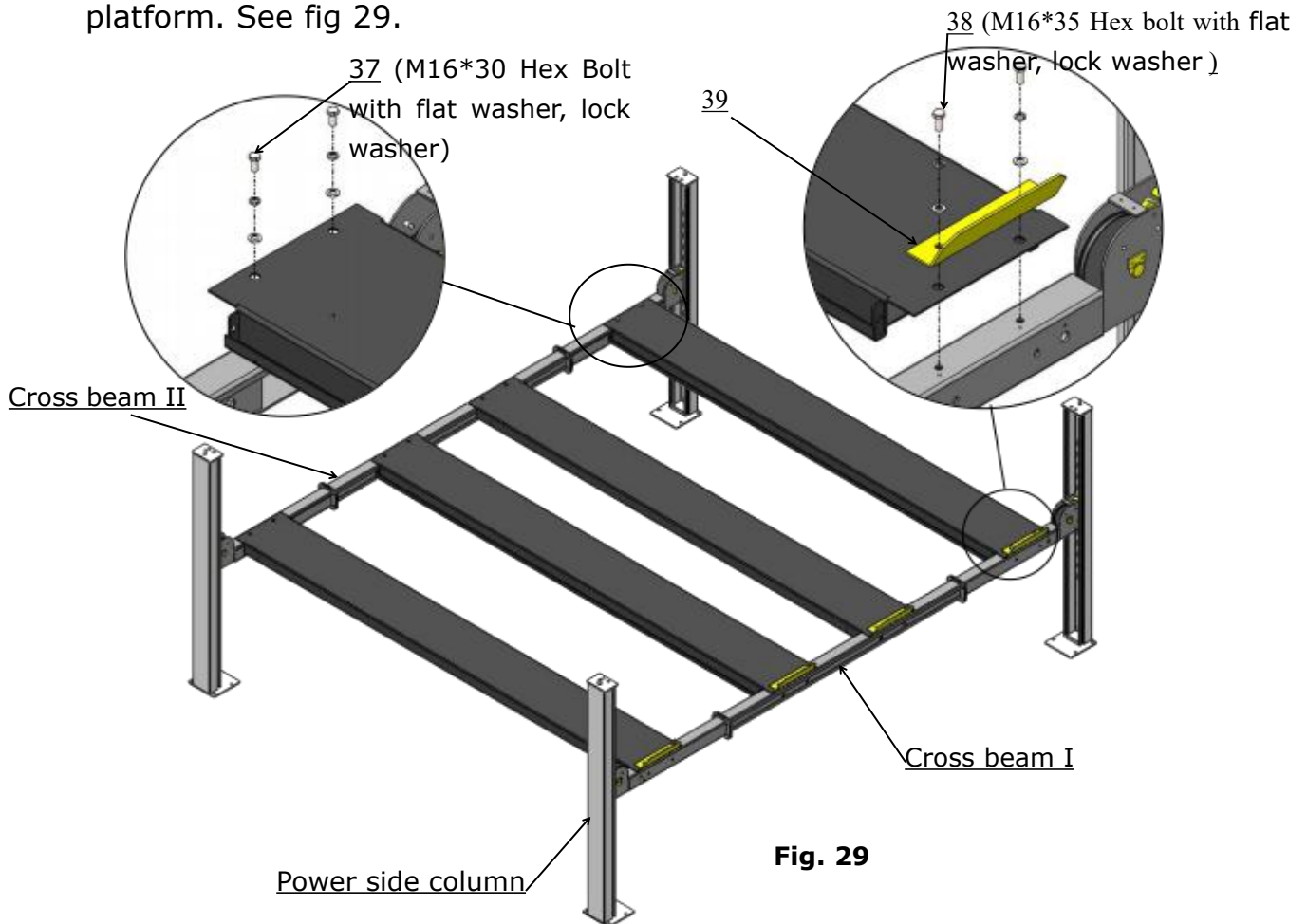

Fig. 29

3. Install platform side connecting bolts and cross beam slide blocks. Finally, tighten all the connecting bolts of platform.

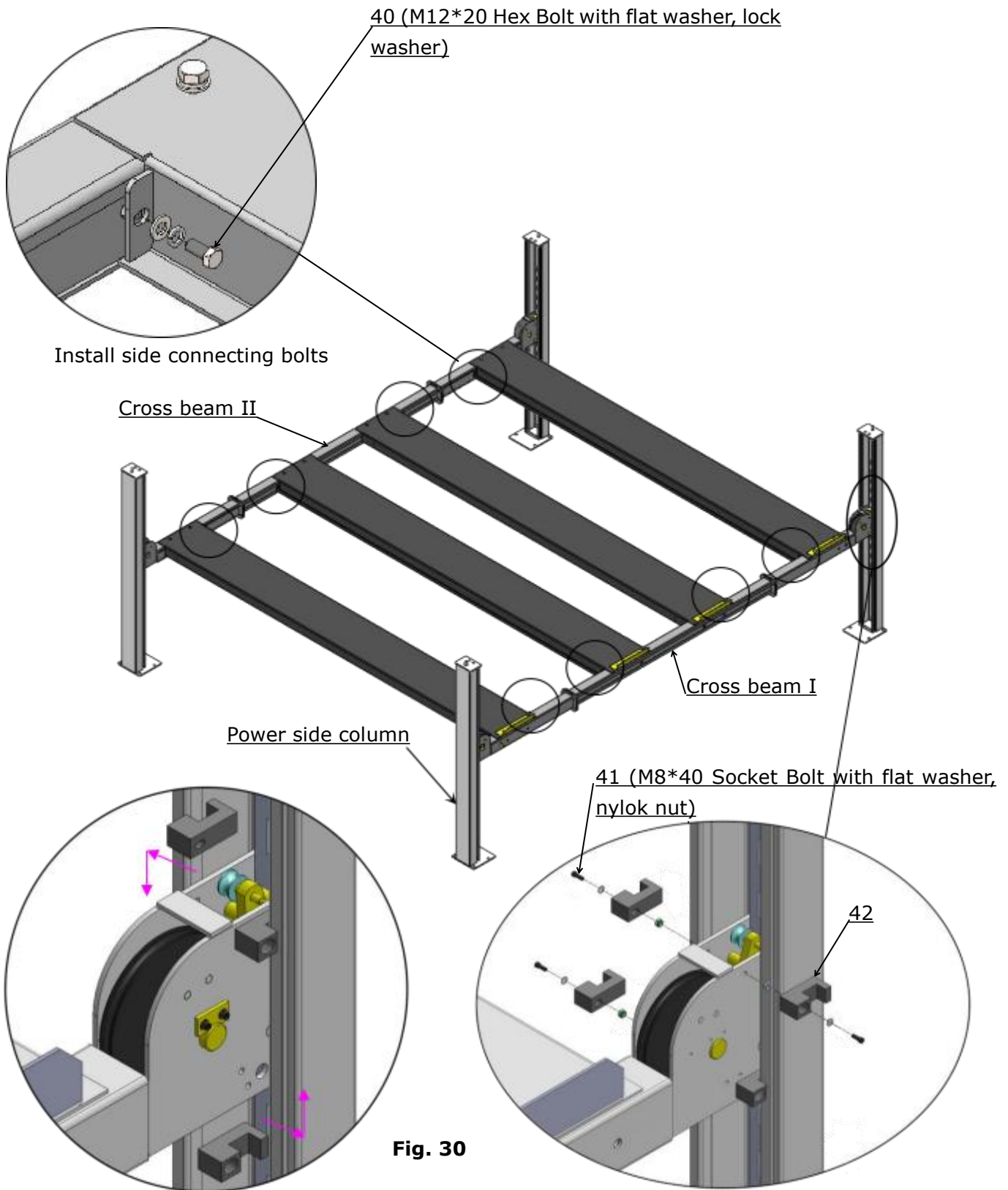
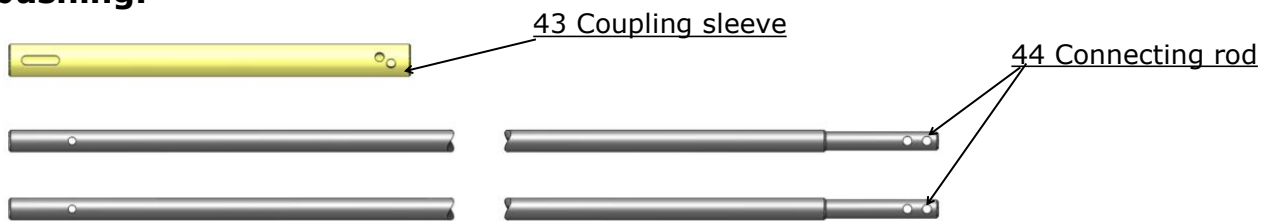

Fig. 30

Pass the slide block along the bend edges of column to the gap between column and cross beam. Align to the mounting holes of cross beam and bolt with cross beam.

Note: DO NOT completely tighten the socket bolt with self locking nut when install the limit slide blocks. Loosen 1/4 turn after tightening.

K. Install safety device connecting rod, Release handle and articulate bushing.



1. Install safety device connecting rod and Release handle, see fig 31

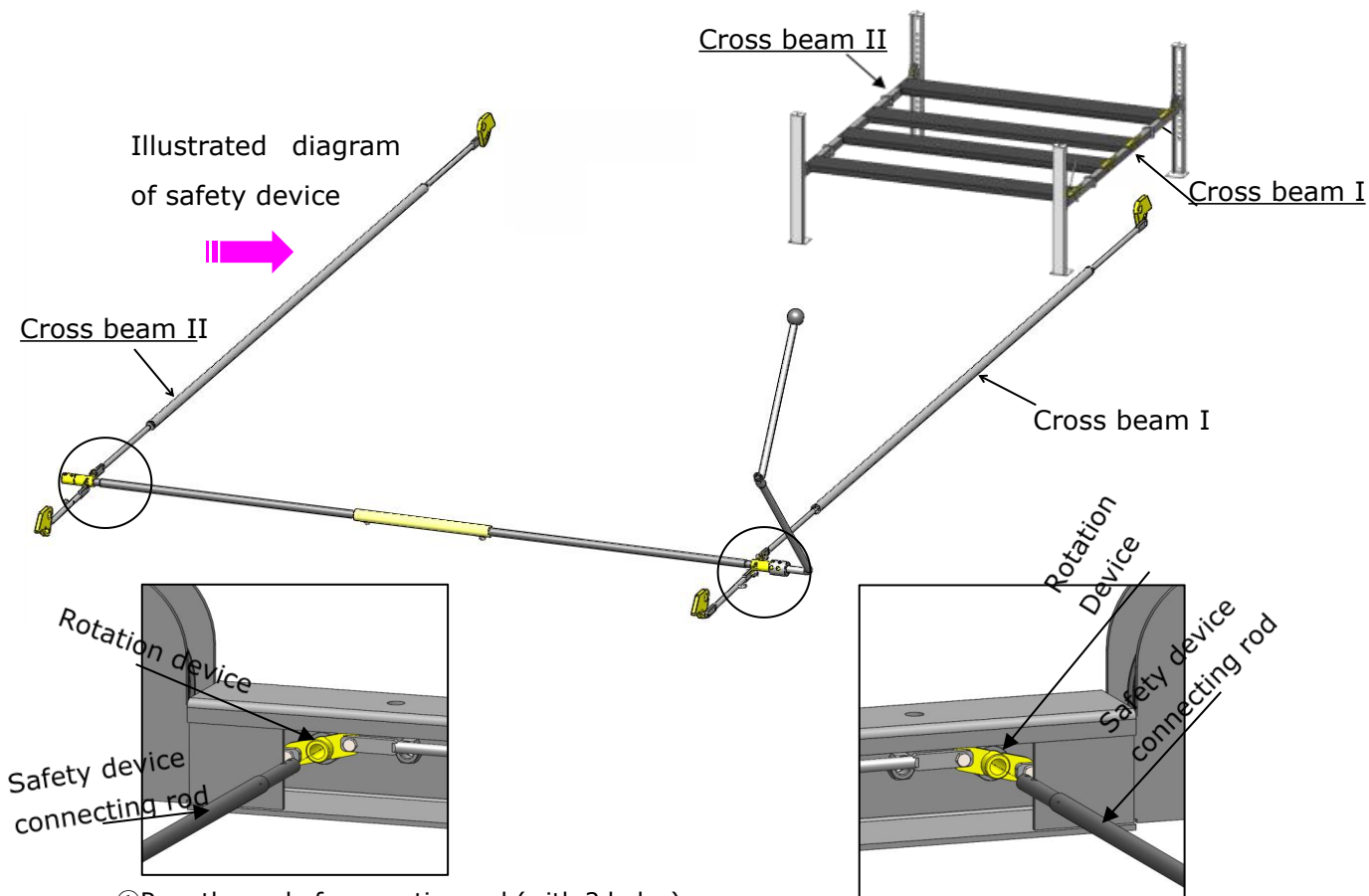

① Pass the end of connecting rod (with 2 holes) through the rotation device of inner side of cross beam II

③ Following the same step to install another rod to cross beam I

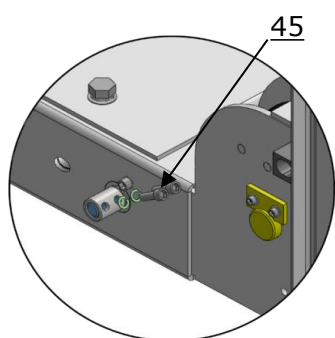

② Align the mounting hole on the outside of cross beam II, tighten with M8*35 socket bolt with lock washer.

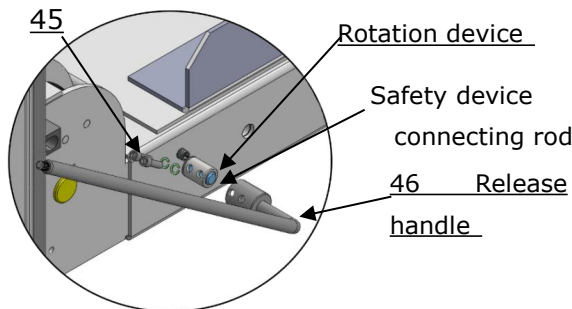

④ Install Release handle on the cross beam I, align the mounting hole, tighten with M8*35 socket bolt with lock washer.

Fig. 31

⑤ Install extended release handle and pull rope.

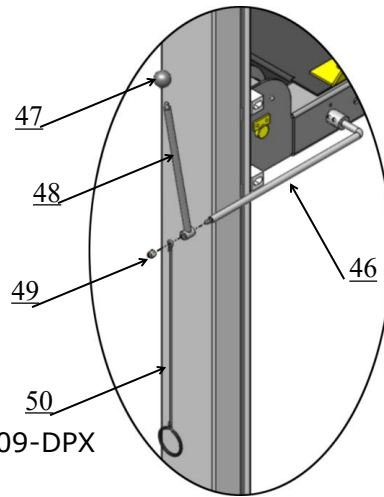

Pull rope only available for 409-DPX

2. Install coupling sleeve

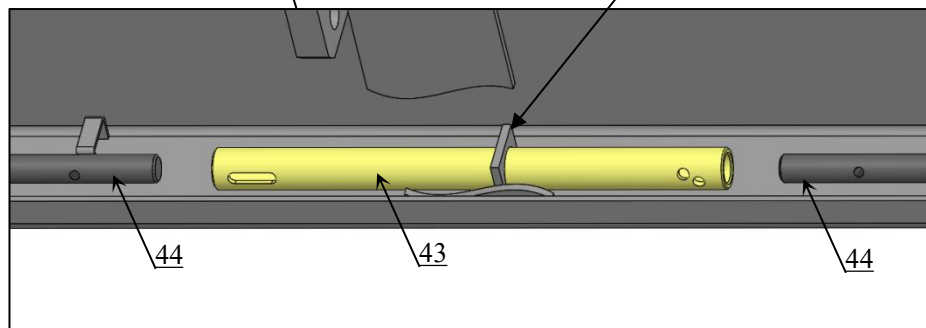
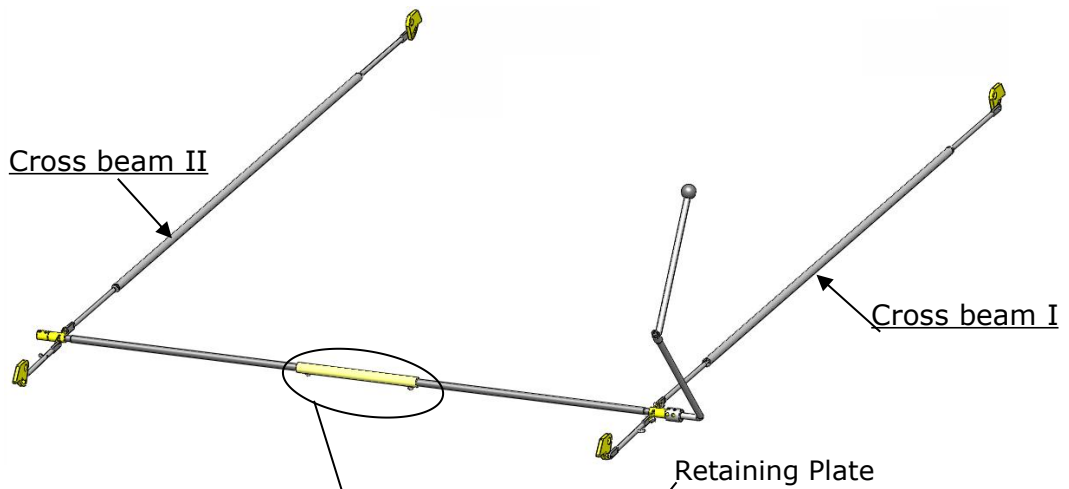

① Pass the coupling sleeve through retaining plate, then put the safety device connecting bar (threaded side) into it.

View from the bottom

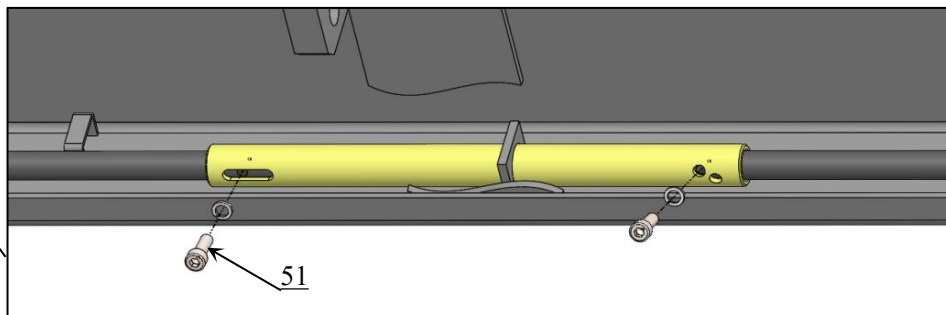

Fig. 32

② Align the holes that connecting the connecting bar and coupling sleeve as show above, tighten with M28*25 socket bolt with lock washer.

L. Installation of cables

1. Pass the cables from platform to the columns according to the number of the cables
(See Fig.33).

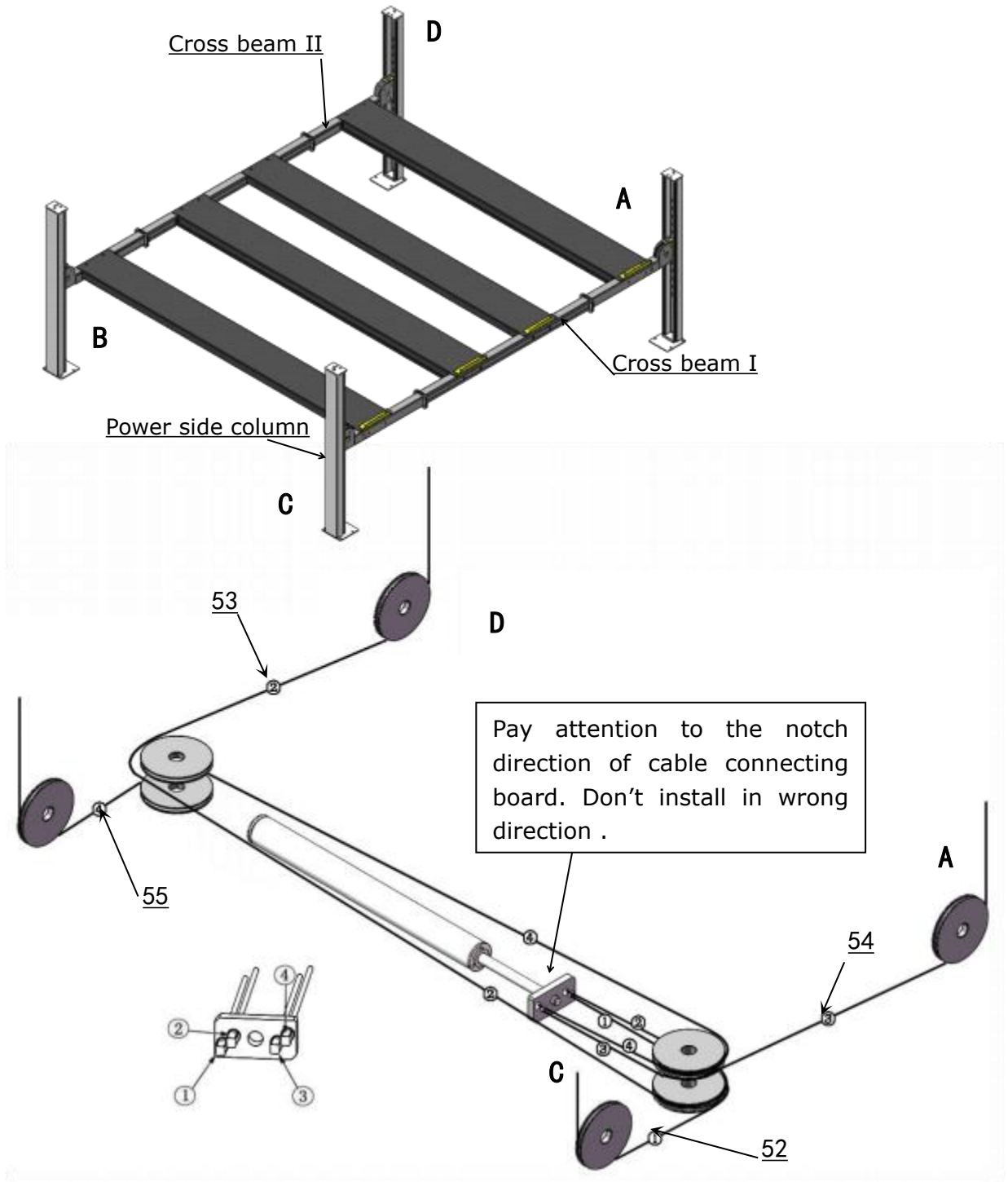
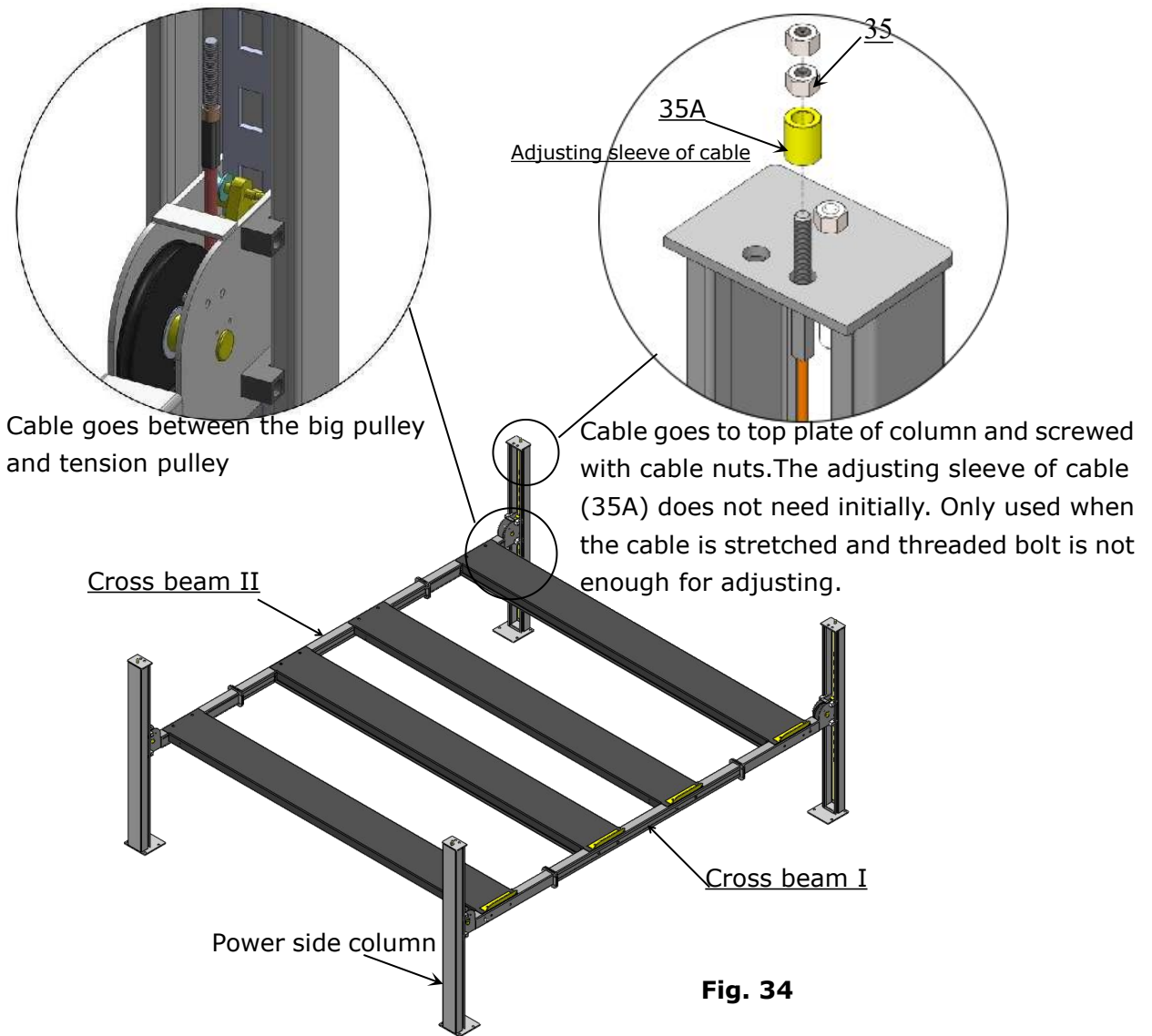

Fig. 33

Cable installation diagram

NO.	①	②	③	④
Cable				
409-DP Length (inc. cable fitting)	2940mm 115 3/4"	10960mm 431 1/2"	6790mm 267 5/16"	7120mm 280 5/16"
409-DPX Length (inc. cable fitting)	3274mm 128 29/32"	12019mm 473 3/16"	7142mm 281 3/16"	8155mm 321 1/16"

2. Pass The cables through the cross beam pulley and tension pulley, to top plate of columns and screw with cable nuts (**See Fig. 34**).



3. The sketched overview of cables finally installed under platform (**See Fig. 35, 36, 37**).

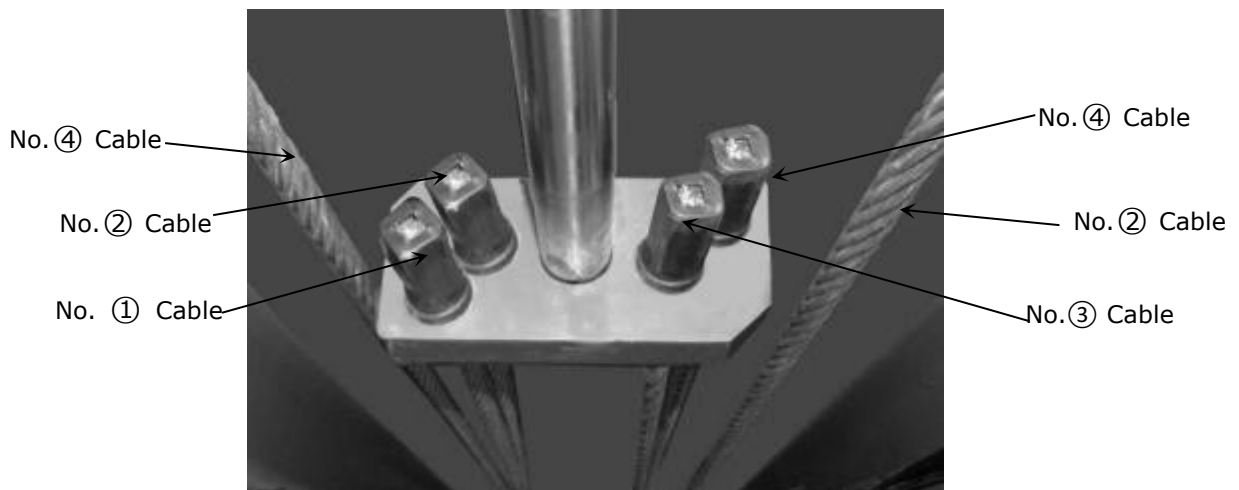

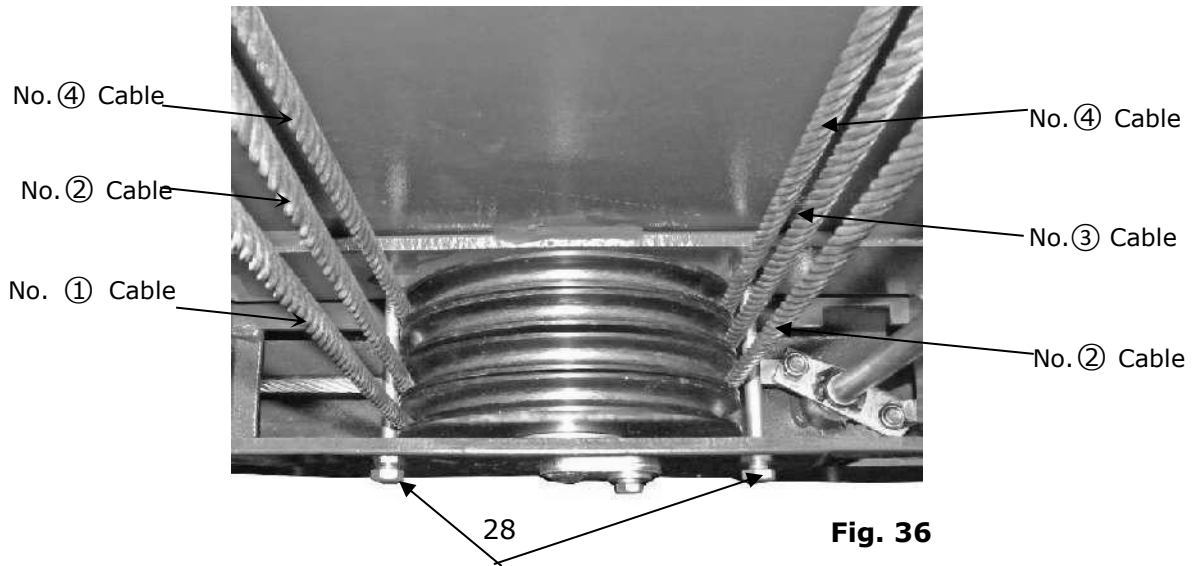

Fig. 36

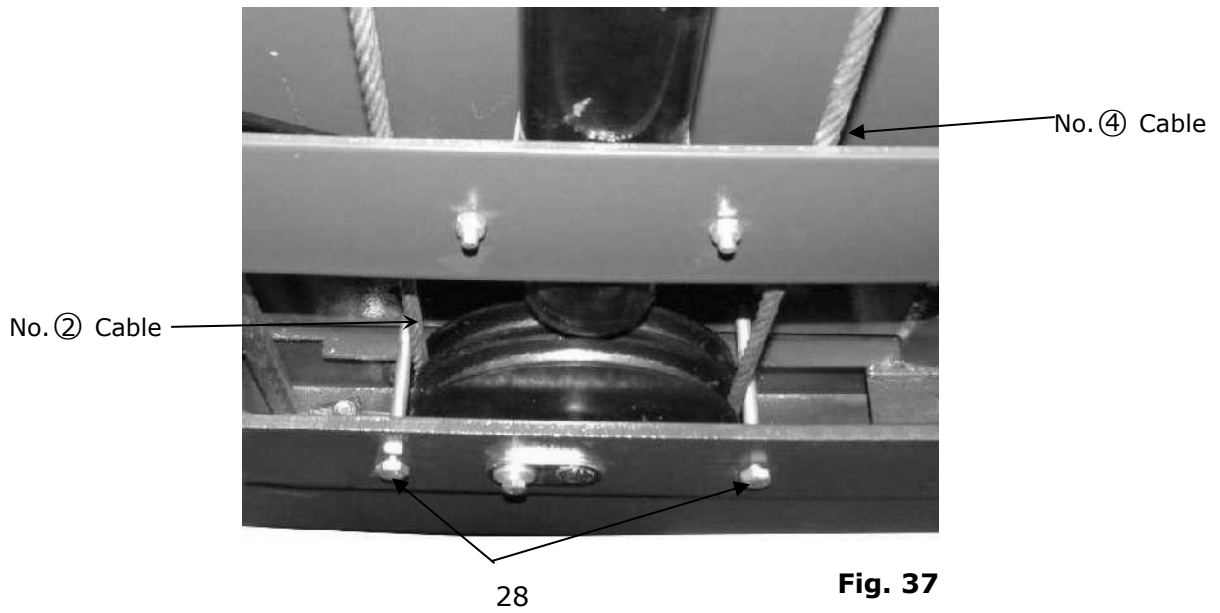

Fig. 37

4. Install tension spring and cross beam safety cover. **(See Fig. 38).**

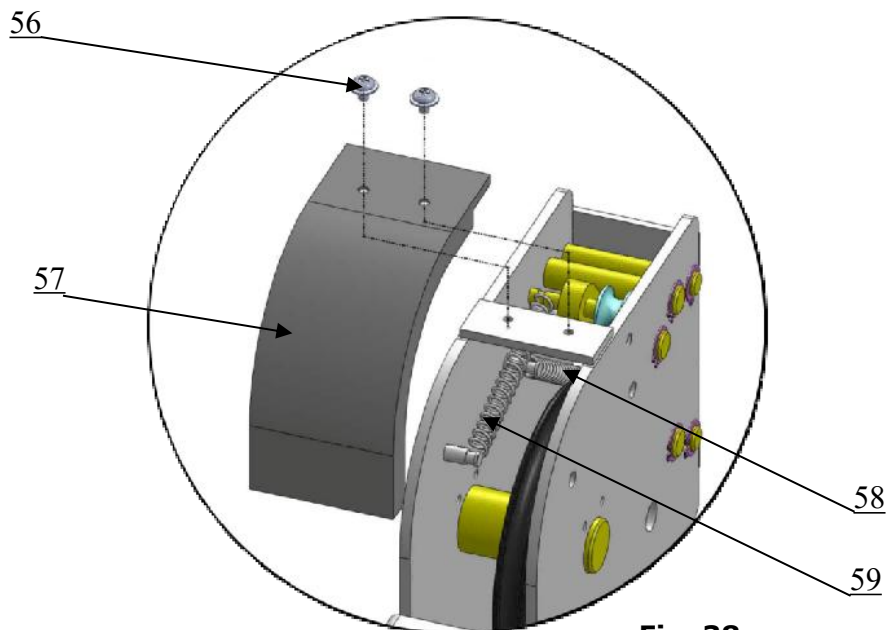

Fig. 38

M. Install power unit

Fixing the motor installing plate to the power side column. And install the power unit to the installing plate. See fig 39.

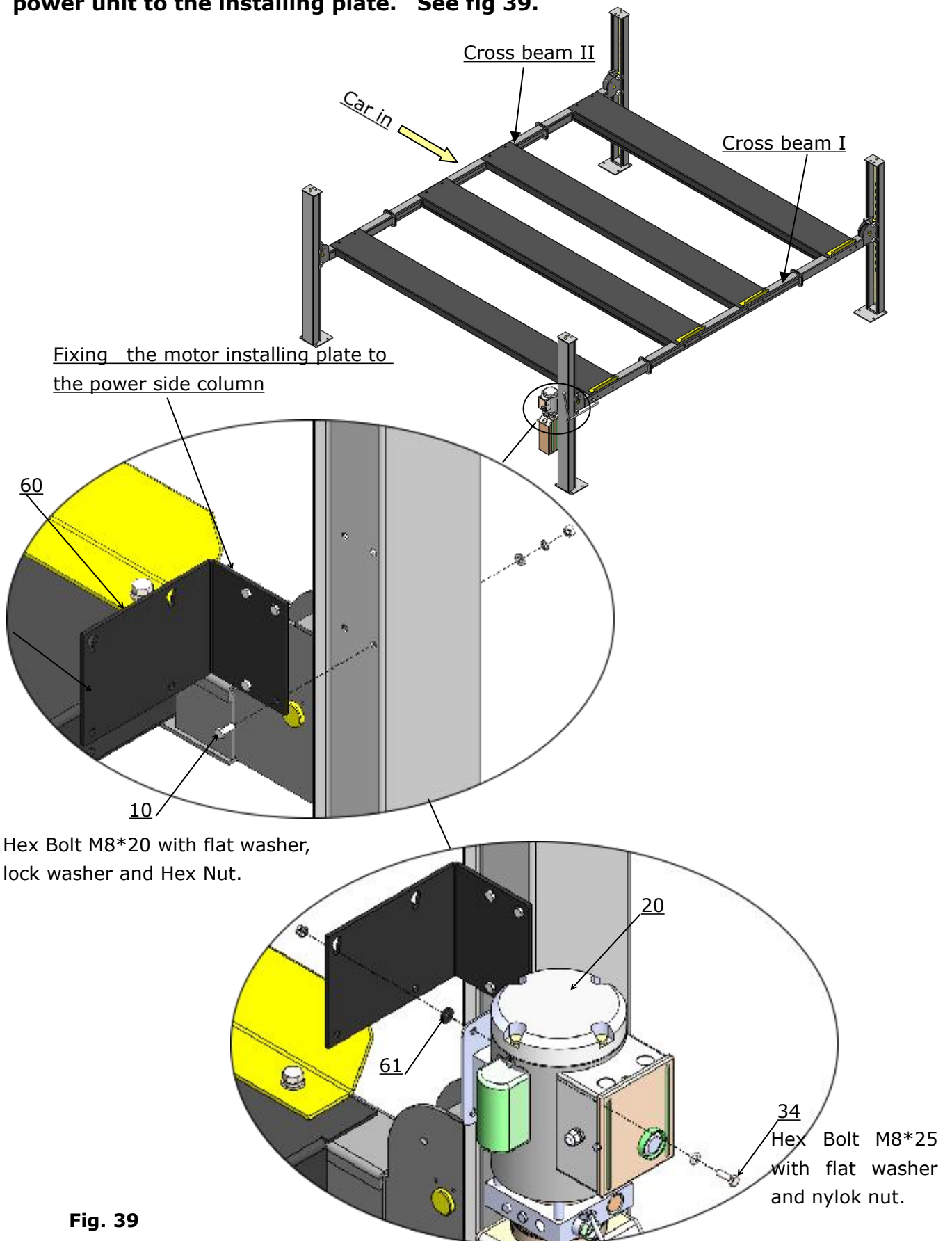
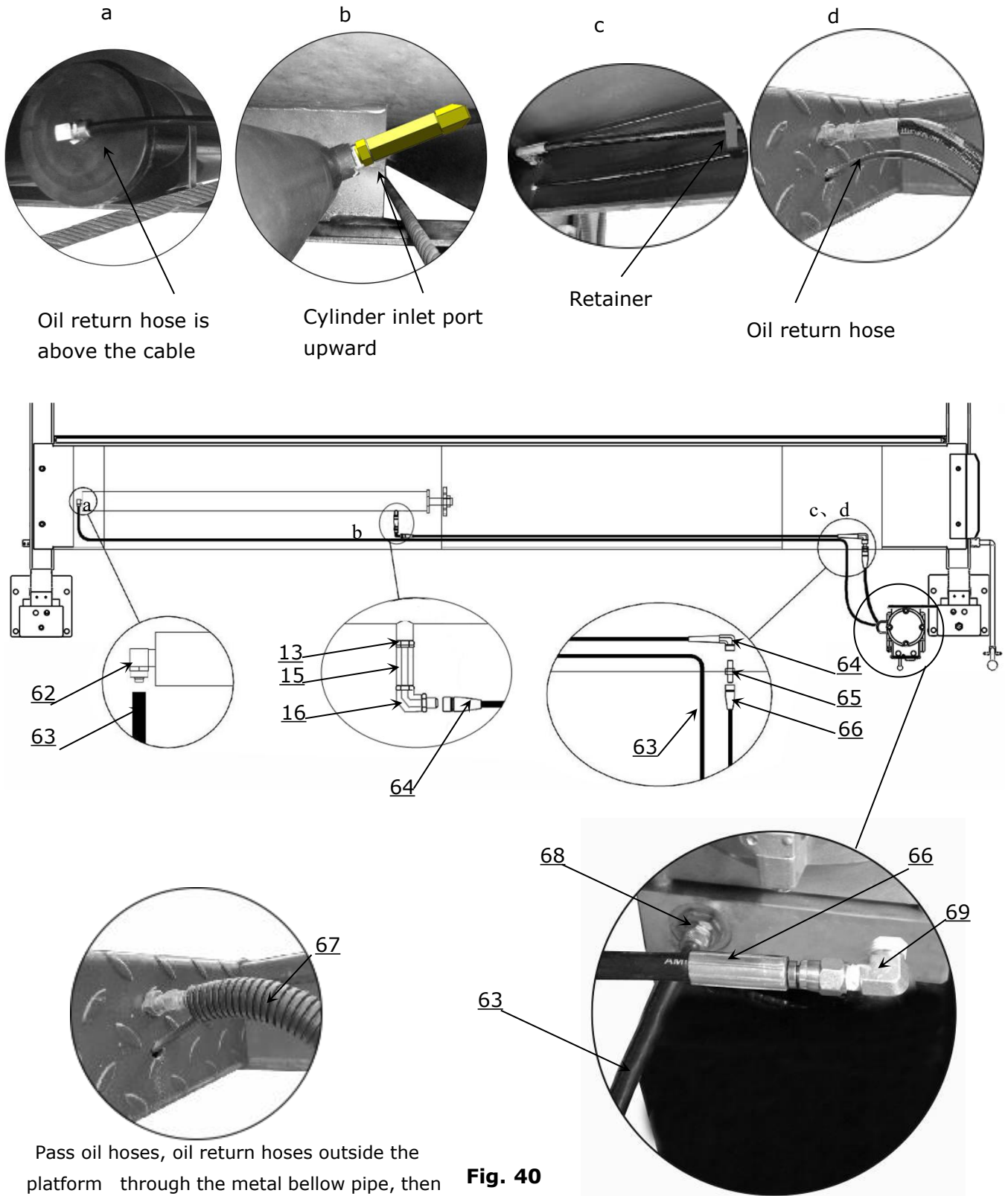

Fig. 39

N. Install Hydraulic System

1. For power unit install to the column at the side of cross beam **A** (See Fig. 40)

Note: Oil hoses connected to oil cylinder must be passed above the cable and cylinder inlet port should be upward a little to avoid the oil hose scratched by cable.



Pass oil hoses, oil return hoses outside the platform through the metal bellow pipe, then connect to the power unit

Fig. 40

O. Adjust columns plumbness, Install the anchor bolts.

1. Check the plumbness of columns with leveling instrument and adjusting with the shims.

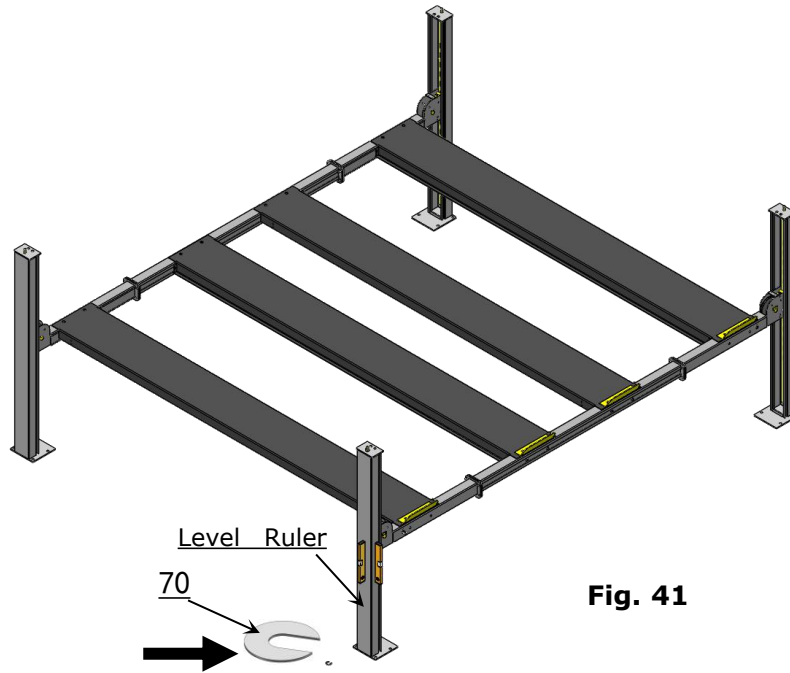

Fig. 41

2. Prepare the anchor bolts (See Fig. 42).

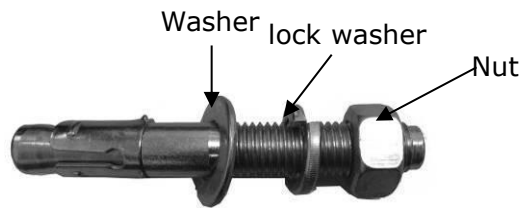

Fig. 42

3. Use the prescribed rotary hammer drill, drill all the anchor holes and install the anchor bolts and tighten all nuts. (See Fig. 43)

Note: The tightening torque for the anchor bolt is 150N.m ,Anchor bolts driven into the ground at least 90mm(3 1/2").

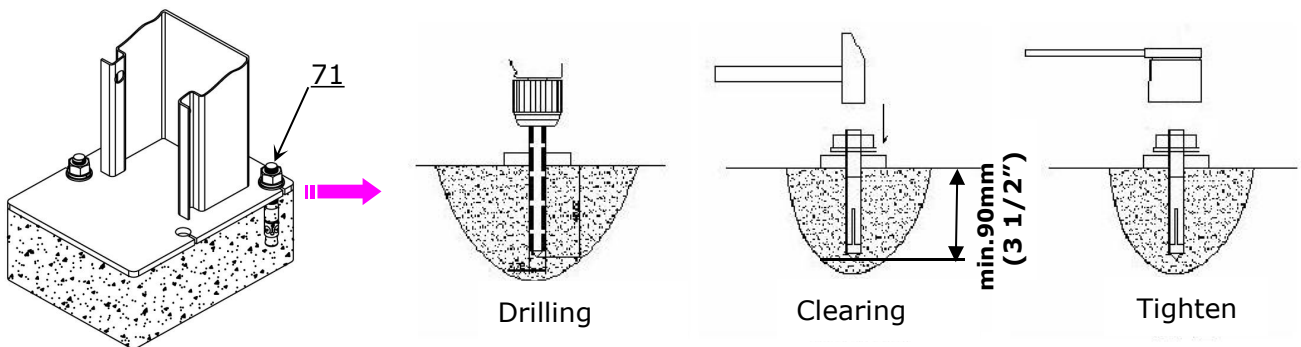
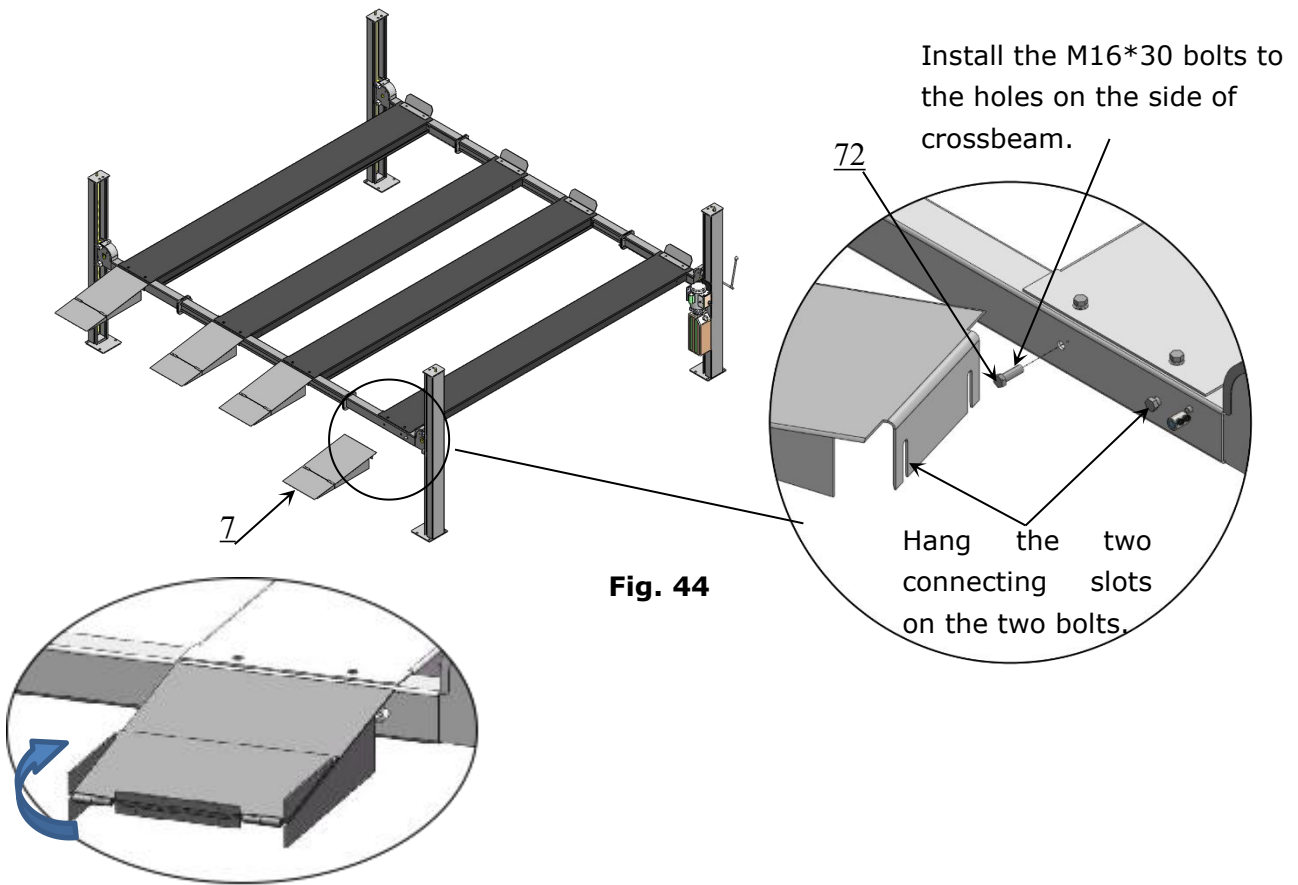

Fig. 43

P. Install foldable drive-in ramp assembly

Install the M16*30 bolts into the cross beam according to the below diagram, then hang the 4 units foldable drive-in ramps assy. on the bolts. See fig 44.



Fold up the front half of ramps after the car is parked well.

Exploded View of Foldable drive-in ramps assembly

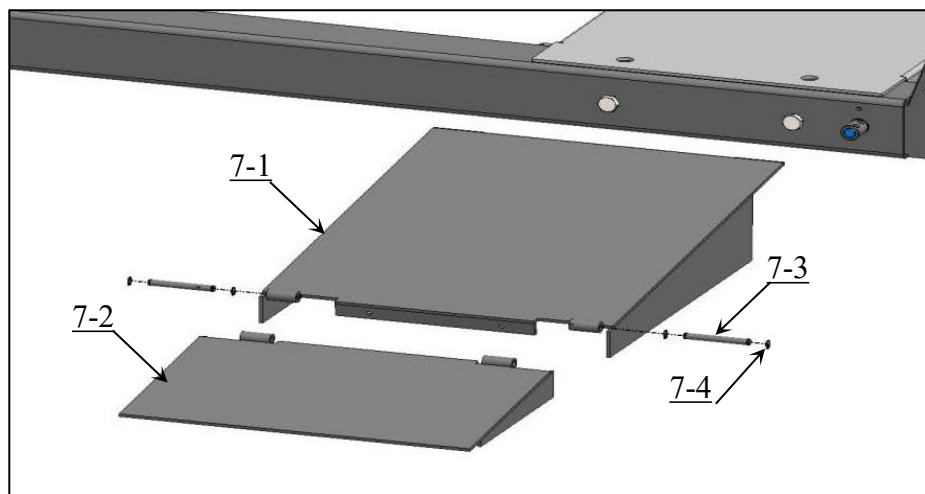
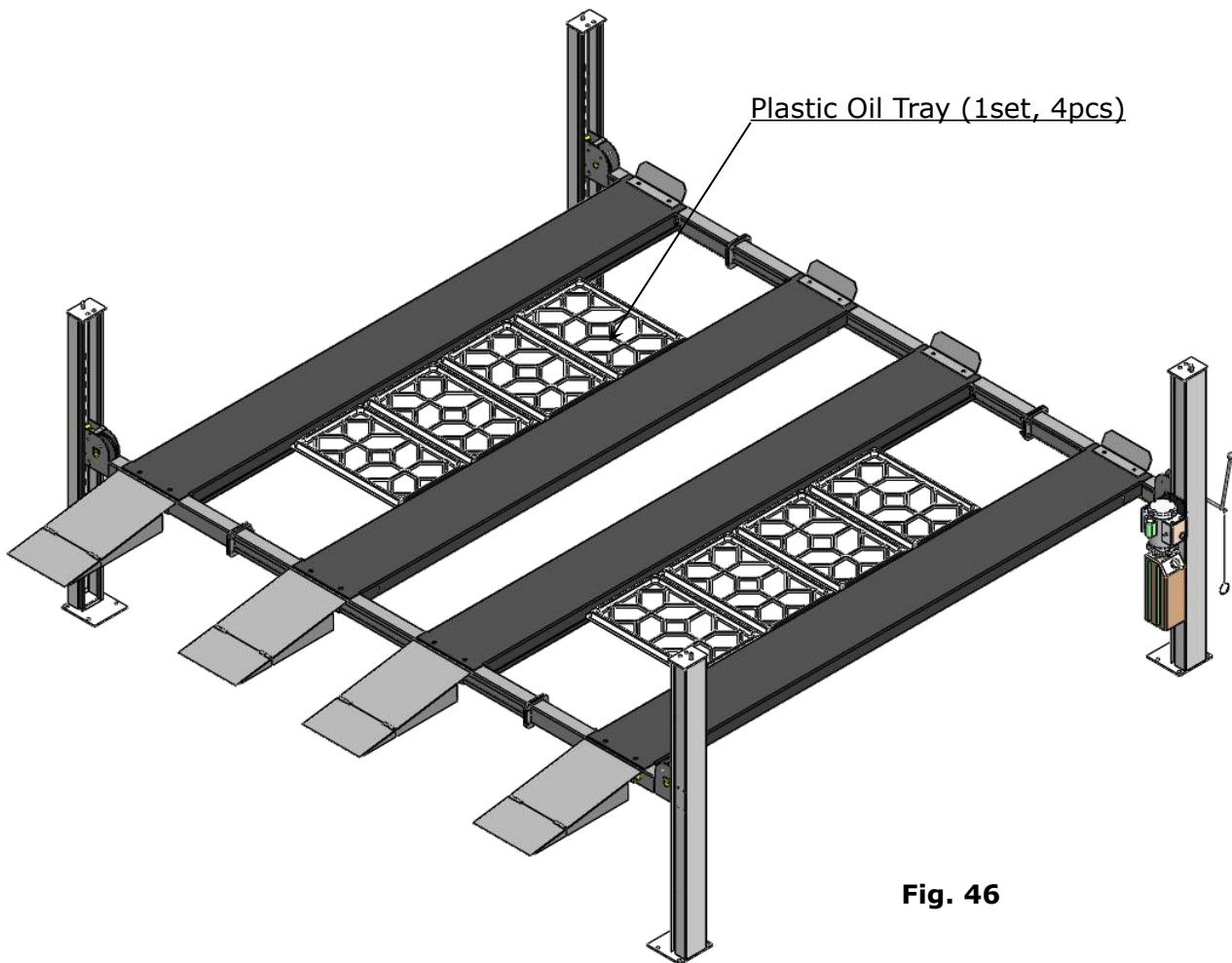

Fig. 45

Parts List of Foldable drive-in ramps assembly (1104533025C)

No.	Part Number	Description	Qty
7-1	1104233003A	Foldable drive-in ramps #1	2
7-2	1104233004A	Foldable drive-in ramps #2	2
7-3	1104543021	Connect Pin	4
7-4	10209010	φ10 Snap Ring	8

Q. Install optional plastic oil tray (Kits No.40806)



R. Install optional Storage Wave Panels (Kits No.40812)

Every lift can use 1 set or 2 sets

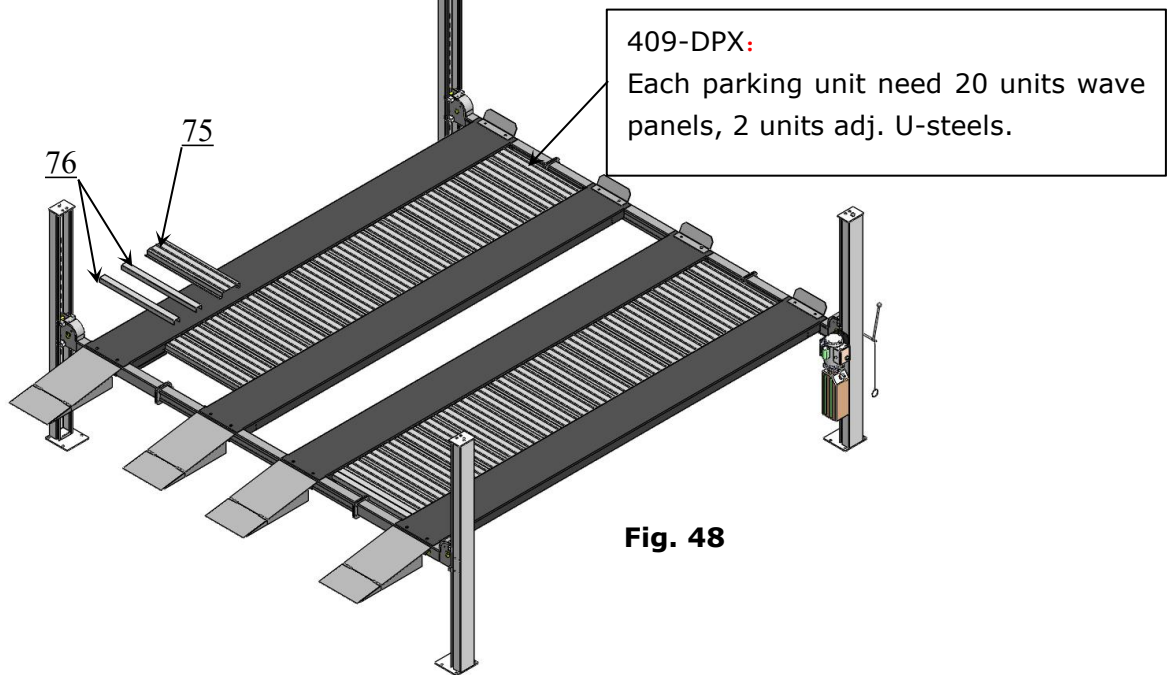
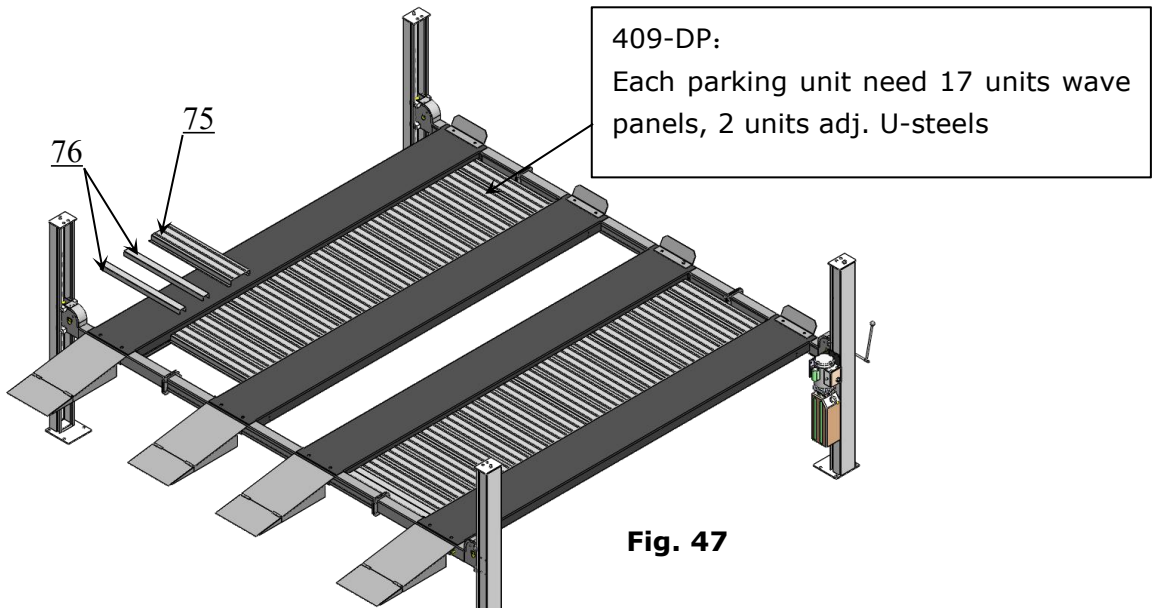

Parts List of Storage Wave Panels (Kits No. 40812)

No.	Part Number	Description	Qty
75	1004574008	Wave Panel	20
76	1104574002	Adj. U-Steel	2

S. Install Electrical System

Connect the power source according to the data plate of Motor.

Note: For the safety of operators, the power wiring must contact the floor well.

Single phase motor

Connect the two power supply wire (fire wire **L** and zero wire **N**) to terminals of AC contactor marked **L1, L3** respectively. Connect the earth wire to earth strip.

Note: if the local power are with 2 live wires, connect them to L1, L3 terminal of AC contactor respectively.

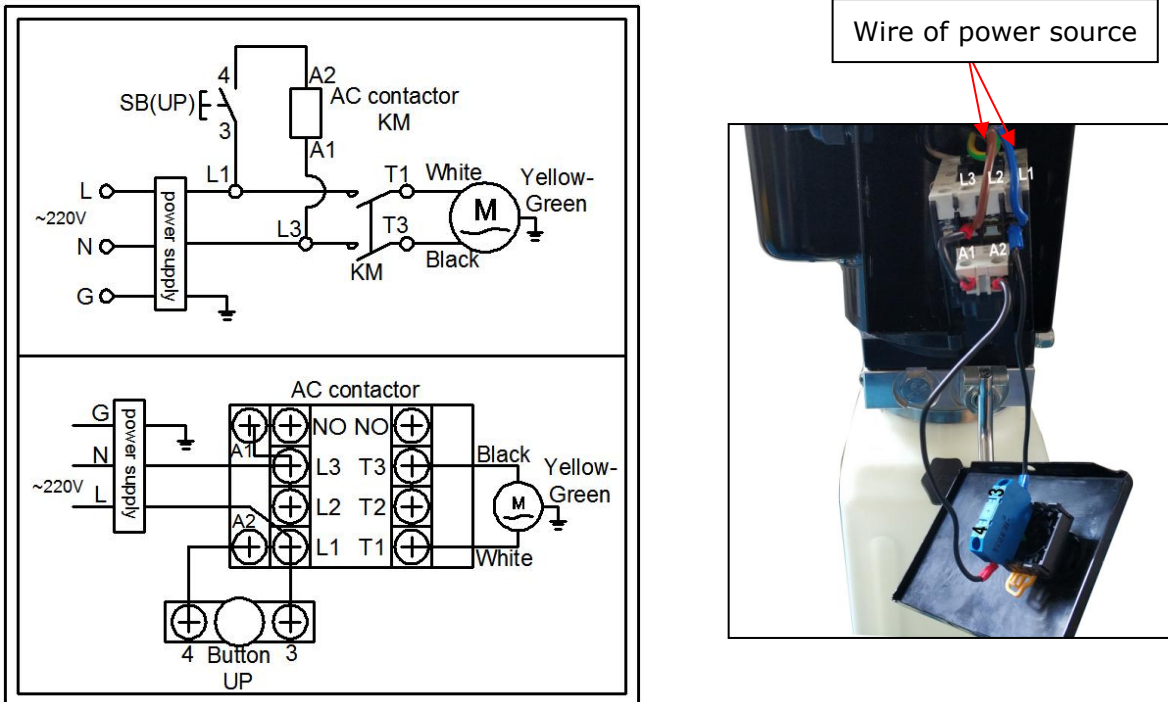

Fig. 49

⚠ DANGER

In case the cable is damaged or badly worn, DO NOT use the lift. Once the vehicle is lifted up without noticing cable damaged or worn, lower the vehicle to ground very carefully, and cut off the power immediately, then removed the damaged or worn cables.

IV. EXPLODED VIEW

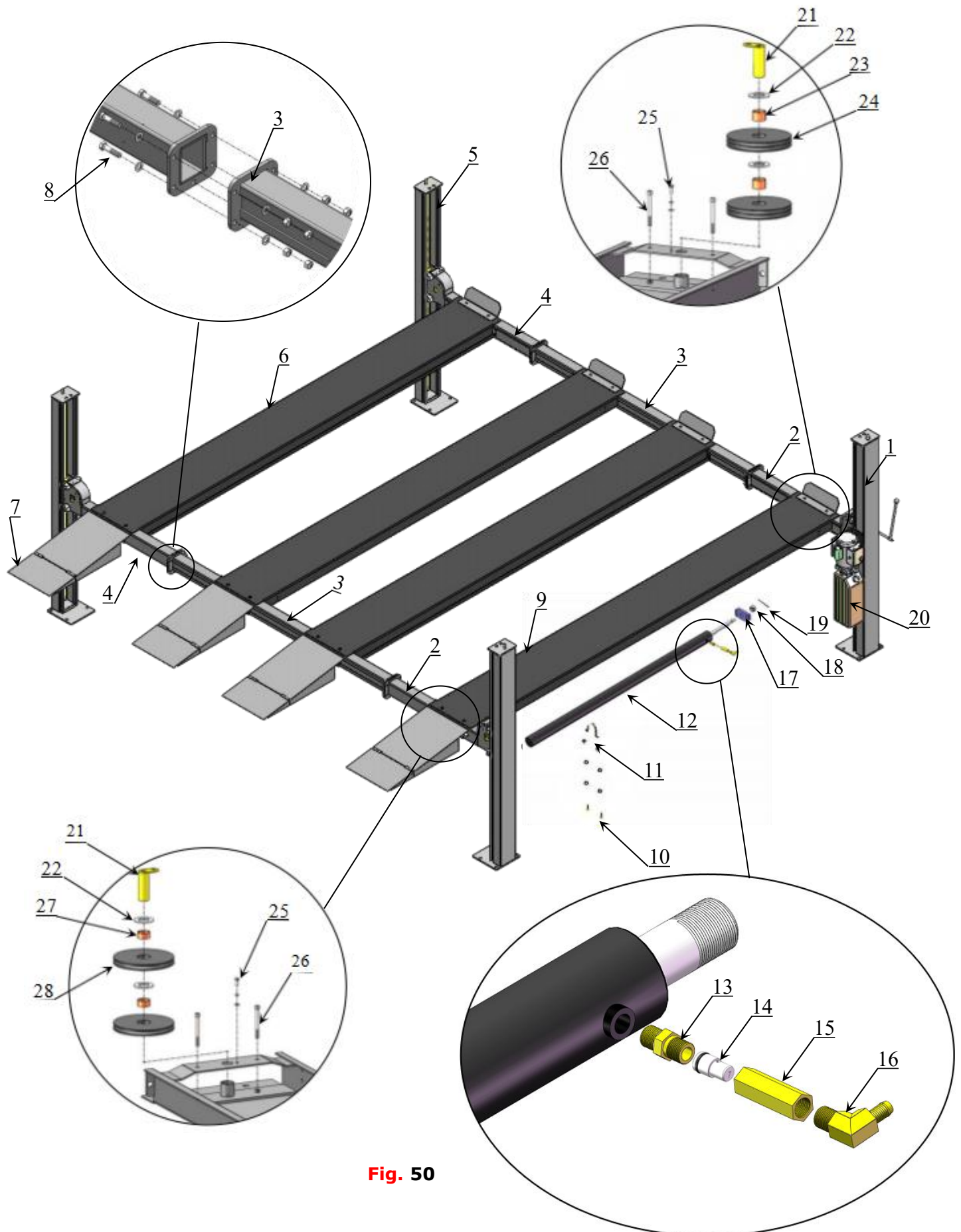

Fig. 50

PARTS LIST

No.	Part No.	Description	Quantity	
			409-DP	409-DPX
1	11410001-01	Power side column	1	0
	11410074-02		0	1
2	1104572012A	Cross beam connection B	2	2
3	1104572007A	Cross beam	2	2
4	1104572011A	Cross beam connection A	2	2
5	11410002-01	Off side column	3	0
	11410075-02		0	3
6	1104573001B	Off side platform	3	0
	1104583001B		0	3
7	1104533025C	Foldable drive-in ramps assy.	4	4
8	1004574010	Hex Bolt M14*50 (12.9GD, Half Threaded), with 2 flat washers, 2 hex nuts (12.9GD).	20	20
9	1104573001A	Power side platform	1	0
	1104583001A		0	1
10	1004574011	Hex Bolt M8*20 (incl. flat washer, lock wash and hex nut)	2	2
11	11410090	Cylinder retaining ring	1	1
12	10410081	Cylinder	1	0
	10410070-02		0	1
13	11420243	Transition fitting.	1	1
14	10209119	Pressure compensated flow restrictor	1	1
15	10420245	Switching fitting	1	1
16	10201020	90° Fitting	1	1
17	1104573005	Cable connecting board.	1	1
18	10420014	Hex bolt M27	1	1
19	10201005	Cotter pin ϕ 4*50	1	1
20	81513016	Manual power unit	1	1
	071109		1	1
21	1104533012A	Pulley shaft weldment	2	2
22	10420023A	Flat Washer ϕ 36* ϕ 65*3	4	4
23	10530042	Bronze bush for Pulley ϕ 41.3* ϕ 35.1*28	2	2
24	1104533023	Pulley (dual grooves)	2	2
25	1004574012	Hex Bolt M8*20 (incl. ϕ 8* ϕ 25*3 flat washer, lock washer.)	2	2
26	10650502	Socket bolt M10*100 (half threaded)	4	4
27	10420132A	Bronze bush for Pulley ϕ 41.3* ϕ 35.1*20	2	2
28	11420024B	Pulley	2	2
29	1104572006A	Safety device coupling bar	2	2
30	1104572014	Safety device connecting bar	4	4
31	10217002	Hex nut M8	4	4
32	10209034	ϕ 8 Lock washer	4	4
33	1004574013	Hex bolt M8*20 (incl. flat Washer, nylok nut)	2	2
34	1004574014	Hex bolt M8*25 (incl. flat Washer, nylok nut)	6	6

No.	Part No.	Description	Quantity	
			409-DP	409-DPX
35	10420175A	Hex nut M20	16	16
35A	1104571001	Adjusting sleeve of cable ϕ 28*30	4	4
36	11410022	Safety ladder	4	0
	11410073-01		0	4
37	1004574015	Hex bolt M16*30 (incl. lock washer, flat washer)	8	8
38	1004574016	Hex bolt M16*35 (incl.lock washer, flat washer)	8	8
39	11410015-1	Tire Stop	4	4
40	1004574017	Hex bolt M12*20(8.8GD) (incl. lock washer, flat washer)	8	8
41	1004574018	Socket bolt M8*40 (incl. flat Washer, nylok nut)	16	16
42	10410016A	Slider block 81*38*38	16	16
43	11410024	Coupling sleeve	1	1
44	11410023	Safety device connecting rod ϕ 19*2060mm	2	0
	11410069-01	Safety device connecting rod ϕ 19*2410mm	0	2
45	1004574019	Socket Bolt M8*35, incl. lock washer	4	4
46	11410026	Release handle.	1	1
47	10217005	M10 Plastic ball.	1	1
48	11410100	Extended release handle	1	1
49	10209056	Nylok Nut M10	1	1
50	1004554006	Pull rope	0	1
51	1004574020	Socket Bolt M8*25 (incl. lock washer)	2	2
52	10410019	No. ① cable assy. ϕ 9.52 x 2940mm (3/8" x 115 3/4")	1	0
	1004583003	No.① cable assy. ϕ 9.52*3274mm (3/8" x 128 29/32")	0	1
53	1004573004	No.② cable assy. ϕ 9.52*10960mm (3/8" x 431 1/2")	1	0
	1004583004	No.② cable assy. ϕ 9.52*12019mm (3/8" x 473 3/16")	0	1
54	1004573002	No.③ cable assy. ϕ 9.52*6790mm (3/8" x 267 5/16")	1	0
	1004583002	No.③ cable assy. ϕ 9.52*7142mm (3/8" x 281 3/16")	0	1
55	10410021	No.④ cable assy. ϕ 9.52*7120mm (3/8" x 280 5/16")	1	0
	1004583001	No.④ cable assy. ϕ 9.52*8155mm (3/8" x 321 1/16")	0	1
56	10209145A	Round head bolt M6*12 with washer	8	8
57	10410029	Cross beam safety cover	4	4
58	10410146	Tension spring ϕ 14*2.0*75	4	4
59	10420033	Tension spring ϕ 14*1.8*100	4	4
60	1104551003	Motor installing plate	1	1
61	10209004	Rubber ring ϕ 8* ϕ 20*3	4	4
62	10420166	90° oil return 6*4 screw fitting 1/4" male	1	1

No.	Part No.	Description	Quantity	
			409-DP	409-DPX
63	10410028	Oil return hose assy. L=5500mm(216 17/32")	1	0
	10410072-01	Oil return hose assy. L=6200mm(244 3/32")	0	1
64	1004573004	Oil Hose assy. 1/4"x1910mm(75 3/16")	1	0
	10410137-01	Oil Hose assy. 1/4"x2250mm(88 19/32")	0	1
65	10420120	Extended straight fitting with lock nut	1	1
66	1004533007	Oil hose assy. 1/4"x1420mm (55 29/32")	1	1
67	1004533008	Metal bellows pipe φ20*1*1400mm (L=55 1/8")	1	1
68	10420095	Oil return 6*4 straight screw fitting 3/8"male	1	1
69	10209060	90° fitting for power unit	1	1
70	10201090	Shim 2mm(5/64")	20	20
	10620065	Shim 1mm(3/64")	20	20
71	10209059	Anchor bolts 3/4" x 5-1/2"	16	16
72	10410013	Hex Bolt M16*30	8	8
73	1004574009	Parts Box	1	0
	1004584004		0	1
74	1104572003A	Rotation device	2	2

4.1 CYLINDERS EXPLODED VIEW

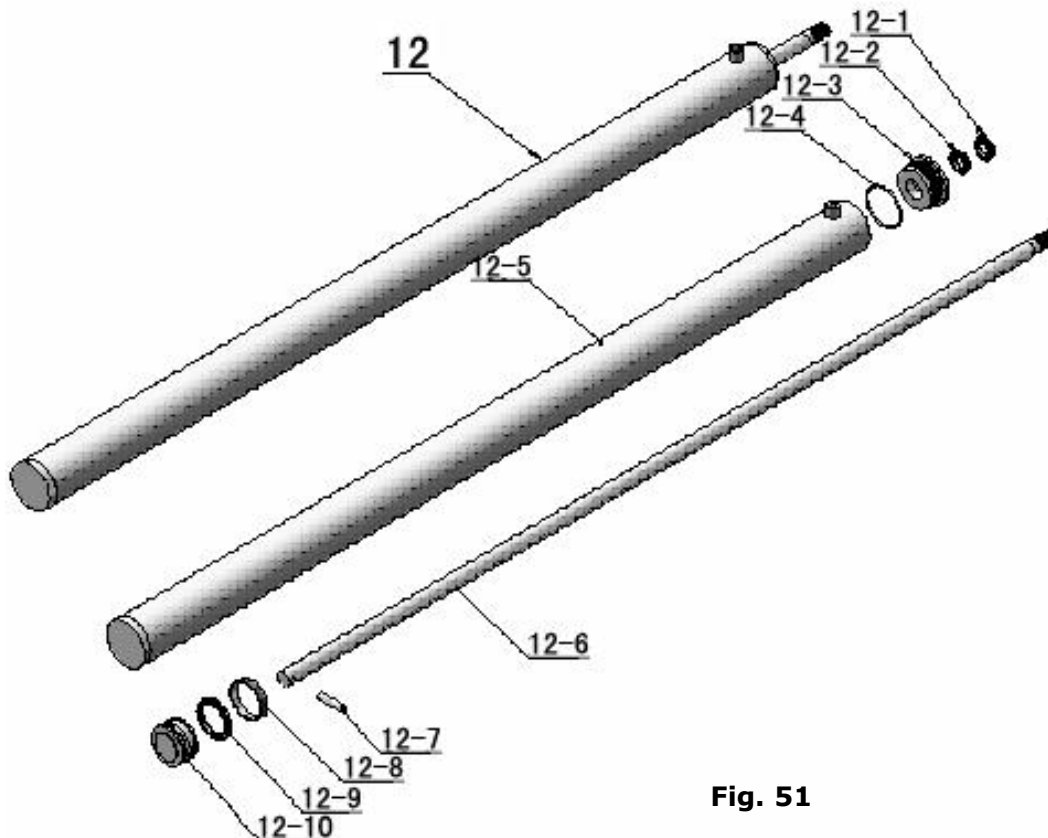

Fig. 51

Parts List

Item	Part#	Description	Quantity	
			409-DP	409-DPX
12-1	10420059	Dust Ring	1	1
12-2	10420060	Y- Ring IDI	1	1
12-3	11410082	Head Cap	1	1
12-4	10410083	O- Ring	1	1
12-5	11410084	Bore Weldment	1	0
	11410078-02		0	1
12-6	11420064	Piston Rod	1	0
	11410079-02		0	1
12-7	11420065	Pin	1	1
12-8	10420066	Support Ring	1	1
12-9	10420067	Y- Ring OSI	1	1
12-10	11420068	Piston	1	1

Illustration of hydraulic valve for hydraulic power unit

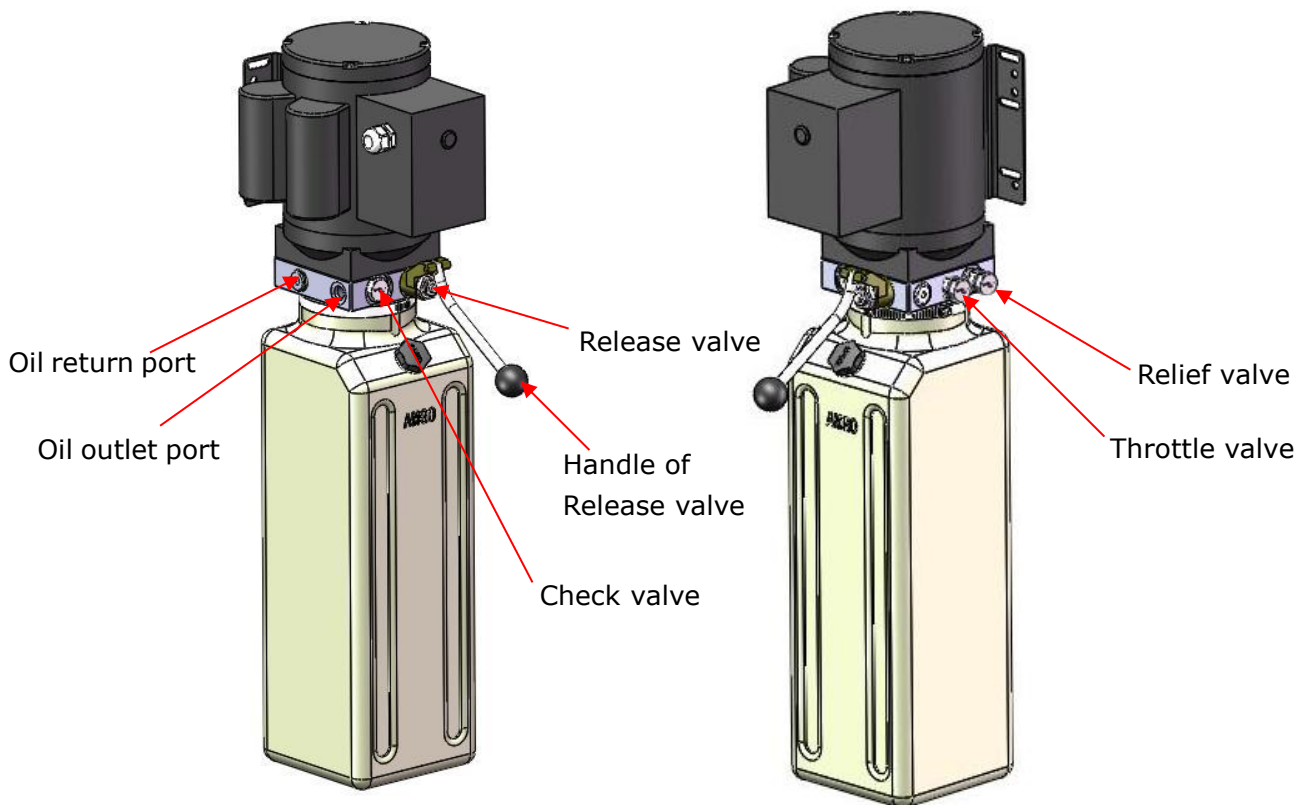

Fig.52

V. TEST RUN

1. Fill the oil tank with around 11L hydraulic oil (in order to ensure the service life of the hydraulic system and ensure the best condition of the equipment, please fill in #46 high-quality anti-wear hydraulic oil).
2. Press the power unit button, until the four cables are tightened. Check the coordination between the cables and the pulleys, the cables **SHALL NOT** cross or fall out of the pulley.
3. Press the power unit release handle to lock the cross beam on the safety ladder. Adjust the safety ladder nuts to make sure the platforms at same level. Then tighten both the top and bottom nuts of safety ladder.
4. Balance the tension of cables by adjusting the cable nuts. It is a must to run several cycles up/down of the lift when performing synchronization operation. Make sure all four safety locks can be locked/released at the same time, then tightened all the cable nuts.
5. Make sure the cross beam slide blocks and columns are clearance fit, that the slider blocks can slide smoothly with the column. **DO NOT** tighten the slider blocks.
6. After all above adjustments finished, take the loading test. Firstly low-level load test are taken several times to check the synchronization of operation and all safety locks. If they are no other abnormal phenomena, then take the full cycle load tests several times, otherwise repeat the above adjustments.

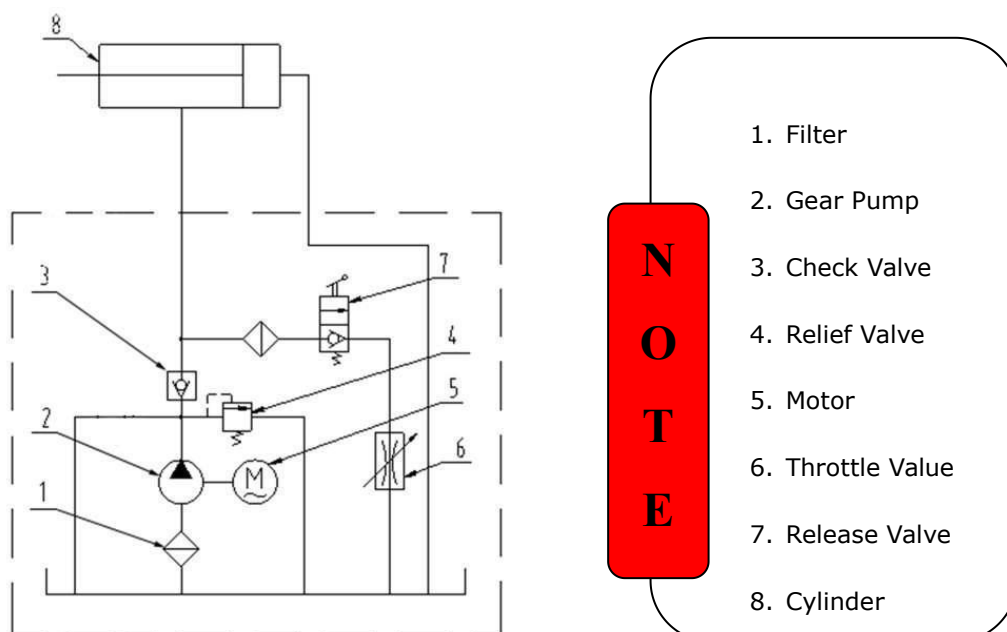

Fig. 53
Hydraulic Schematic Diagram

VI. OPERATION INSTRUCTIONS

Please read the safety tips carefully before operating the lift

To lift vehicle

1. Keep clean of site near the lift;
2. Drive in the vehicles on platforms and apply the parking brake.
3. Power on, push the power unit UP button, lift the vehicles to the working position.

Note: Make sure the vehicles are in steady safe status.

4. Press the power unit release handle, the lift goes down and be locked. Check and make sure the lift is locked at the same level locks .
5. Fold up the front half of drive-in ramps.

WARNING

It is unsafe to work under the lift without locking at the safety device after it has been lifted up, which may causes vehicle fall, damage, lift damage, human injury or even death.

To lower vehicle

1. Clear obstructions around and under the lift and keep people away from the lift.
2. Push power unit **UP** button to raise the lift 3-5 seconds, then the safety lock is out of lock status. Pull the release handle, make sure the safety lock released, press the power unit release handle, the lift will start to lower.
3. Lower the lift to the lowest position, unfold the front half of drive-in ramps, and drive away the vehicles
4. Turn off the power.

VII. MAINTENANCE SCHEDULE

Monthly:

1. Lubricate cables.
2. Make visual inspection of cables for possible wear or damage.
3. Make visual inspection of hydraulic hoses for possible wear or leakage.
4. Lubricate all rollers, pins and safety devices with 90WT gear oil.

Every six months:

1. Make a visual inspection of all moving parts for possible wear, interference or damage.
2. Check and adjust as necessary, cable tension to ensure synchronization.
3. Check columns for plumbness.

Oil cylinder maintenance:

In order to extend the service life of the oil cylinder, please operate according to the following requirements.

1. Recommend to use N46 anti-wear hydraulic oil.
2. The hydraulic oil of the lifts should be replaced regularly during using. Replace the hydraulic oil 3 months after the first installation. Replace the hydraulic oil once a year afterwards.
3. Make at least one full trip raising and lowering per day. For exhausting the air from the system, which could effectively avoid the corrosion of the cylinder and damage to the seals caused by presence of air or water in the system.
4. Protect the outer surface of the oil cylinder's piston rod from bumping and scratching, and timely clean up the debris on the oil cylinder dust-ring and the piston rod.

DANGER

Make sure the lift is completed disconnected from the power source before maintenance. If there is any external electrical lock/shutdown device, make sure to implement them before maintenance. The contact with high voltage/current, may cause injury or even death.

VIII. TROUBLE SHOOTING

TROUBLE	CAUSE	REMEDY
Motor does not run	<ol style="list-style-type: none"> 1. Start Button does not work 2. Wires in poor connecting 3. Motor burned out 4. AC contactor burned out 	<ol style="list-style-type: none"> 1. Replace start button 2. Repair wiring connections 3. Repair or replace motor 4. Replace AC contactor
Motor runs but the lift is not raised	<ol style="list-style-type: none"> 1. Gear pump in damage 2. Release valve in damage 3. Relief valve or check valve in damage 4. Insufficient hydraulic oil 	<ol style="list-style-type: none"> 1. Repair or replace 2. Repair or replace 3. Repair or replace 4. Fill in hydraulic oil
Lift falls automatically after rising	<ol style="list-style-type: none"> 1. Release valve failure 2. Relief valve or check valve failure 3. Cylinder or fittings leakage 	<ol style="list-style-type: none"> 1. Repair or replace 2. Repair or replace 3. Replace oil seal kit or fittings
Lift raises slowly	<ol style="list-style-type: none"> 1. Oil line blockage 2. Low voltage 3. Hydraulic Oil mixed with air 4. Gear pump leakage 5. Overload lifting 	<ol style="list-style-type: none"> 1. Clean up the oil line 2. Check electrical system 3. Fill in hydraulic oil 4. Replace gear pump 5. Check load
Lift cannot lower	<ol style="list-style-type: none"> 1. Safety devices are not released 2. Release valve in damage 	<ol style="list-style-type: none"> 1. Release the safety devices 2. Repair or replace

⚠️ WARNING A lift would be dangerous if operated by inexperienced or distracted operators. Operators should be fully aware that lifting a vehicle is a potentially life-threatening operation, especially if ignoring the mandatory safety precautions.

IX. CAR LIFT SAFETY TIPS

Put this safety tips in a place where you can always alert the operator. Please reference to the lift manufacturer's manual for specific information about the lift.

1. Check the lift daily. If the machine breaks down or has damaged parts, do not operate, and use original equipment parts to repair.
2. **Do not** overload . The rated weight of the manufacturer design is indicated on the label of the lift.
3. Position control of the vehicle and operation of the lift can only be done by a trained and authorized person.
4. **Do not** lift a car with occupants inside. Keep the customers or bystanders away from the lift.
5. Keep the area around the lift free of obstacles, lubricating oil, grease, garbage and other debris for a long time.
6. Carefully drive the vehicle onto the lift and lifting up to the required height for operation. **Noted:** lift it high enough if you are working underneath, and make sure the safety devices are locked.
7. **Noted:** removing(install) parts from(to) a vehicle would cause a sudden shift of gravity which may result in instability of the vehicle. Please refer to the vehicle manufacturer's service manual as a recommended procedure if you need remove/install parts from(to) the vehicle
8. Before lowering the lift , make sure all obstacles underneath, include tool tray, tool rack etc., are all removed.

X. LIFT DISPOSAL

When the car lift cannot meet the requirements for normal use and needs to be disposed, it should follow local laws and regulations.



PEAK CORPORATION

No. 3 Luomu Road, Shishan Town, Nanhai District, Foshan(528225), Guangdong, China

Tel: 86-757-81102815 81102805

Fax: 86-757-81102809

Email: peak@peaklift.cn <http://www.peaklift.cn>

Manual Part No.: 72149101

Revision Date: **2023/07**