



**STAR  LINER™**

**HD FRAME MACHINES**

**800.445.8244**

# HD SIZES

- 27'
- 40'
- 50'
- 60'
- Custom Size



# FLOOR LAYOUT

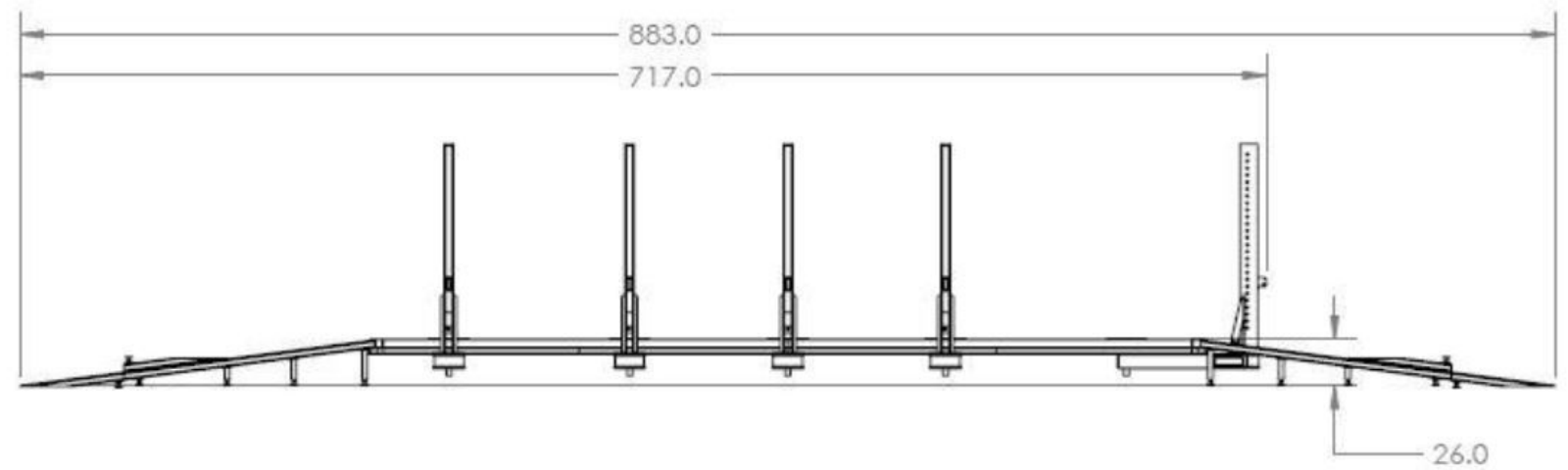

# FEATURES

- Drive On/Off - Above Ground or Pit Design
- 102" Wide Bed
- 32" Wide 1/2" Thick Tread Ways
- Plated Top and Bottom
- 26" Working Height
- Hydraulic Towers (10' Tall): 25' (6), 40' (10), 50' (12), 60' (14) - 25 Ton
- Machines is Plumbed for Electric Hydraulics
- Two Electric Pumps with Remotes
- 16' Long 1/2" or 5/8" Tower Chains with Slip Hooks
- 2 (Standard) or 4 (Drive On/Drive Off Option) Portable Ramps with Fork Lift Pockets
- 360 Degree Pulling Radius



# DESIGN

Our HD Frame Machines are designed to straighten the frames and correct the cabs on semi trucks, tractors, trailers, transit buses, cube vans, and medium duty trucks.

Users are able to pull a full 25 tons without the worry of flexing the body of the frame machine, or damaging the bearings. This is because the unique design of our shaft and bushing towers, which is much different than our competition.

Each tower is equipped with (1) ton 14" stroke ram, (1) 26', 1/2", or 5/8" pull chain, and (1) tower on/off valve.

The frame machine is 11" thick to ensure extreme bracing and support throughout. The 1/2" thick table has chain holding slots every twelve inches throughout the complete inside and outside of the bed. It also has more holes throughout to support more down pulls and holding.

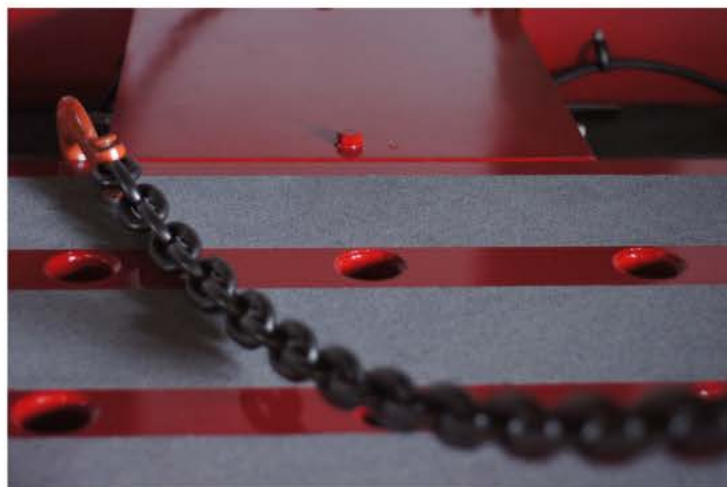

# 25 TON TOWERS



- 25 Ton 14" Stroke SPX Rams
- Shut Off Valves on Each Tower
  - 1/2" Thick Tower Uprights
  - 10' Tall Towers
  - Round Pivot Bottom
  - HD Leverage Arm
- 1/2" or 5/8" Pull Chains



# TOWER BASE PIVOT

- Each Tower Pivots on Solid Shaft and Bushing



- Greasable
- Low Maintenance
- Long Lasting
- No Stress on Main Deck
- Laminated Main Tower Tubes



# SOLID HD BED

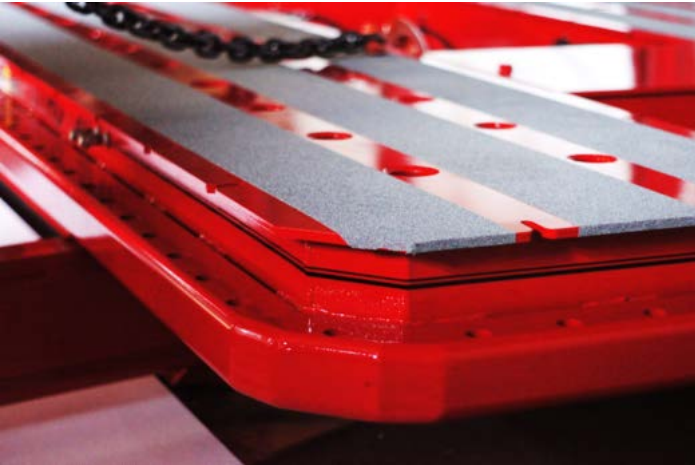

- Solid 1 / 2" Laser Cut Top
  - Solid 1 / 4" Lower skin
- Sidewall - 10" HD Channel
- 3" Welded in Anchor Tubes
  - 102" Wide
- Chain Anchor Slots Every 12"
  - Bed Thickness - 11"





# ELECTRIC HYDRAULICS

- (2) SPX 1 / 2 HP Electric Pump
- 110/ 115v (20AMP) Single Phase
  - 10,000 PSI
  - Handheld Remote
  - USA Made



# OPTIONAL TOOL BOARDS

Tool Package A-2



Tool Package A-1

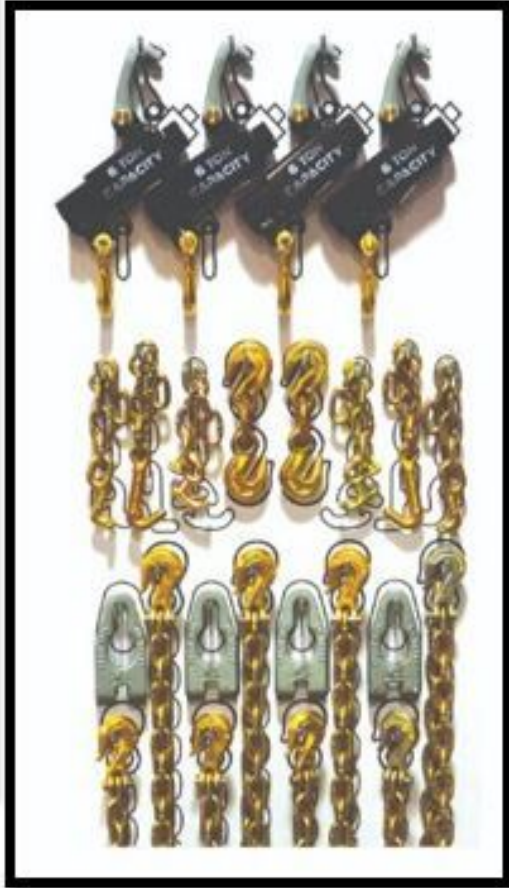

T4 Truck Tie Down

# ADDITIONAL ACCESSORIES



Heavy Duty Flange Tool



Half Moon Chain Rest



Pulling Chain



Small Flange Press



Heavy Duty Rail Puller



Large Flange Tool

# ADDITIONAL ACCESSORIES



HD Floating Crossmember



Manual Jack Stand



Truck Guide Stand W/ Wheels



Hydraulic Jack Stand



HD "C" Frame Hooks



Down Pull Attachment

# ADDITIONAL ACCESSORIES



Mobil Clamp Cart

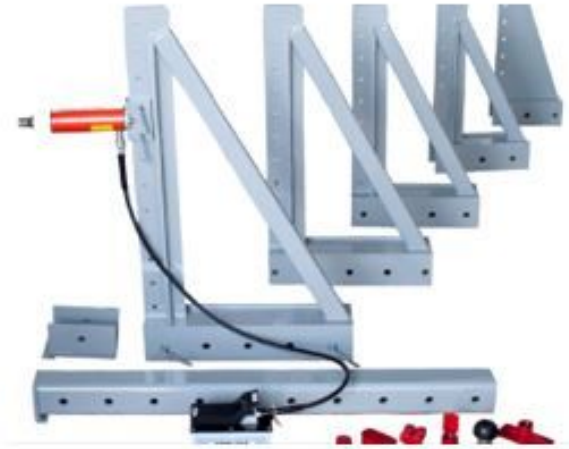

Multi Adapter Push Assembly



Tram and Gauge Set

# COMPUTERIZED MEASURING

## AUTO-VISION



**Measures in Real Time**

**Data Mode** with Mitchell Data

**Compare Mode:** Compares undamaged side to repair damaged side on vehicles where data is not available

**Point to Point:** Measure 5 Tram Readings at once

**Wheel Alignment:** Camber, Caster, Toe, Total Toe, Thrust Angle and Bent Suspension parts